



PEDALS - REMOVE / INSTALL

Scenario: Which way do I to turn to loosen and tighten pedals into crank arms?

TOOLS and SUPPLIES

- Pedal Wrench (15mm)
- 6mm allen wrench (some pedal models)
- 8mm allen wrench (some pedal models)
- Grease for threads



Pedal threads are different from left and right sides. The right drive side pedal has a right-hand thread (removes counterclockwise, installs clockwise). The left non-drive side pedal has a left-hand thread (removes clockwise, installs counterclockwise). Many pedals are stamped "L" and "R" for left and right.

Popular mythology has it that the Wright Brothers (airplane inventors) originated left handed pedal threads to keep pedals from unscrewing while riding. It is a good practice to screw pedals in tightly after final fit adjustments have been made. Pedal threads - like most component threads on a bicycle should be lubricated lightly with grease.

Left side notch found on many pedal brands.

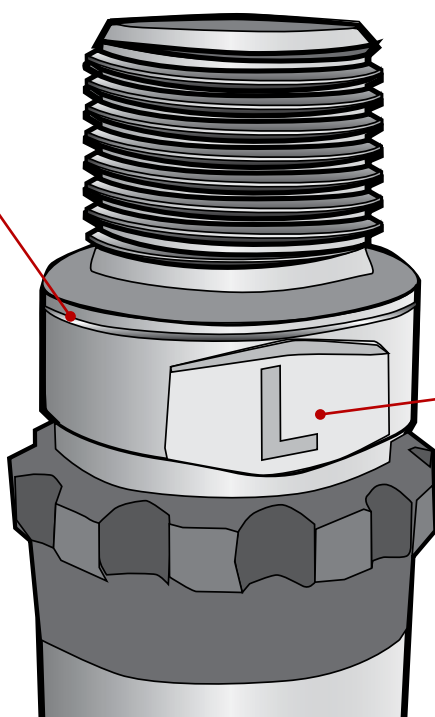

Most pedals have an indication of which side they attach.

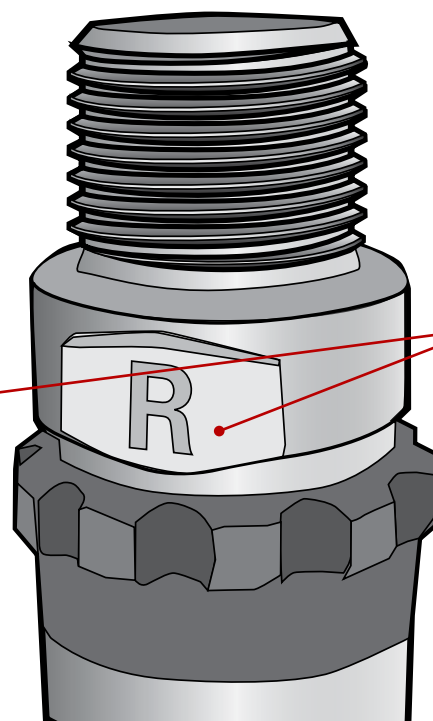

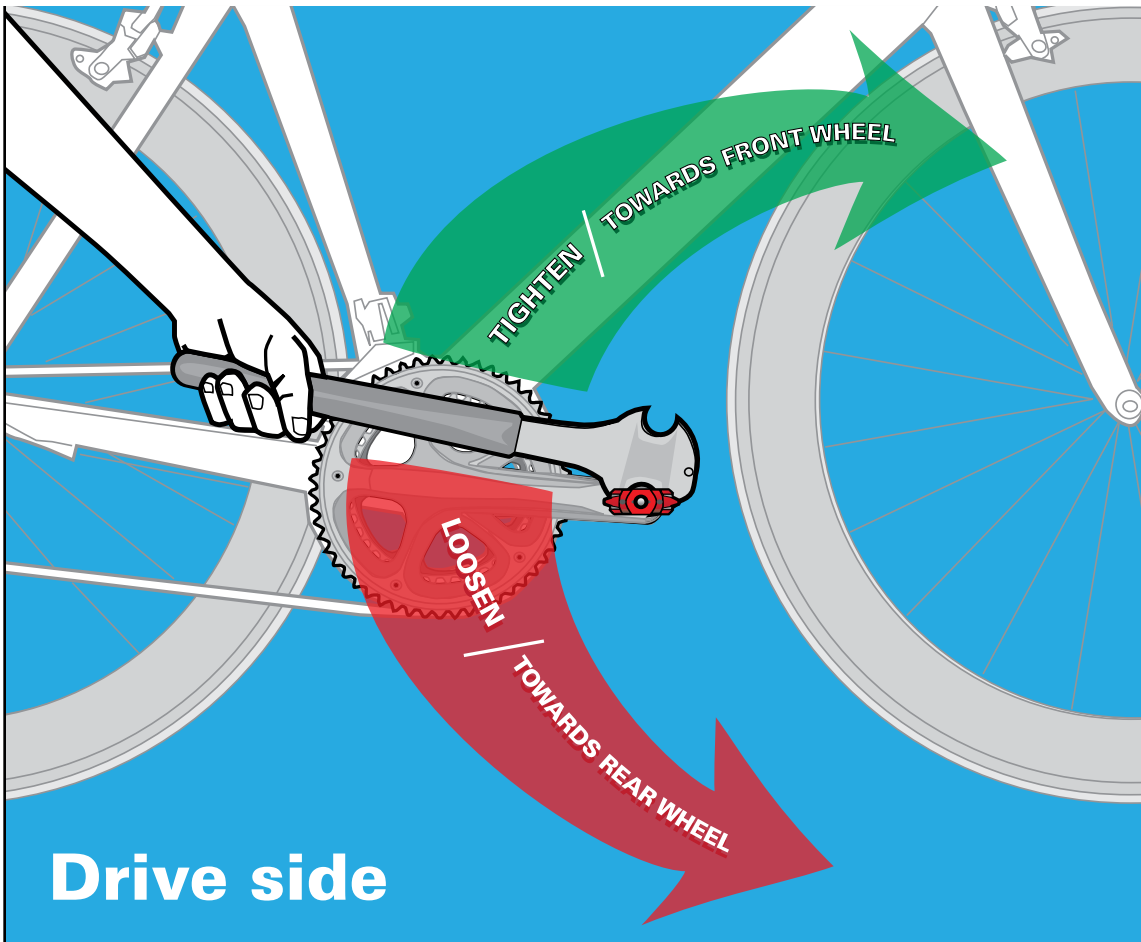

DRIVE SIDE:

Tighten -

Turn towards (over the top) the front wheel.

Loosen -

Turn towards (over the top) the back wheel.

Drive side

NON-DRIVE SIDE:

Tighten -

Turn towards (over the top) the front wheel.

Loosen -

Turn towards (over the top) the back wheel.

ALSO:

Shift chain to largest chainring. to put the chain over chainring teeth helping protect knuckles against greasy abrasions, if the wrench were to accidentally slip.

Try different wrench positions to gain a good mechanical advantage between wrench and crank arm. Pedals are often fastened very securely & can require some extra effort to remove. If possible, hold the opposite crankarm for as an opposite point of leverage.

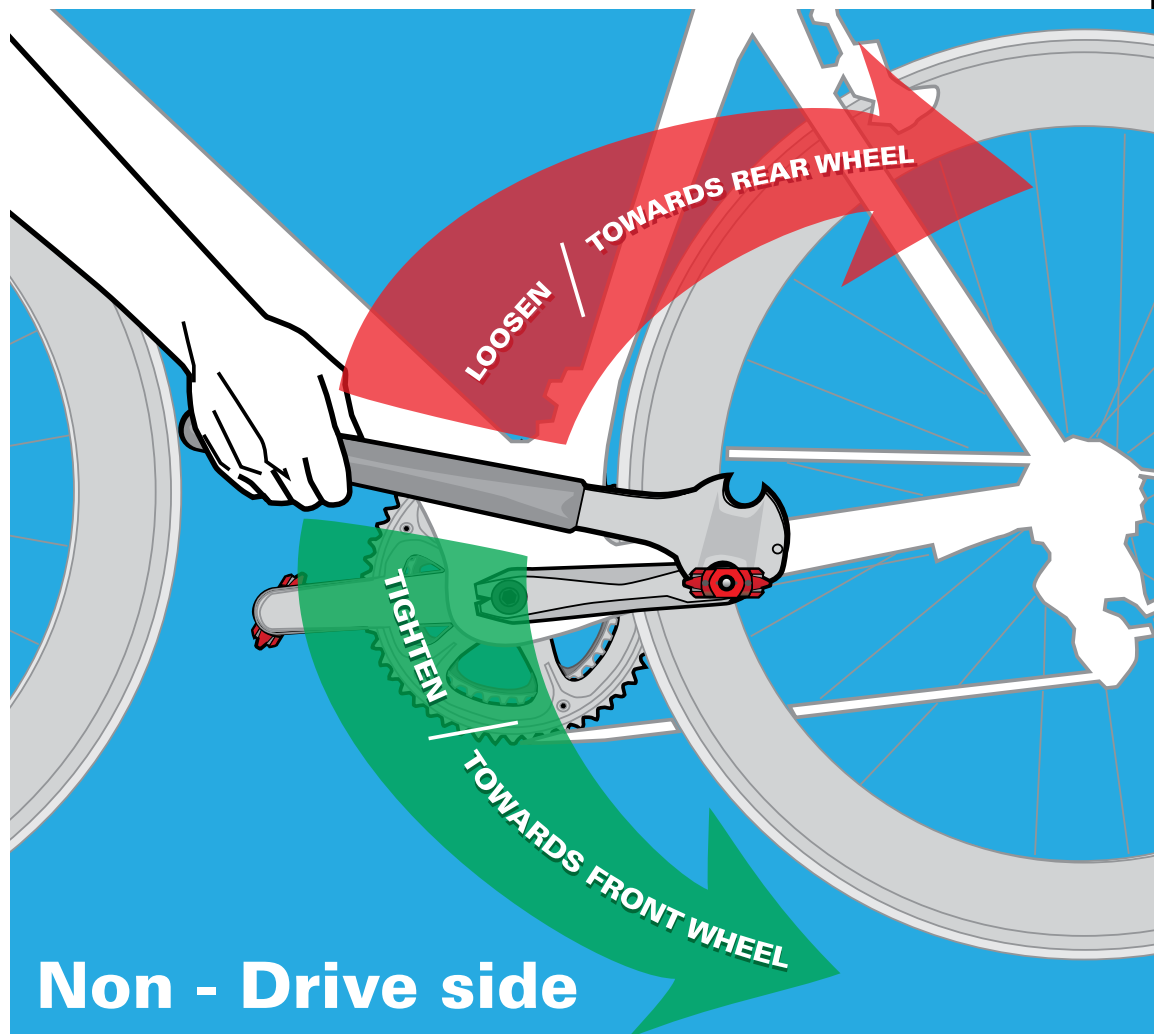

Non - Drive side