

ASSEMBLY PLAN

JAMBETTE PLAYGROUND
EQUIPMENTS INC.

700, DES CALFATS, LÉVIS, QC.
G6V 9E6

Rév.: 27.11.2018

X

M.E.L.

LA-9709-D

Whale Spring Rider

(On stringer)

CSA - ASTM

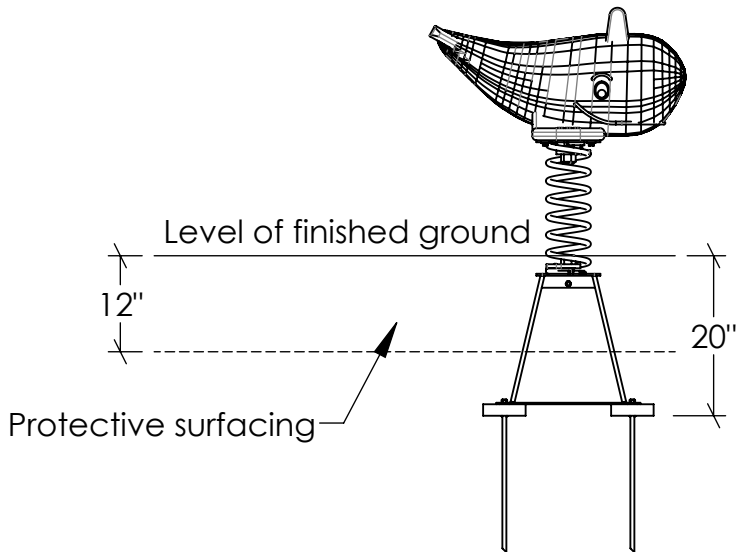
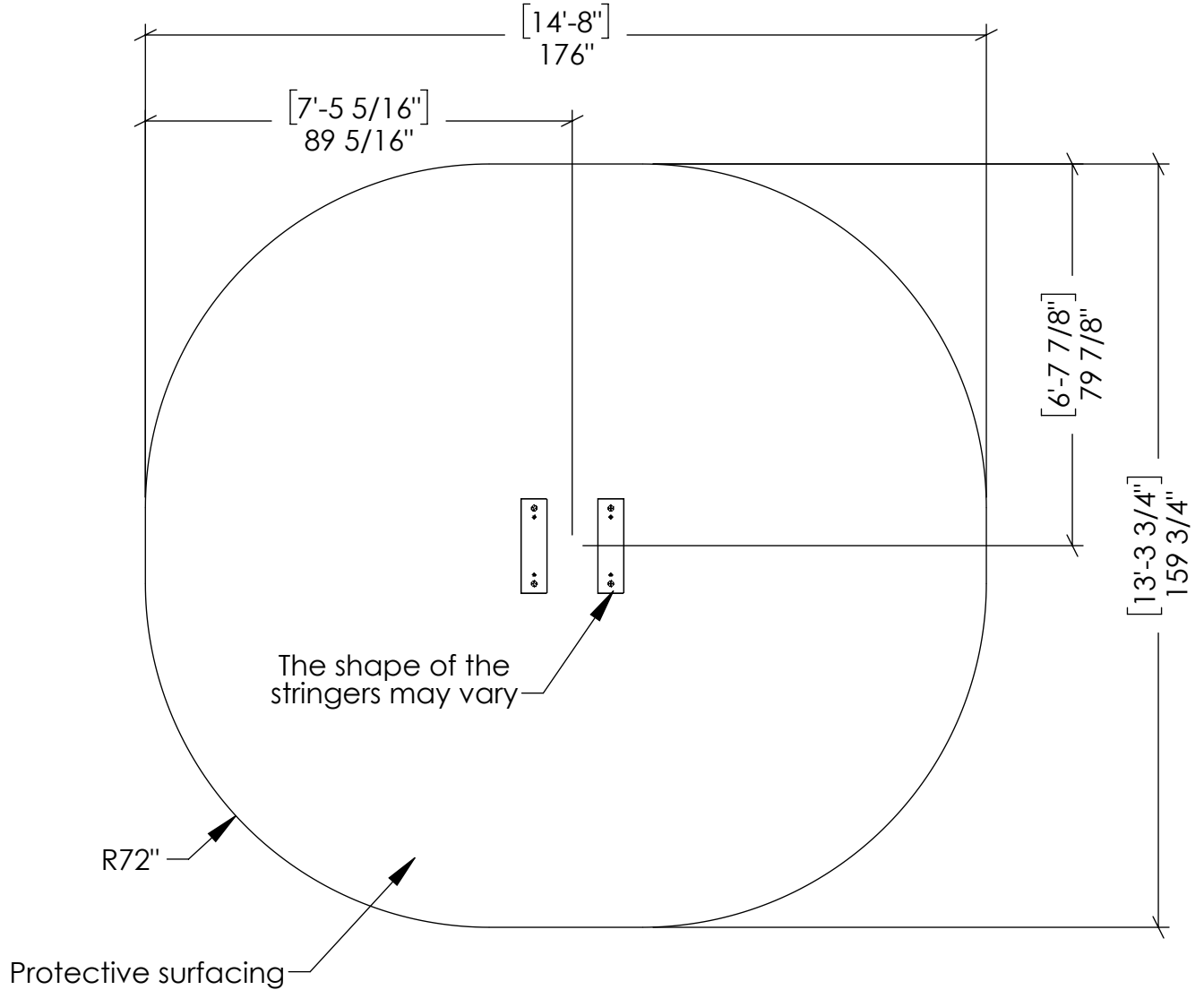

Plan view of the product:

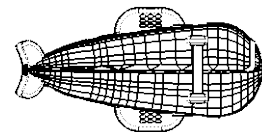

ASSEMBLY PLAN

De référence :

JAMBETTE PLAYGROUND
EQUIPMENT INC.

Rév.:
27.11.2018

X

M.E.L.

LA-9709-D

700, DES CALFATS, LÉVIS, QC.
G6V 9E6

Whale Spring Rider

(On stringer)

CSA - ASTM

Item	Description	Qty.	Number
1	1/2" x 19" Anchor peg (Oiled)	4	a11764
2	Whale spring rider with anchoring	1	*33241

Note : A few hours after the installation, tighten the nuts as many time needed to stabilise the pieces. Afterwards, verify periodically the nuts at each end of the spring.

