

ASSEMBLY PLAN

JAMBETTE PLAYGROUND
EQUIPMENTS INC.

700, DES CALFATS, LÉVIS, QC.
G6Y 9E6

Rév.:
23/02/2021

A.D.

LA-21000

Rorqual spring rider

(On stringer)

CSA - ASTM

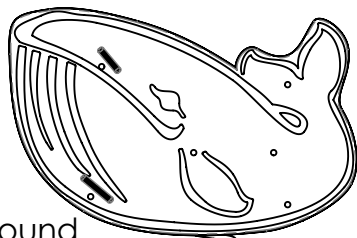
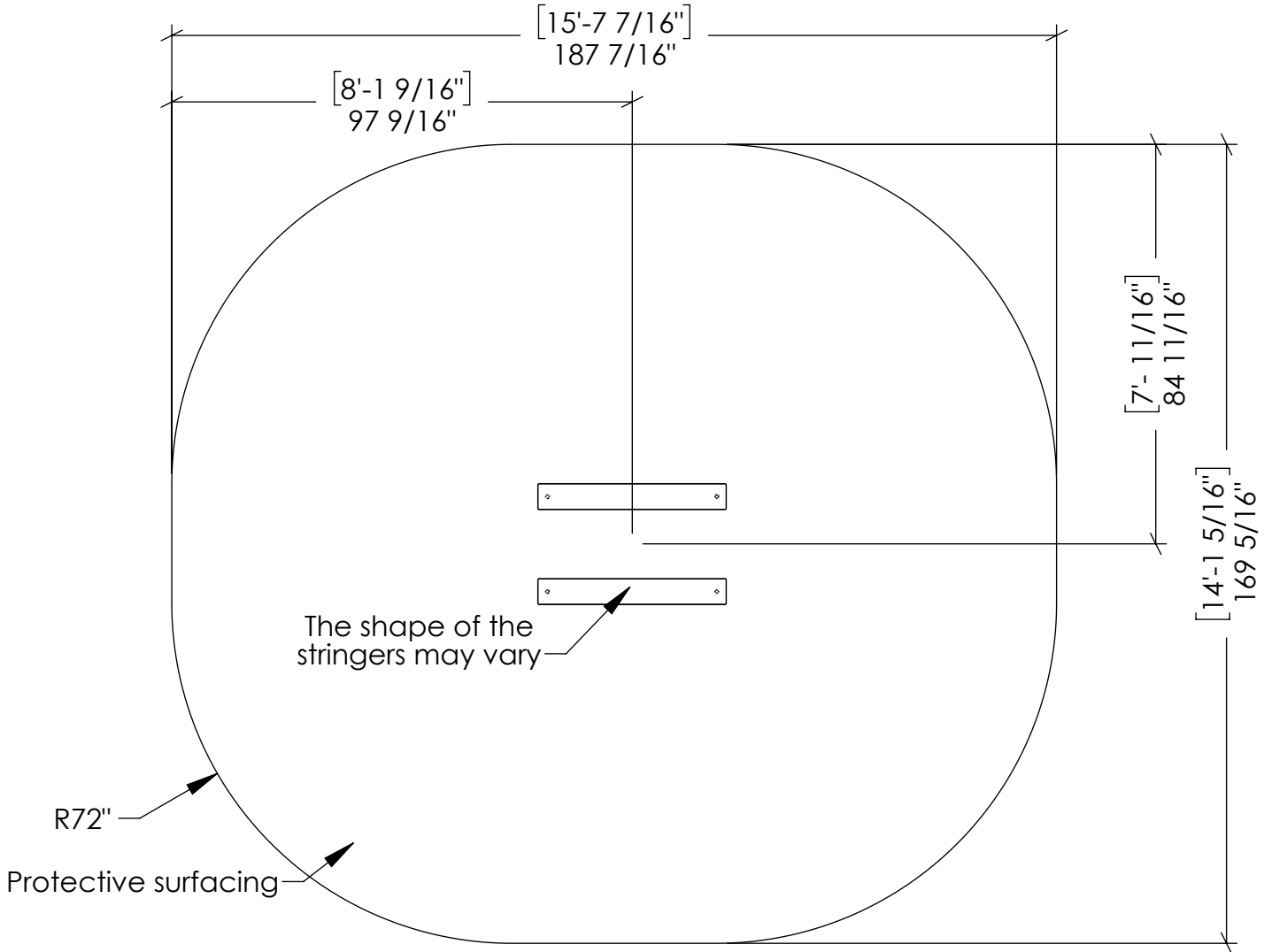

Level of finished ground

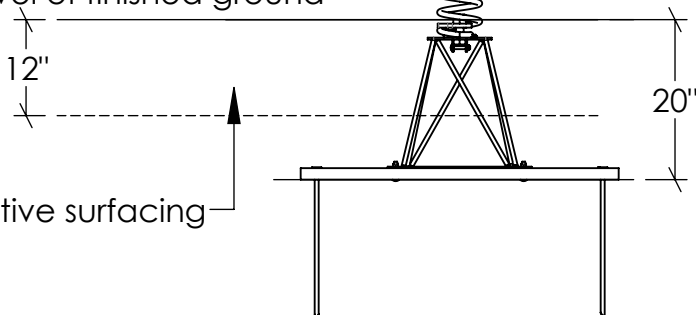

Protective surfacing

Plan view of the product:

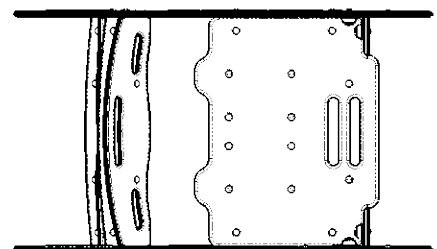

ASSEMBLY PLAN

De reference :

JAMBETTE PLAYGROUND
EQUIPMENTS INC.

700, DES CALFATS, LÉVIS, QC.
G6Y 9E6

Rév.:
23/02/2021

A.D.

LA-21000

Rorqual spring rider

(On stringer)

CSA - ASTM

Item	Description	Qty.	Number
1	1/2" x 19" Anchor peg (Oiled)	4	a11764
2	Rorqual spring rider (2 places)(stringer)	1	a34680

Note : A few hours after the installation, tighten the nuts as many time needed to stabilise the pieces. Afterwards, verify periodically the nuts at each end of the spring.

