

# ASSEMBLY PLAN

15/02/2023

EL

( On stringer )

CSA - ASTM

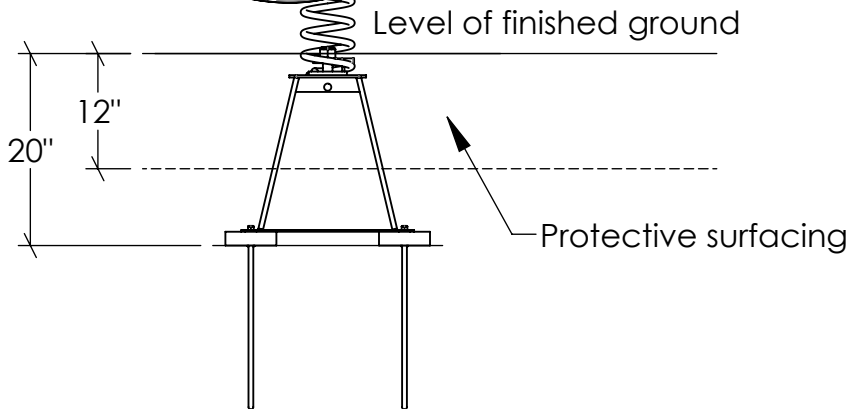
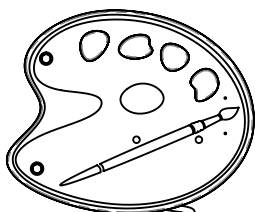
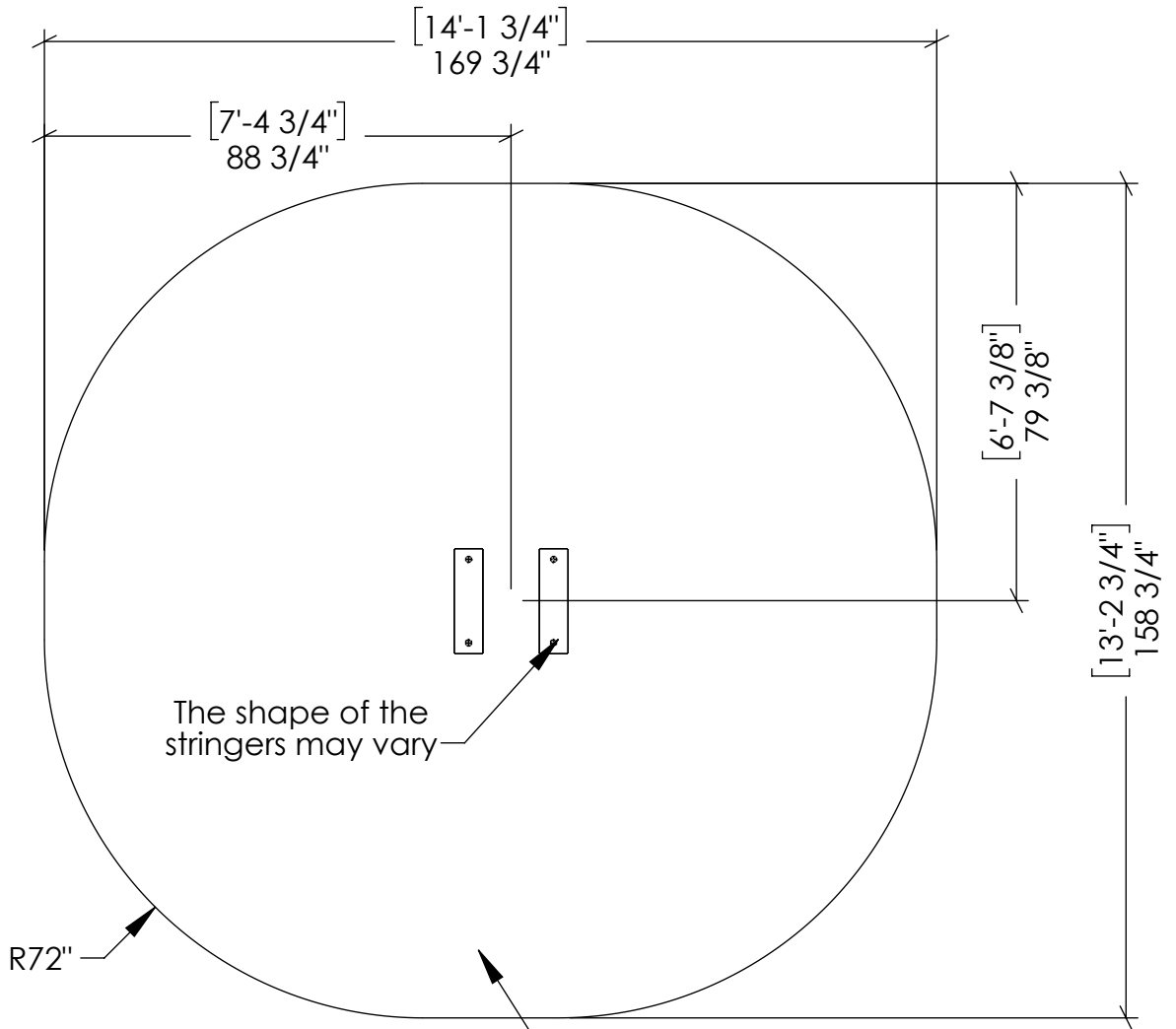

Plan view of the product:

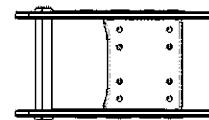

**ASSEMBLY PLAN**

15/02/2023

EL

( On stringer )

CSA - ASTM

Item	Description	Qty.	Number
1	1/2" x 19" Anchor peg (Oiled)	4	α11764
2	Arts Spring Rider	1	α34264

**Note :** A few hours after the installation, tighten the nuts as many time needed to stabilise the pieces. Afterwards, verify periodically the nuts at each end of the spring.

