

# ASSEMBLY PLAN

14/02/2023

EL

( On stringer )

CSA - ASTM

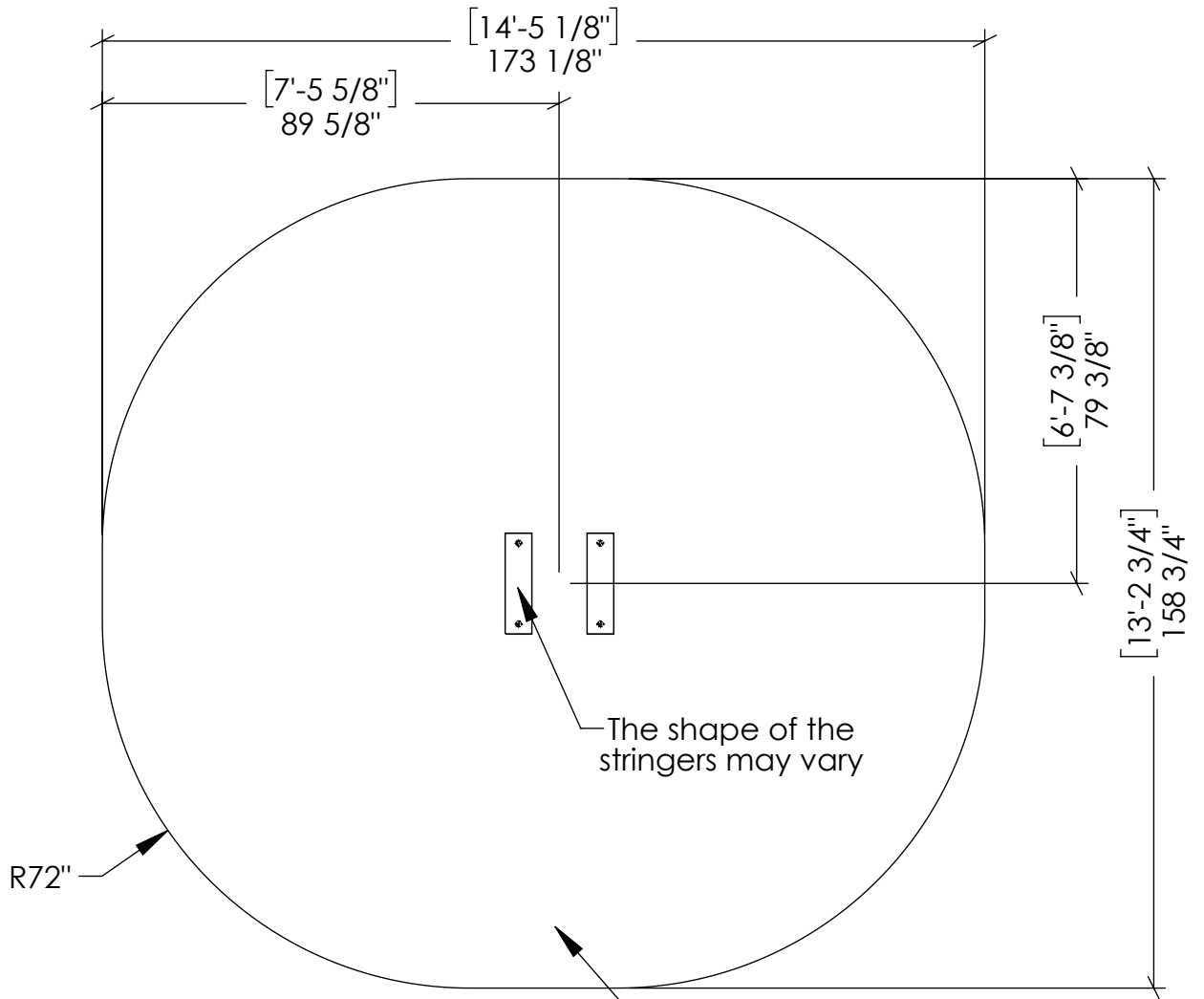

Protective surfacing

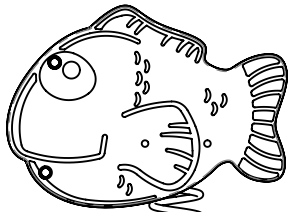

Level of finished ground

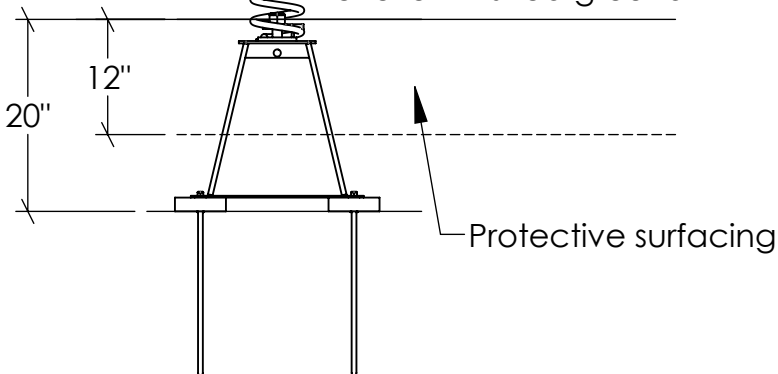

Plan view of the product:

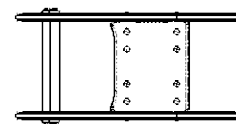

**ASSEMBLY PLAN**

14/02/2023

EL

( On stringer )

CSA - ASTM

Item	Description	Qty.	Number
1	1/2" x 19" Anchor peg (Oiled)	4	a11764
2	Fish spring rider with anchoring	1	*34215

**Note :** A few hours after the installation, tighten the nuts as many time needed to stabilise the pieces. Afterwards, verify periodically the nuts at each end of the spring.

