

ASSEMBLY PLAN

JAMBETTE PLAYGROUND
EQUIPMENTS INC.

700, DES CALFATS, LÉVIS, QC.
G6V 9E6

Rev.:
28.11.2018

X

Agathe

LA-16006

Eco-mobile Spring Rider

(On stringer)

CSA - ASTM

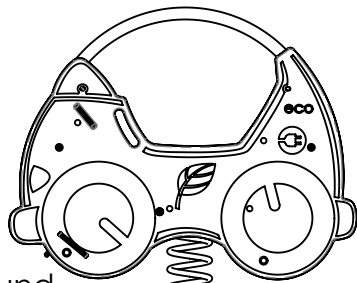
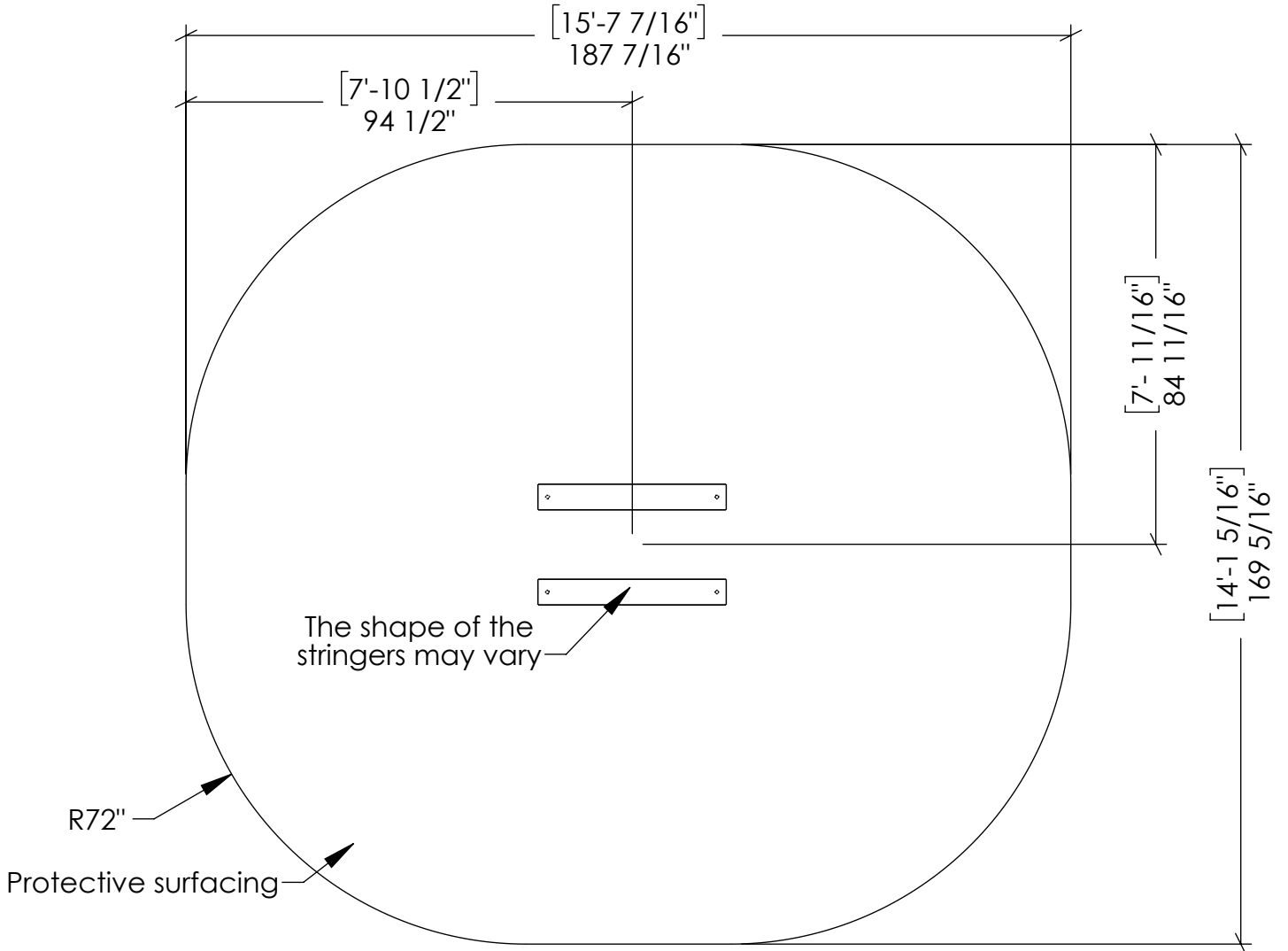

Level of finished ground

12"

20"

Protective surfacing

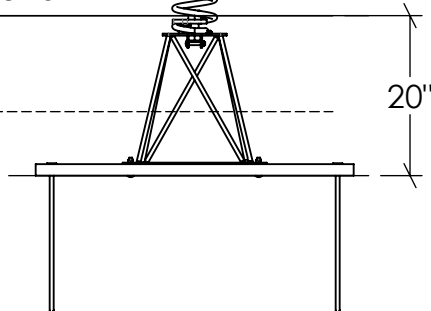

Plan view of the product:

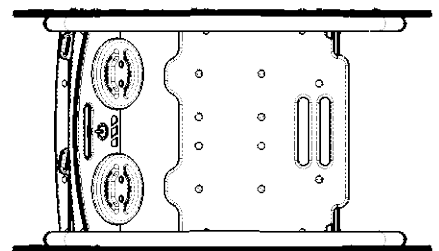

ASSEMBLY PLAN

De reference :

JAMBETTE PLAYGROUND
EQUIPMENTS INC.

Rev.:
28.11.2018

X

Agathe

LA-16006

Eco-mobile Spring Rider

(On stringer)

CSA - ASTM

700, DES CALFATS, LÉVIS, QC.
G6V 9E6

Item	Description	Qty.	Number
1	1/2" x 19" Anchor peg (Oiled)	4	a11764
2	Eco-mobile spring rider	1	a34144

Note : A few hours after the installation, tighten the nuts as many time needed to stabilise the pieces. Afterwards, verify periodically the nuts at each end of the spring.

