

# ASSEMBLY PLAN

27/11/2018

M.E.L.

Horse Spring Rider

CSA - ASTM

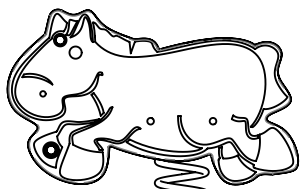
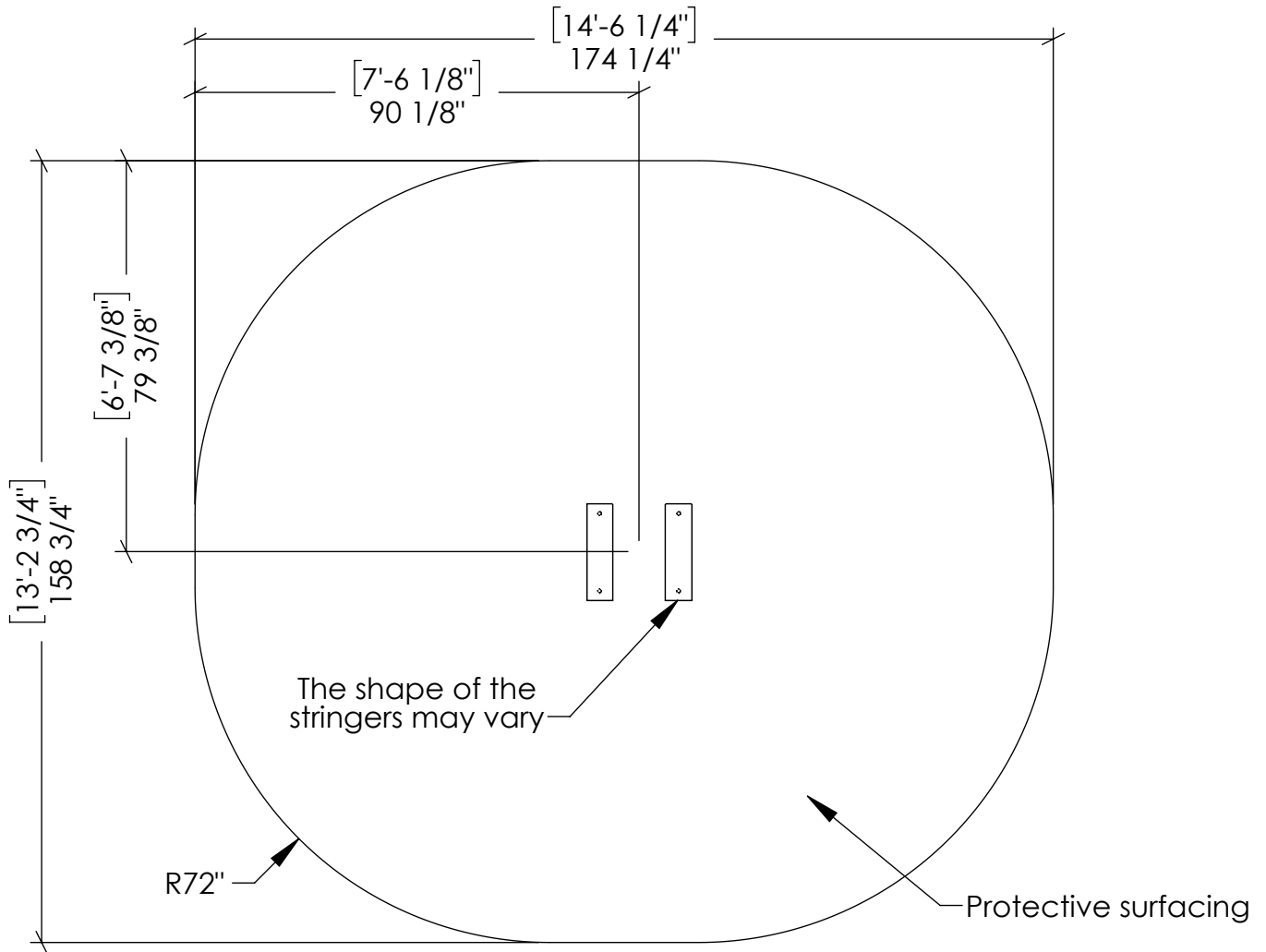

Level of finished ground

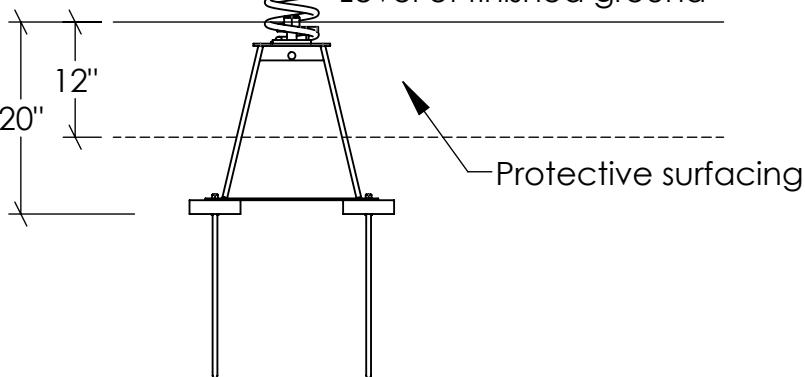

Plan view of the product:

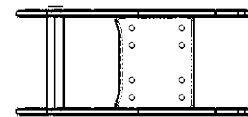

**ASSEMBLY PLAN**

27/11/2018

M.E.L.

Horse Spring Rider

CSA - ASTM

Item	Description	Qty.	Number
1	1/2" x 19" Anchor peg (Oiled)	4	α11764
2	Horse spring rider with anchoring	1	α33239

**Note :** A few hours after the installation, tighten the nuts as many time needed to stabilise the pieces. Afterwards, verify periodically the nuts at each end of the spring.

