

ASSEMBLY PLAN

Solar System Spring Rider

CSA - ASTM

27/02/2023

A.D.

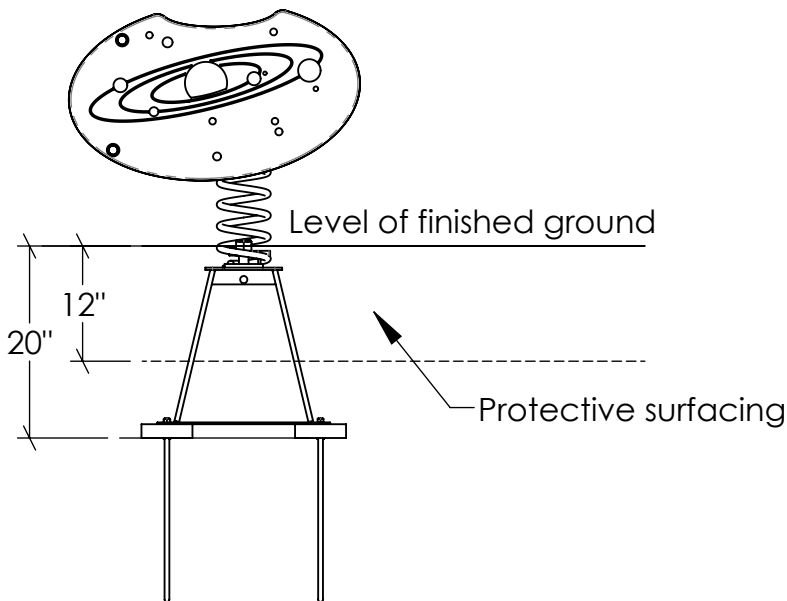
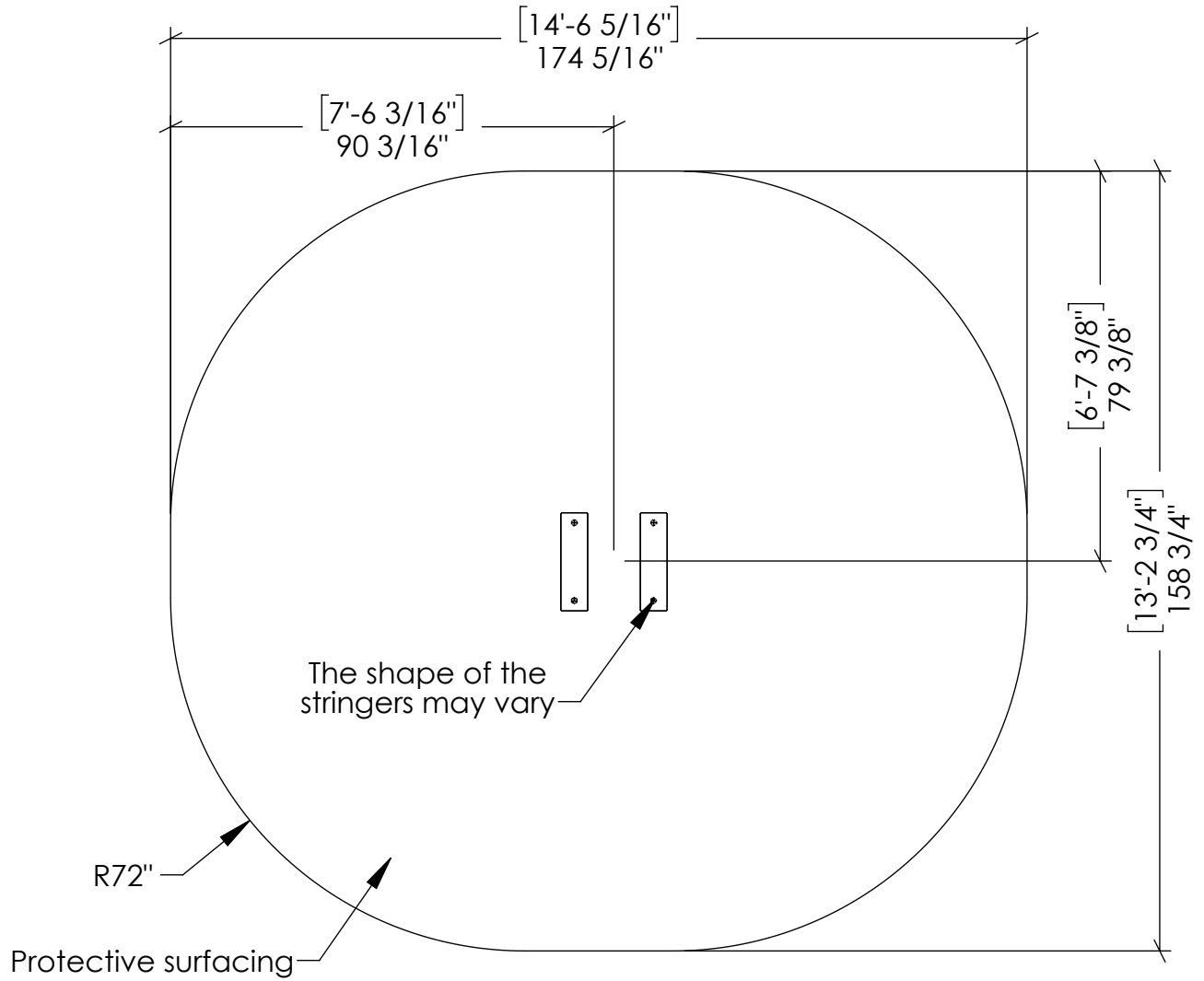

Plan view of the product:

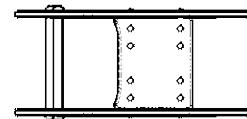

ASSEMBLY PLAN

Solar System Spring Rider

CSA - ASTM

27/02/2023

A.D.

Item	Description	Qty.	Number
1	1/2" x 19" Anchor peg (Oiled)	4	α11764
2	Solar system spring rider	1	α33888

Note : A few hours after the installation, tighten the nuts as many time needed to stabilise the pieces. Afterwards, verify periodically the nuts at each end of the spring.

