

ASSEMBLY PLAN

JAMBETTE PLAYGROUND
EQUIPMENTS INC.

700, DES CALFATS, LÉVIS, QC.
G6V 9E6

Rév.: 29.11.2018

X

M.E.L.

LA-12005-D

Rabbit Spring Rider

(On stringer)

CSA - ASTM

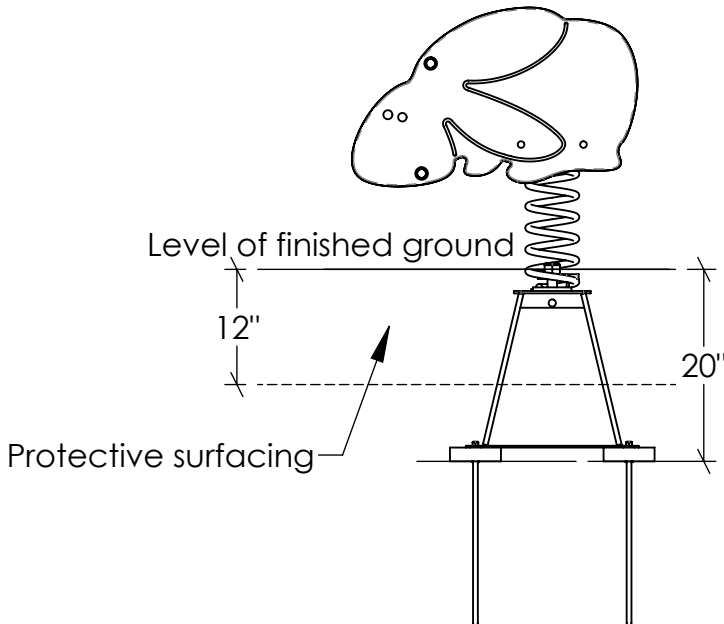
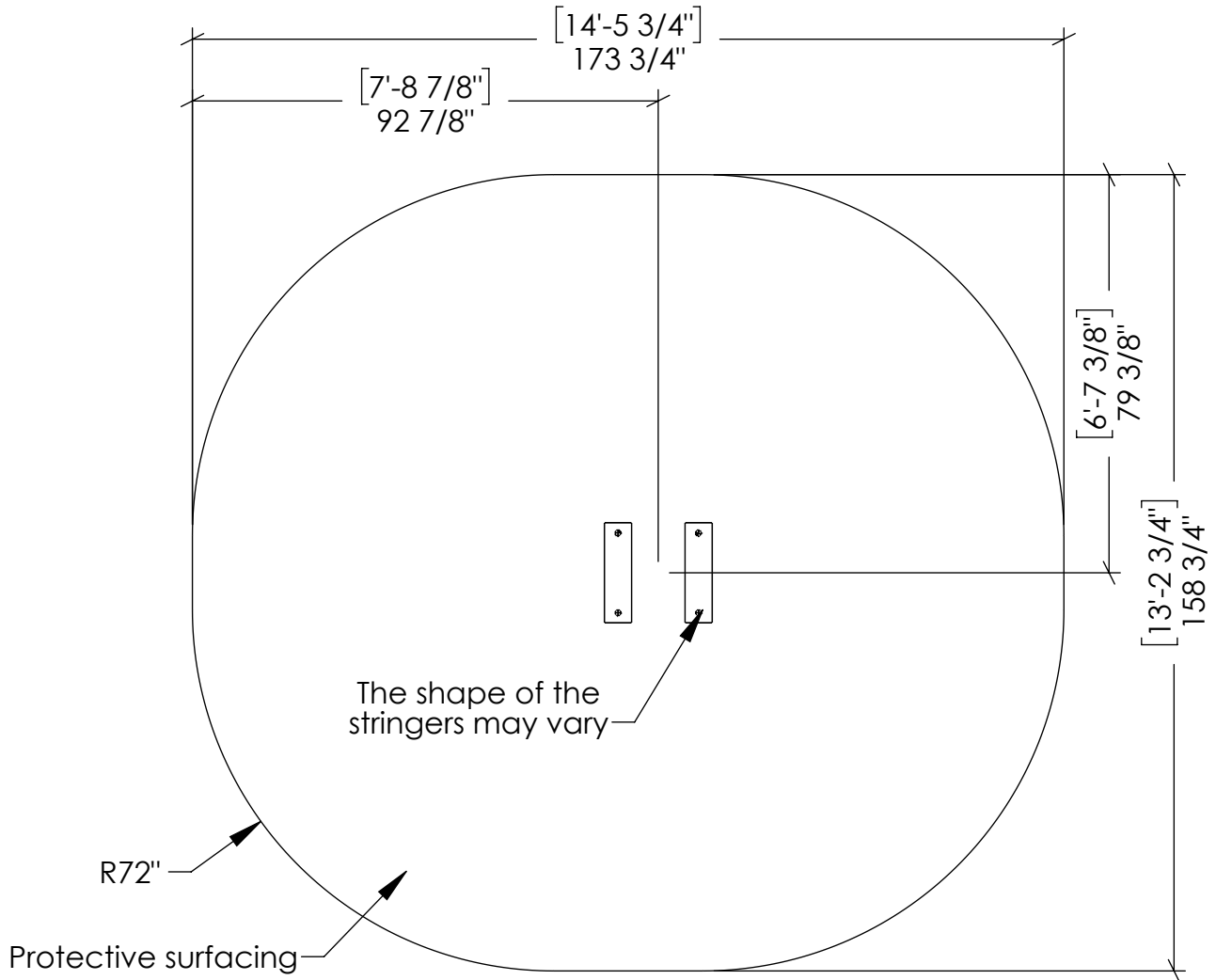

Plan view of the product:

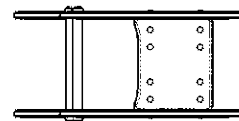

ASSEMBLY PLAN

De référence :

JAMBETTE PLAYGROUND
EQUIPMENTS INC.

Rév.:
29.11.2018

X

M.E.L.

LA-12005-D

Rabbit Spring Rider

(On stringer)

CSA - ASTM

700, DES CALFATS, LÉVIS, QC.
G6V 9E6

Item	Description	Qty.	Number
1	1/2" x 19" Anchor peg (Oiled)	4	α11764
2	Rabbit Spring Rider	1	*33542

Note : A few hours after the installation, tighten the nuts as many time needed to stabilise the pieces. Afterwards, verify periodically the nuts at each end of the spring.

