

# ASSEMBLY PLAN

JAMBETTE PLAYGROUND  
EQUIPMENTS INC.

700, DES CALFATS, LÉVIS, QC.  
G6V 9E6

Rev.: 27.11.2018

Agathe

LA-12003-D

Beaver Spring Rider

( On stringer )

CSA - ASTM

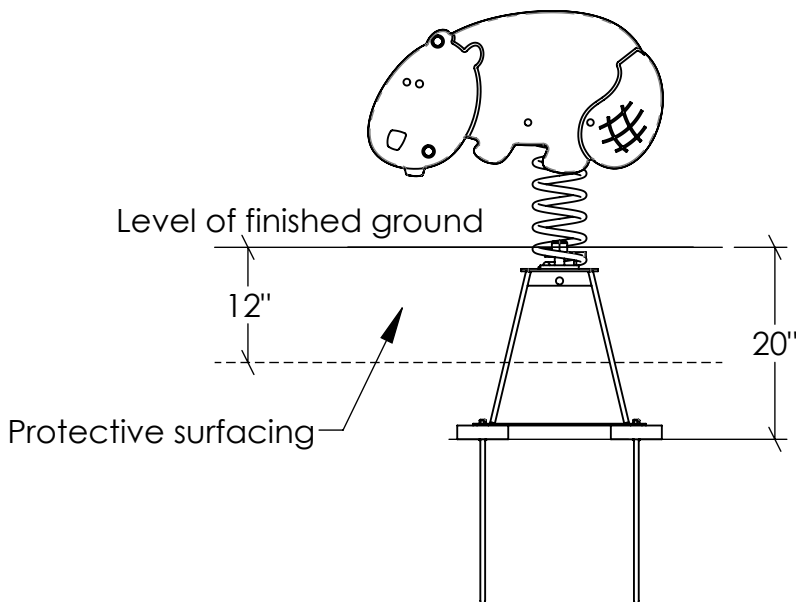
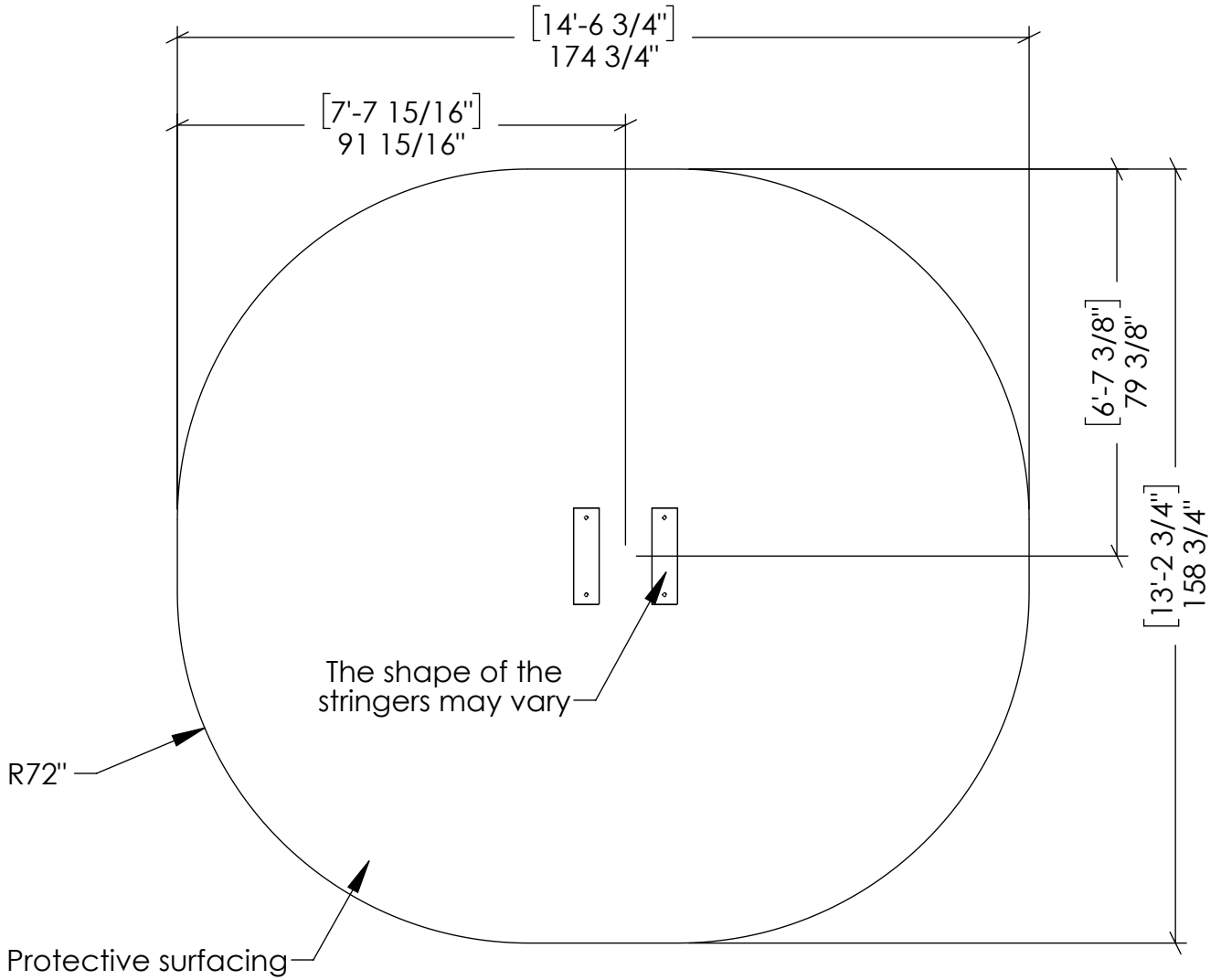

Plan view of the product:

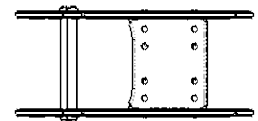

# ASSEMBLY PLAN

# De reference :

JAMBETTE PLAYGROUND  
EQUIPMENTS INC.

Rev.:  
27.11.2018

Agathe

LA-12003-D

700, DES CALFATS, LÉVIS, QC.  
G6V 9E6

Beaver Spring Rider

( On stringer )

CSA - ASTM

Item	Description	Qty.	Number
1	1/2" x 19" Anchor peg (Oiled)	4	α11764
2	Beaver Spring Rider	1	*33540

**Note : A few hours after the installation, tighten the nuts as many time needed to stabilise the pieces. Afterwards, verify periodically the nuts at each end of the spring.**

