

XS300L

Service Manual of Desktop POS Printer

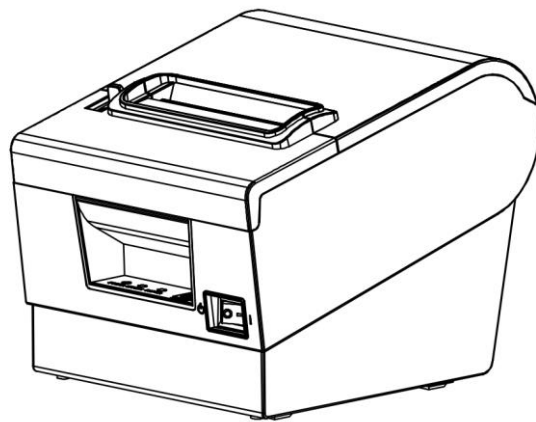

Change Record

Version	Date	Change content	Formulated by	Approved by	Admitted by

Content

Maintenance Attentions	5
1. Printer features	6
1.1 Overview	6
1.2 Main features	6
1.3 Technical parameters	7
2. Appearance and components	8
2.1 Product appearance	8
2.2 Connection diagram of control board components	9
2.3 Printer interface	10
2.3.1 Power interface.....	10
2.3.2 Cash-box interface	10
2.3.3 USB interface	10
2.3.4 Serial interface	11
2.3.5 Ethernet interface	11
3. Buttons, indicator lights and functions	12
3.1 Paper feed key	12
3.2 Power indicator light	12
3.3 State indicator light	12
3.4 Paper shortage indicator light	12
3.5 Printer state description	12
4. Installation and use	13
4.1 Interface connection	13
4.1.1 Connection to the power adapter	13
4.1.2 Connection to the interface cable	13
4.1.3 Connection to the cash-box.....	13
4.2 Paper roll installation.....	14
5. Fault treatment guidelines	15
5.1 Power	15
5.2 Print	15
5.3 Paper feed	16
5.4 Cash-box	16
5.5 Indicator light/buzzer	16
5.6 Communication	17

5.7 Paper cutting	17
6. Dis-assembly and assembly of main components	18
6.1 Printer dis-assembly	18
6.1.1 Remove printer base	18
6.1.2 Remove the printer main board, light board and middle frame iron plater.....	19
6.1.3 Remove the printer weight and power switch	19
6.1.4 Removing the front cover and flip cover of the printer	20
6.1.5 Removing the Printer Clamshell Bracket and Rubber Roller Assembly	20
6.1.6 Disassemble the printer movement	21
6.2 Printer assembly	21
7. Cleaning the printer	22
7.1 Cleaning the print head	22
7.2 Cleaning sensor, rubber roller and paper paths	22
Appendix: printer explosion diagram	23
1. List of printer components	23
2. Explosion diagram of the whole printer	24
3. Decomposition diagram of printer engine	25

Maintenance Attentions

Please read the following attentions carefully before operating the printer:

1. Safety warning



Warning: the print head is a hot component. Do not touch the print head or the surrounding components during and after printing.



Warning: do not touch the print head and connection plug-in to avoid damage of the print head due to static electricity.

2. Attentions

- 1) In the process of troubleshooting, the steps described in the manual shall be strictly followed;
- 2) It is strictly prohibited to plug and unplug the communication cable, replace the print head and maintain the printer when the printer and computer are still running;
- 3) In the process of handling the print head or other electronic components, pay attention to be equipped with anti-static measures;
- 4) The time interval between the start-up and shutdown of the printer shall not be less than 20 seconds;
- 5) The printer shall not print without paper, otherwise it will seriously damage the print rubber roller and the print head;
- 6) Under the condition that the printing effect meets the requirements for use, it is suggested that users set the printing concentration at a low level as far as possible to improve the service life of the print head;

1. Printer features

1.1 Overview

This printer is a thermal note printer with automatic cutter. With high printing quality, high speed, high stability and other characteristics, it can be widely used in commercial POS system, catering industry and other occasions requiring on-site real-time printing of receipts. It can be connected to other equipment via serial, USB and Ethernet interfaces, while providing drivers for operating systems such as Windows XP/Windows 7/Windows 8/Windows 10/Linux, etc.

1.2 Main features

- ☐●Automatically cut papers.
- ☐●Low-noise and high-speed printing.
- ☐●It adopts the structure design to easily load papers.
- ☐●Built-in wall hanging function.
- ☐●Support for printing with marking paper and continuous paper.
- ☐●Support IP modification across network segments.
- ☐●Support cash-box control.
- ☐●Support retyping and queuing functions.
- Support over-temperature protection of print head and cutter anti-blocking functions.
- Support online upgrade of IAP.
- Support QR code printing in formats of QR Code and PDF417.

1.3 Technical parameters

Model:	S300H
Color:	Black
Printing way:	Thermal sensitivity of direct row-type
Print speed:	300mm/s
Paper roll width:	80mm(79.5±0.5mm)
Paper roll:	Minimum inner diameter is Φ13mm, and maximum outer diameter is Φ83mm
Paper thickness:	0.06-0.08mm
Print width:	72±0.5mm
Paper delivery way:	Paper delivery from the upper position
Print density:	576 points per row or 512 points per row
Line space:	3.75mm (adjustable by command)
Print command:	Compatible with ESC/POS commands
Interface type:	9P serial port +USB+ network port
Character size:	ANK character, Font A: 1.5mm×3.0mm (12×24 points) Font B: 1.1mm×2.1mm (9×17 points) Simplified/complex font: 3.0mm×3.0mm (24×24 points)
Figure:	Monochrome BMP and other image files can be downloaded to FLASH
Bar-code type:	UPC-A/UPC-E/JAN13(EAN13)/JAN8(EAN8)/CODE39/ITF/CODABAR/CODE93/CODE128
QR code:	QR Code and PDF417
Column number:	Font A - 42 columns or 48 columns/Font B - 56 columns or 64 columns / simplified and complex fonts - 21 columns or 24 columns
Extended character list:	PC437(Std.Europe), (Katakana), PC850(Multilingual), PC860(Portugal), PC863(Canadian), PC865(Nordic), (West Europe), (Greek), (Hebrew), (East Europe), (Iran), (WPC1252), PC866(Cyrillic#2), PC852(Latin2), (PC858) , (IranII), (Latvian), (Arabic) and (PT1511251)
Reliability:	The life of the engine is 150 kilometers and the life of the cutter is 1 million times
Paper cutting way:	Semi-cutting
Paper presence detection:	Support
Black label detection:	Support
Input buffer:	2048Kbytes
NV Flash:	256Kbytes
Adapter voltage input:	AC 100-240V/50~60Hz
Adapter voltage output:	DC 24V/2.5A
Cash-box control:	DC 24V/1A
Working environment:	Temperature: 0~45°C; humidity: 10~80% (non-condensate)
Storage environment:	Temperature: -10~60°C; humidity: 10~90%
Operating system:	Win 2000 /Win 2003 /Win XP /Win Vista/Win 7 /Win 8/ Win 10 /Linux
Boundary dimension:	194.5*145*147mm (L*W*H)
Net weight:	1.45kg

2. Appearance and components

2.1 Product appearance

1--Cover

2--Open-cover push-button

3--Base

4--Power supply indicator lamp
(POWER)

5--Error indicator lamp (ERROR)

6--Mispaper indicator (PAPER)

7--Paper button (FEED)

8--Power supply switch

9--Front cover

10--Rubber roller

11--Rubber roller gear

12--USB interface

13--Serial interface

14--Ethernet interface

15--Cash box interface

16--Power supply interface

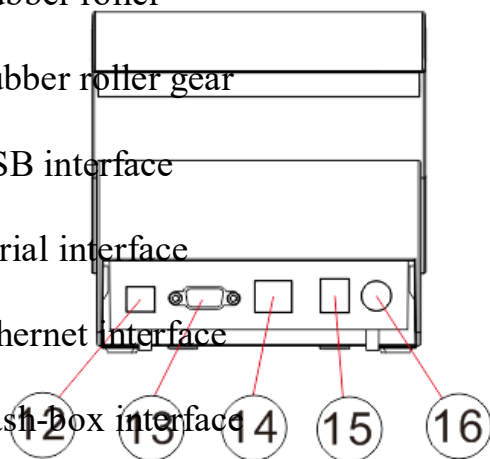
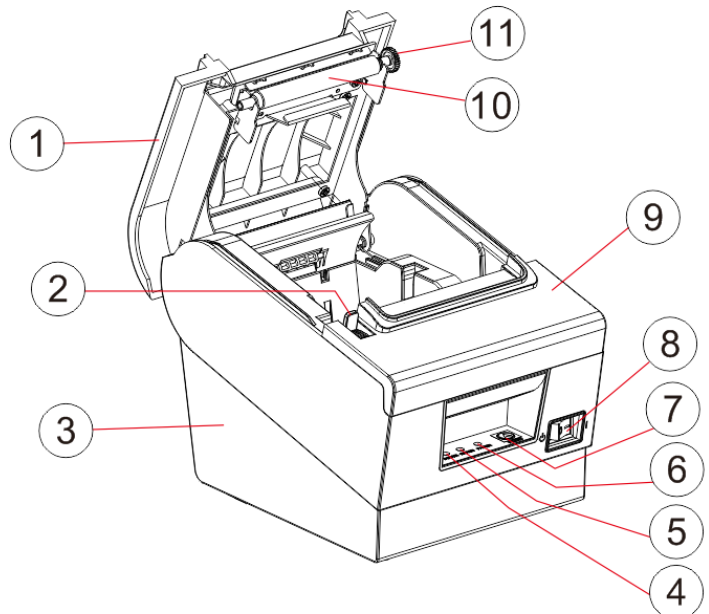

2.2 Connection diagram of control board components

The main control board, printing engine, cutter, keys, etc. are adopted for the printer to connect to the main control board through the connector or transfer board. The following is the connection diagram of the serial port +USB+ network port control board components:

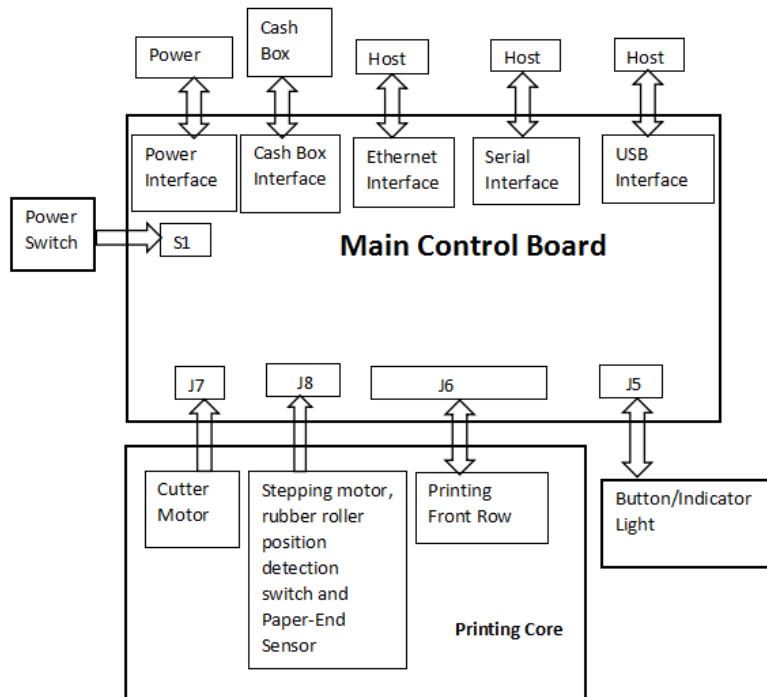

Fig2.2.1 Connection diagram of serial port +USB+ network port control board

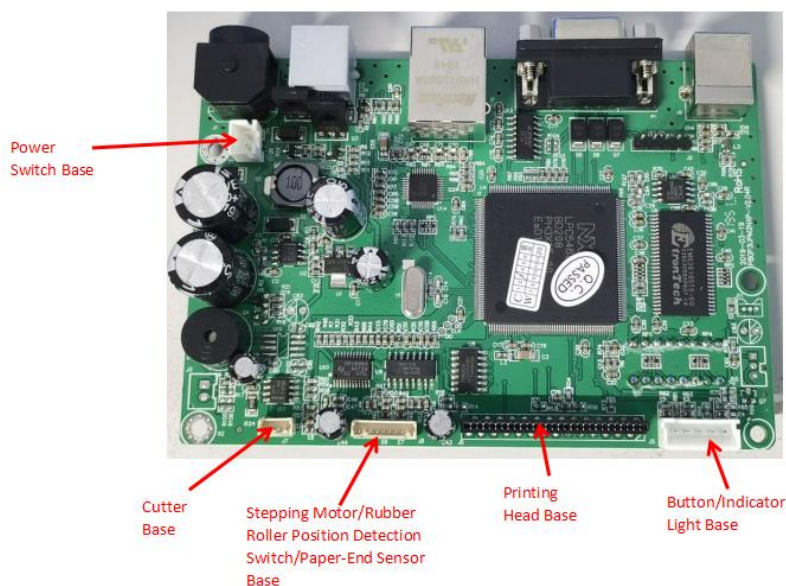
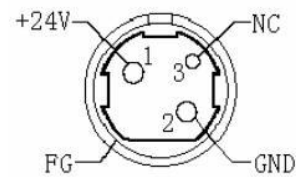

Fig 2.2.2 Position Diagram for serial port +USB+ Network Interface Control Panel

2.3 Printer interface

2.3.1 Power interface

PIN	SIGNAL NAME
1	+24V
2	GND
3	N.C
SHELL	F.G



2.3.2 Cash-box interface

Cash-box control: 6-wire RJ-11 socket, output DC 24V/1A power signal to drive the cash-box for action.

PIN	SIGNAL NAME
1	FGND
2	Drawer 1
	SW
	CASH
	Drawer 2
	GND

A diagram of an RJ-11 socket connector with 6 pins. The part number '654321' is visible at the bottom left of the diagram.

2.3.3 USB interface

PIN	SIGNAL NAME
1	VBUS
2	D- (DATA-)
3	D+ (DATA+)
4	GND

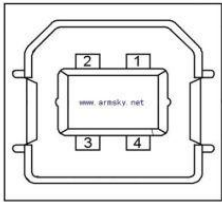

2.3.4 Serial interface

PIN	SIGNAL NAME
1	-
2	TXD
3	RXD
4	-
5	GND
6	DSR
7	-
8	CTS
9	-

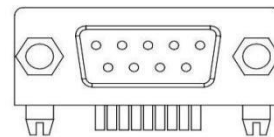

2.3.5 Ethernet interface

PIN	SIGNAL NAME
1	TD+
2	TD-
3	RD+
4	TXC
5	RCT
6	RD-
7	-
8	-
9	GREEN+
10	GREEN -

11	YELLOW+
12	YELLOW-

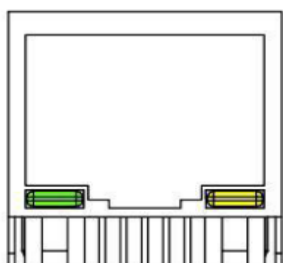

3. Buttons, indicator lights and functions

3.1 Paper feed button ()

Under the condition that the printer does not alarm, press this key to deliver paper, and press this key continuously to deliver paper continuously.

3.2 Power indicator light ()

The color of the indicator light is blue. That the light is on indicates that the printer is powered on, while that the light is off indicates that the printer is powered off.

3.3 Error indicator light ()

The color of the indicator light is red. When the printer is out of paper, or there is something wrong with the cutter, or the print head is overheated, or there are other errors, the light flashes.

3.4 Paper shortage indicator light ()

The color of the indicator light is red. The light and the error light are on at the same time, indicating that the printer is short of paper. The light and the error light are off at the same time, indicating that the printer has

paper.

3.5 Description of printer state

- Error state

Including print head overheating, cover opening, lack of paper, cutter block and paper block, etc.

- Standby state

Printer has no errors without printing or paper feed to wait for printing task.

- Print state

The process from starting to print to the moment when the contents to be printed are printed after the print contents are received completely.

- Paper delivery state

The process from paper delivery to paper cutting before the printing is completed.

4. Installation and use

4.1 Interface connection

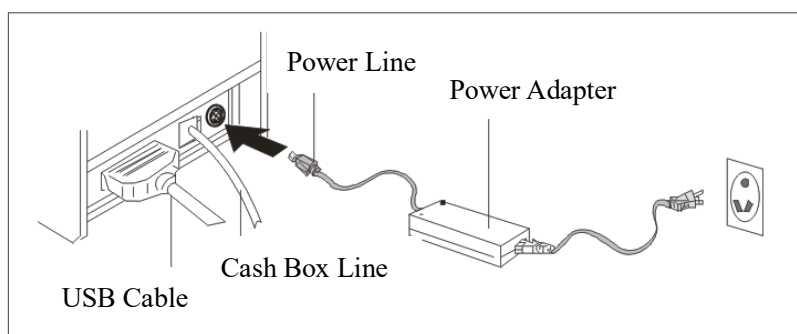

Fig. 4.1.1 Interface connection diagram

Note: the printer transmission interface in the picture will vary according to the type of machine you purchased. Please refer to the actual interface.

4.1.1 Connection to the power adapter

1) Confirm that the power switch of the printer is off;

- 2) Plug the power adapter cable plug facing straight up into the power interface at the back of the printer;
- 3) Switch on the input power of the power adapter;
- 4) Pay attention to the correct use of plugging and unplugging power adapter, otherwise it is easy to cause damage.

 **Attentions:**

- 1) Please use an exclusive power adapter or the matched product;
- 2) When the plug of the power adapter is inserted and unplugged, the connector housing of the plug shall be held in hand to avoid pulling the cable forcibly;
- 3) Dragging the power adapter cable shall be avoided, otherwise it will damage the cable and cause fire and electric shock;
- 4) Placing power adapters around overheated equipment shall be avoided, otherwise the cable surface will melt, causing fire and electric shock;
- 5) If you do not use the printer for a long time, please disconnect the power of printer power adapter.

4.1.2 Connection to the interface cable

- 1) Confirm that the power switch of the printer is off;
- 2) Insert the interface cable into the matched interface and fix it with screws (or snap spring) on the plug;
- 3) Connect the other end of the interface cable to the host.

4.1.3 Connection to the cash-box

- 1) Confirm that the power switch of the printer is off;
- 2) Insert the cash-box connection cable into the cash-box interface at the back of the printer.



Warning: the cash-box interface can only be connected to the cash-box devices with a voltage of 24V/1A (it shall not be connected to telephone lines, etc.).

4.2 Paper roll installation

After the connection between the power adapter and the interface cable is completed, the medium can be installed for printing. Before printing, the paper specification used by the printer shall be confirmed. This printer only supports 80mm-wide thermal paper rolls.

- 1) Turn off the power of the printer;
- 2) Press the uncapping button to open the printer flap;
- 3) Put the paper rolls into the printer and pay attention to the placement direction of the paper rolls;
- 4) Close the printer flap.

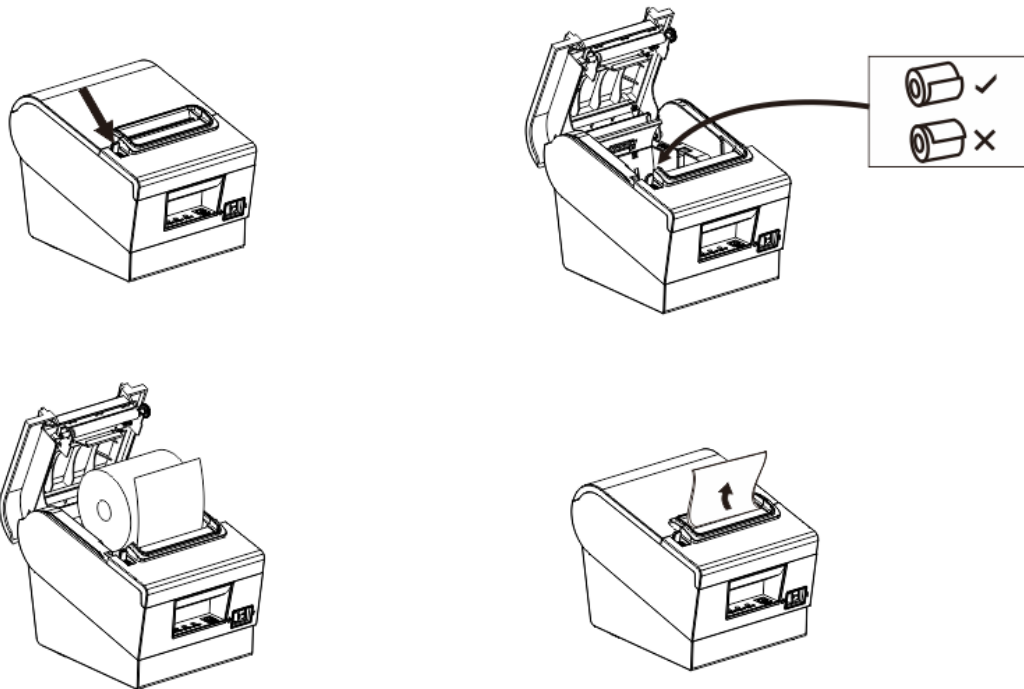

5. Fault treatment guidelines

In case of printer failure, please refer to this chapter for corresponding treatment. If you still can't fix the problem, please contact the agent or manufacturer.

5.1 Power

Fault	Possible cause	Solution
The power indicator light is off	The AC/DC power adapter is not connected properly	Reconnect the power adapter
	AC/DC power adapter is in fault	Replace the power adapter
	The power supply circuit of the main control board is out of order	Repair or replace the main control board
	Lamp board is in fault	Repair or replace the lamp board

5.2 Print

Fault	Possible cause	Solution
The printer prints without paper	Printer paper is not installed correctly	Install the printing paper according to the instructions in the manual
	The paper characteristics used is incorrect	Use thermal paper for printing
	Print head is damaged	Replace the print head
	The main board is damaged	Repair or replace the main control board
	The printer paper is installed incorrectly	Install the printing paper according to the instructions in the manual
The print quality is poor or print product is blurred.	Paper quality is poor	Use high-quality paper rolls
	The settings are incorrect	Increase print concentration
	The print head is damaged	Replace the print head
The printer prints with dirty spots	The paper is stained with dirt, or the paper quality is poor	Check or replace the printer paper
	The print head is dirty	Clean the print head with alcohol

5.3 Paper feed

Fault	Possible cause	Solution
There is no paper feed or paper feed is abnormal	Paper is blocked in the printer	Clear the blocked paper and install the printing paper according to the operation instructions
	Gear is damaged	Replace the gear
	The main board is damaged	Repair or replace the main control board
	Print head motor is in fault	Replace the print head
	There is foreign matter in the gear	Clean the gear

5.4 Cash-box

Fault	Possible cause	Solution
The cash-box cannot be opened	The cash-box cable does not match	Replace with cables of corresponding specification

	Cash-box drive cable is damaged	Replace the cable
	Cash-box drive circuit is damaged	Repair or replace the main control board
The cash-box cannot be closed	Cash-box drive circuit is damaged	Repair or replace the main control board

5.5 Indicator light/buzzer

Fault	Possible cause	Solution
The key or indicator is not working	Key indicator light cable is not reliably connected	Reconnect the cable
	Cable or connector is damaged	Replace cables or connectors
	The key or indicator light is damaged	Replace keys or indicator lights
	state show that the circuit is damaged	Replace or repair the main control board
The buzzer is not working	The buzzer is damaged	Replace the buzzer
	The buzzer control circuit is abnormal	Replace or repair the main control board
	The settings are incorrect	Set according to requirements of the manual

5.6 Communication

Fault	Possible cause	Solution
The printer is in normal condition but does not print	The communication cable is not reliably connected to the printer	Reconnect the communication cable
	The communication cables used do not match	Use a communication cable that matches the printer
	Communication cable or connector is damaged	Replace communication cables or connectors
	Communication interface board is damaged	Replace the communication interface board
	Extension interface circuit of main control board is in fault	Repair or replace the main control board

5.7 Paper cutting

Fault	Possible cause	Solution
Cutter is blocked	The blade is deformed	Change the cutter
	Motor is burnt out	Change the cutter
	Paper scrap is accumulated	Clean up the scraps of paper on each transmission component
Paper is blocked	Head piece is overheated	Reduce the heating power of the drive head piece
	The paper feed position is wrong	Place the paper parallel to the side of the paper slot between the rubber roller and TPH
Continuous paper cutting	The blade is worn or damaged	Change the cutter
	The paper is too thick	Change for standard paper

6. Dis-assembly and assembly of main components

Attentions during operation:

- 1) When the printer is working normally, do not remove any components of the printer or loosen any screws of the printer;
- 2) When you are disassembling and assembling components, please carefully check whether the connecting wires are damaged;
- 3) When you are handling the printer engine and electronic components, pay attention to take anti-static measures;
- 4) During the dis-assembly and assembly process, do not let screws or other components into the printer;
- 5) Pay attention to avoid damage to the printer engine during assembly and dis-assembly.

Maintenance tools: cross screwdriver, cutting pliers.

Auxiliary materials: grease, alcohol, absorbent cotton ball.

6.1 Printer dis-assembly

6.1.1 Remove the printer base

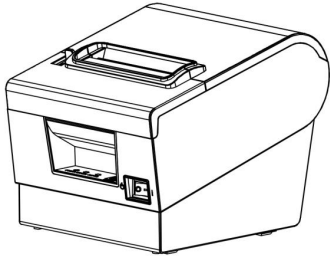
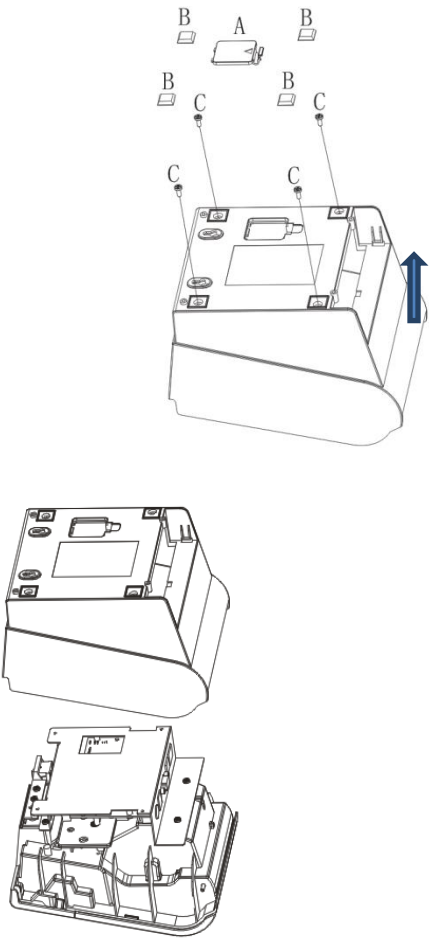
Explanatory chart	Diagram
	<p>Printer appearance figure</p>
	<p>A. Remove the battery cover first. B. Then remove the 4 "T" shaped foot pads. C. Use a Phillips screwdriver to remove the 4 H3*6mm screws fixing the base. Then remove the base in the same direction.</p>

6.1.2 Remove the printer main board, light board and middle frame iron plate

Explanatory chart	Diagram
-------------------	---------

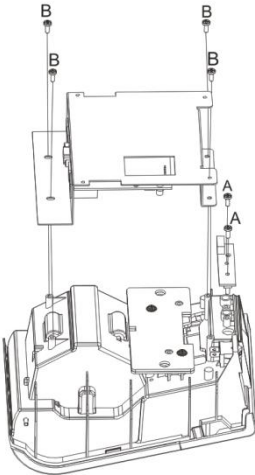
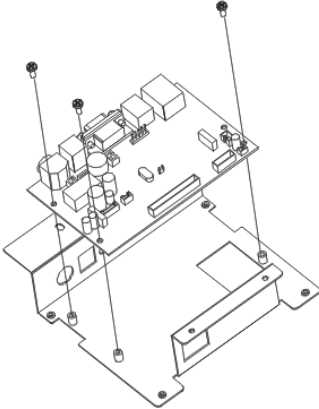
	<p>A. Use a Phillips screwdriver to remove the 2 PA3*8mm screws that fix the light board, and then remove the light board.</p> <p>B. Use a Phillips screwdriver to remove the 4 PA3*8mm screws securing the middle frame iron plate, and then remove the middle frame iron plate.</p>
	<p>Use a Phillips screwdriver to remove the 3 H3*6mm screws securing the motherboard, and then remove the motherboard.</p>

6.1.3 Remove the printer weight and power switch

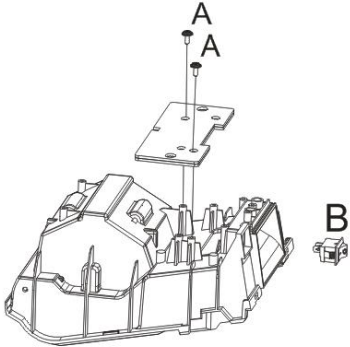
Explanatory chart	Diagram
	<p>A. Remove the two PWA3 * 10mm screws with the cross screwdriver, and then remove the weighted insert.</p> <p>B. Remove the power supply switch.</p>

6.1.4 Removing the front cover and flip cover of the printer

Explanatory chart	Diagram
-------------------	---------

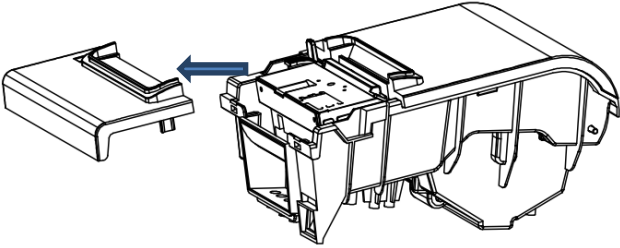
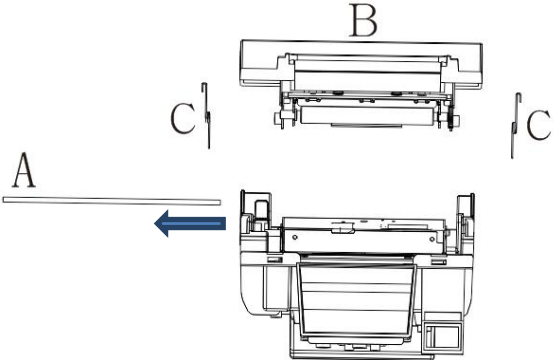
	<p>Remove the front cover in the direction.</p>
	<p>A. First take out the fixed shaft from the side. B. Take out the flip cover upwards. C. Remove the left/right torsion spring from the flip bracket.</p>

6.1.5 Removing the Printer Clamshell Bracket and Rubber Roller Assembly

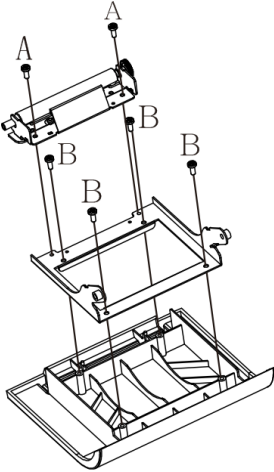
Explanatory chart	Diagram
<p>1</p> 	<p>A. Use a Phillips screwdriver to remove the 2 H3*6mm screws that fix the rubber roller assembly, and then remove the rubber roller assembly. B. Use a Phillips screwdriver to remove the 4 PA3*8mm screws that fix the flip bracket, and then remove the flip bracket.</p>

6.1.6 Disassemble the printer movement

<p>图示</p>	<p>图解</p>
-----------	-----------

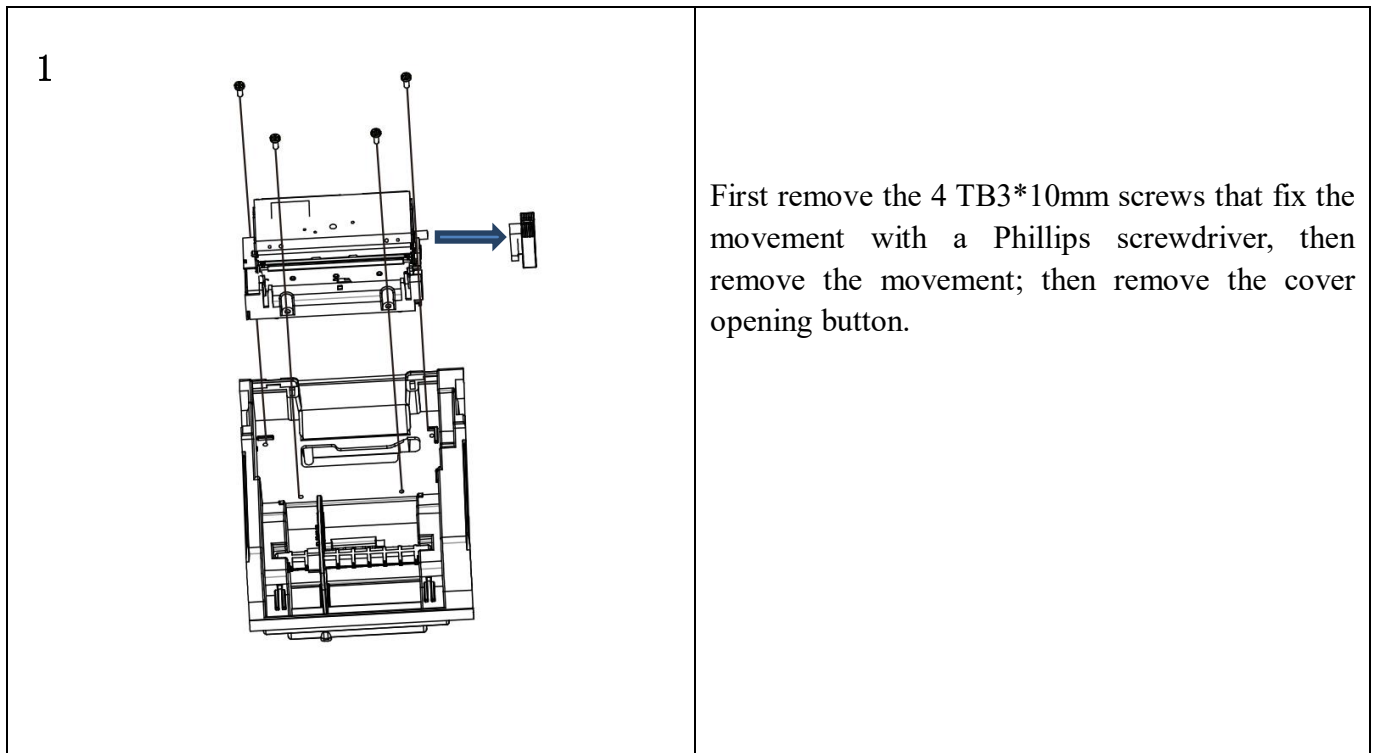

6.2 Printer assembly

When you are assembling, simply assemble in the reverse order of dis-assembly.

7. Cleaning the printer

Dust, foreign matter, stickum or other contaminants that stick to inside print head or printer may degrade the print quality. At the time of decontamination, please clean the print head according to the following

methods.

7.1 Cleaning the print head

- 1) Please open the cover of the printer and clean with a cleaning pen or cotton swab stained with diluted alcohol (alcohol or isopropanol) from the center of the print head to the sides.
- 2) After cleaning the print head, do not use the printer immediately, wait for the clean alcohol used to evaporate completely (1 to 2 minutes), and the print head must be completely dry before use.

7.2 Cleaning sensor, rubber roller and paper paths

- 1) Please open the flap of the printer and take out the paper roll.
- 2) Use dry cotton cloth or cotton swab to remove dust or foreign matters.
- 3) Soak cotton cloth or cotton swab with medical alcohol and wipe away sticky foreign matters or other contaminants with it.
- 4) Do not use the printer immediately after cleaning components, wait for the alcohol to evaporate completely (1 to 2 minutes), and use the printer after it is completely dry.

※ Clean components when print quality or paper detection performance degrades.



Attention

- 1) Be sure to turn off the power of the printer before cleaning.
- 2) When the printer is printing, the print head will become very hot; therefore, if you want to clean the print head, turn off the printer power and wait 2 to 3 minutes before starting.
- 3) When you are cleaning the print head, pay attention not to touch the heated component of the print head to avoid its damage caused by static electricity, etc.
- 4) Be careful not to scratch or damage the print head.
- 5) Forceps and other metal tools shall not be used to scratch the surface of print head, rubber roller and sensor.
- 6) Organic solvents such as gasoline, acetone, etc. shall not be used.

Appendix: printer explosion diagram

1. List of printer components

No.	Material name
1	Front cover
2	The front cover
3	open button
4	fixed shaft
5	flip stand
6	baffle
7	long roller
8	printing core
9	left torsion spring
10	right torsion spring
11	short roller
12	middle frame
13	Light board
14	switch
15	weighted tablets
16	telescopic board
17	Roller adjustment plate
18	motherboard
19	Middle frame iron plate
20	hidden wire slot
21	base
22	The key label
23	battery cover
24	T-shaped feet
25	Cutter
26	Cutter holder
27	Stepping motor
28	Speed-reduction gear set
29	Side cover
30	Rubber roller components
31	Print head body
32	Remote lever

2. Explosion diagram of the whole printer

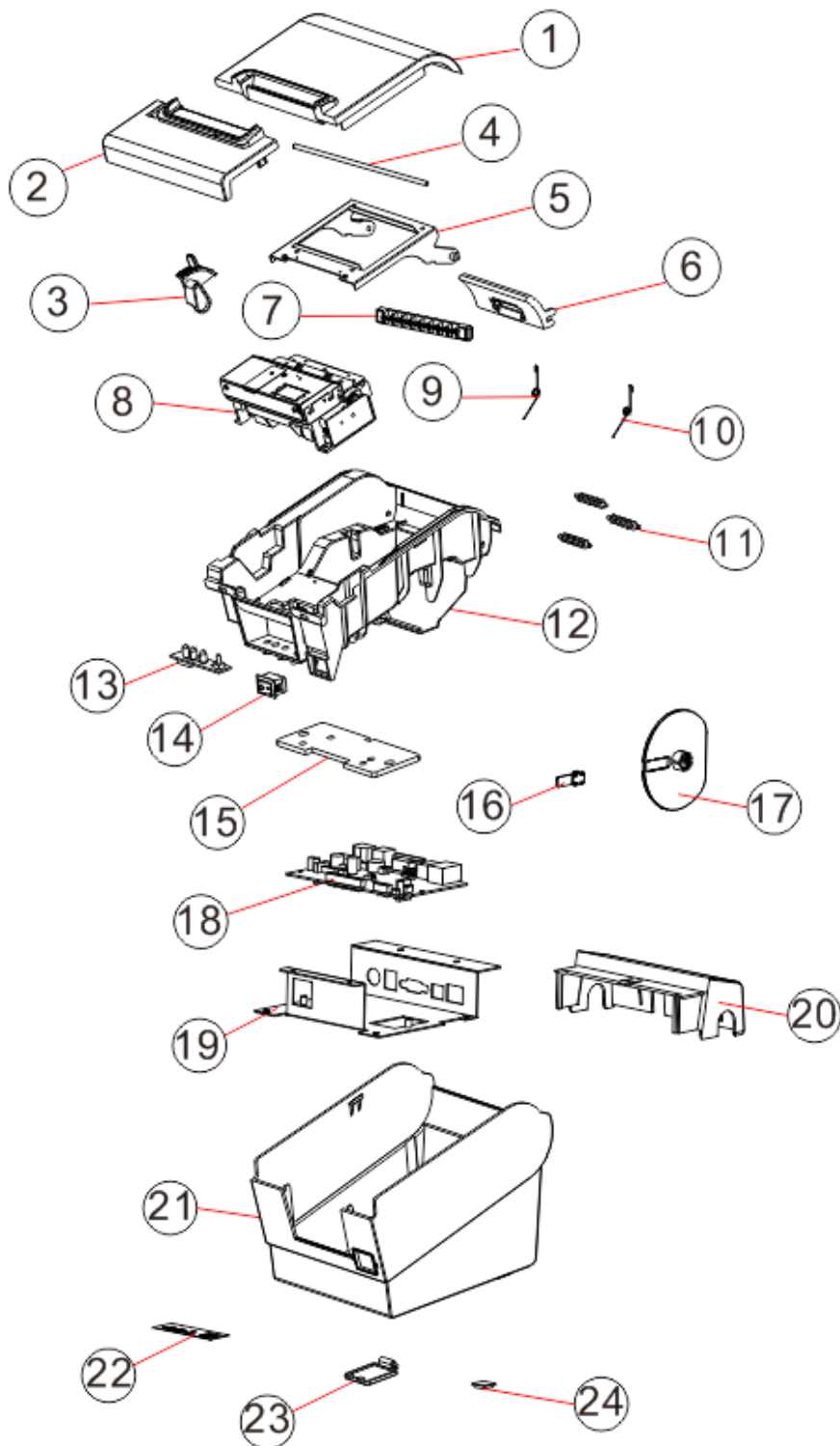

3. Decomposition diagram of printer engine

V1.0

