



TD-2300F / 3000F



TF-100

TF-600

ZigBee Controller (Option)



Battery pack



IR controller (Option)

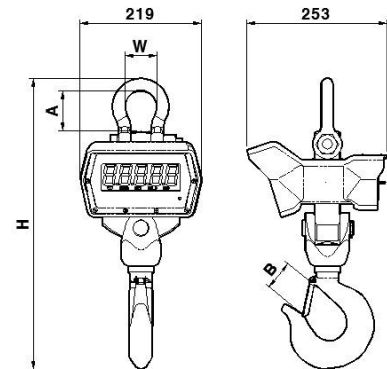

FEATURE

- ◆ Provided swivel hook
- ◆ Big size display
- ◆ Easy to exchange battery pack(Li-Po battery)
- ◆ Infrared Remote controller(Optional)
- ◆ Interface with wireless remote display & controller (Option : ZigBee)

MODEL	DIMMENSION			
	H	A	W	B
TCB-1T	412	62	50	27
TCB-3T	489	73	57	32
TCB-5T	519	73	57	42
TCB-10T	639	101	83	52

MODEL	TCB-1T	TCB-3T	TCB-5T	TCB-10T	TCB-1TL	TCB-3TL	TCB-5TL	TCB-10TL
Capacity	1,000kg	3,000kg	5,000kg	10,000kg	1,000kg	3,000kg	5,000kg	10,000kg
Division	0.5kg	1kg	2kg	5kg	0.5kg	1kg	2kg	5kg
Max. Tare Weight	1,000kg	3,000kg	5,000kg	10,000kg	1,000kg	3,000kg	5,000kg	10,000kg
Product weight	8.2kg	12.0kg	14.5kg	27.1kg	8.2kg	12.0kg	14.5kg	27.1kg
Operating time	Approx.60hr				Approx.200hr (Backlight off)			
Display	5digit, 35mm FND				6 digit, 29mm FSTN LCD			
Battery	Lithium Polymer Battery 7.4V				Lithium Polymer Battery 3.7V			
Charging adaptor	DC 12V, 1A SMPS				DC 5V, 1A SMPS			
Temperature range	-10°C ~ 40°C							
Display lamp	Low Battery, Zero, Tare, Hold							
Keypad	ON/OFF, Zero, Tare, Hold							
Parts	Charging Adaptor , Lithium Polymer Battery Pack							



• www.tmteng.com
 • tmt@tmteng.com
 TMT ENGINEERING CO., LTD.