

MVS SHIPPING SCALE



Features

- **Applications:** Shipping and receiving, warehouse, livestock, general purpose weighing
- **Loadcell:** Single point Alum. load cell, resolution up to 1/7500
- **Construction:** Durable checked steel platform for anti-slip
Heavy duty welded steel supports
With shipping screw protecting load cell against damage during transportation
Equipped with adjustable feet for quick set-up and stability
3m coil cable from base to indicator for durability and easy extension
- **Indicator:** Rugged ABS housing
4 keys: ZERO/ON/OFF, TARE, UNIT, PRINT/HOLD
- **Functions:** Weighing, Tare, Hold, Auto-off function

Specifications

Model	MVS Series		
Capacity	77lbx0.05lb 35kgx0.02kg	165lbx0.1lb 75kgx0.05kg	440lbx0.2lb 200kgx0.1kg
Display resolution	1:1540	1:1650	1:2200
Weighing Units	lb / lb:oz / kg		
Display	0.58" (15mm) 7-segment LCD, 5 1/2 digits		
Zero Range	±20% of full capacity		
Tare Range	Full capacity		
Stabilization time	< 3 seconds		
Operation Temp	40°F to 104°F (5°C to 40°C)		
Humidity range	<90% relative humidity, non-condensing		
Power	Battery: 1x9V battery / AC Adapter: 9V 600mA adapter, central positive		
Interface	USB		
Safe overload	150% of capacity		
Base Dimensions	12" x 12" x 2.44" (L x W x H) 305 x 305 x 62mm (L x W x H)		
Shipping Weight	Net weight.: 8.7 lb (3.9kg) / Gross weight.: 9.7 lb (4.4kg)		

Dimensions (mm/inch)

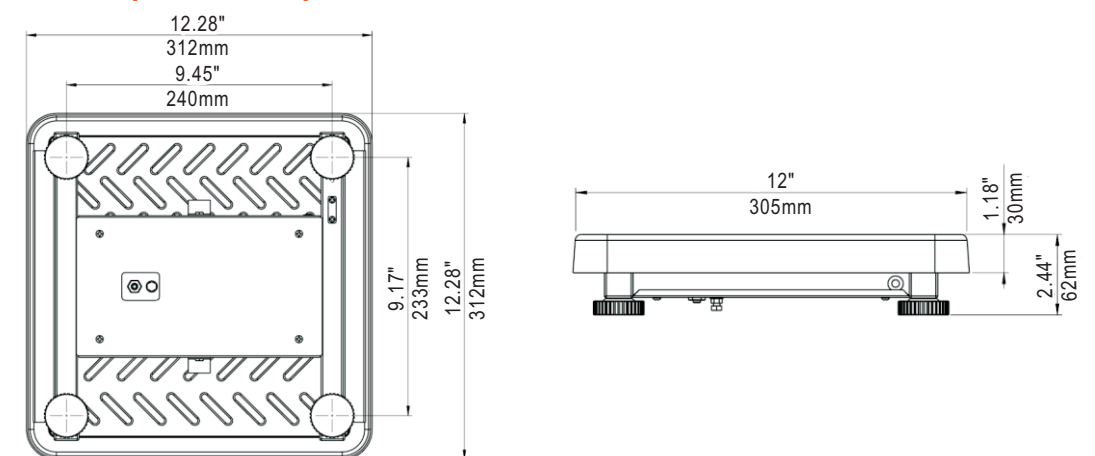

- **LCD with backlight**, clear to see from any angle of view
- 4 keys for easy operation, with HOLD function

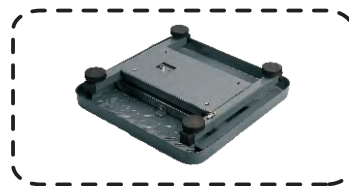

- Heavy duty structure with checked steel platform, equipped with high precision Alum. load cell
- Adjustable feet for quick set up and stability



- USB port, allows to communicate with computer