

# Multi-purpose electronic scale UPGRADED by DESIGN

GL-6000L SERIES



## Portability

Multipurpose electronic scale which is easy to carry

## Display reverse function

check the weight in a forward / reverse direction

## Convenience

Ergonomic handle for convenient carry

## Visibility

Back Light (White) and wide display

## Features

High/low limit and Alarm setting function

GL-6060L

GL-6150L

GL-6300L

GL-6500L

# GL-6000L Series

## Features

### Portability

Multipurpose electronic scale which is easy to carry

### Display reverse function

check the weight in a forward / reverse direction

### Convenience

Ergonomic handle for convenient carry

### Visibility

Back Light (White) and wide display

## Specifications



### Option : DEP-50 Receipt Printer

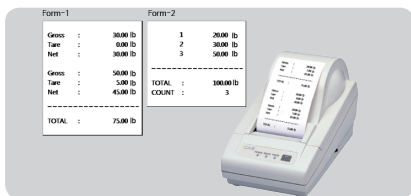

	GL-6060L	GL-6150L	GL-6300L	GL-6500L
Capacity	Dual Interval 30/60 lb	Dual Interval 60/150 lb	Dual Interval 150/300 lb	Dual Interval 250/500 lb
Graduation	0.01/0.02 lbs	0.02/0.05 lbs	0.05/0.1 lbs	0.1/0.2 lbs
External Resolution	1/3000	1/3000	1/3000	1/2500
Internal Resolution	1/60000	1/75000	1/60000	1/50000
MAX Tare	-29.99 lbs	-59.98 lbs	-149.95 lbs	-249.9 lbs
Display	LCD 6 Digit			
LCD	5.1 × 1.8 inch / 130 × 48 (mm) / Large LCD			
LCD Symbol	ZERO, NET, PRINT, O(Stabilization lamp) lb, kg, Battery (3 stage)			
Keys	ZERO, TARE, PRINT, UNIT, ON/OFF : 5 Functions in total			
Sensor	LOAD CELL			
Power	AC Adaptor : (SMPS) Input : 100 V~240 V / 50~60 Hz, Output : DC 6 V / 0.5 A			
Operation Time	Alkaline : about 300 hours, Manganese : about 50 hours			
Operating Temperature	14 °F ~ 104 °F / -10 °C ~ +40 °C			
Interface	RS-232 C			
Platform Size	13.9 (W) × 16.8 (D) inch / 355 (W) × 427(D) mm			
Product Size	13.9 (W) × 23.1(D) × 3.4 (H) inch / 355(W) × 589(D) × 88(H) mm			
Product Weight	about : 15.3 lb / 6.95 kg			
Option	DEP-50 Receipt Printer / Battery C-TYPE (LR14) 1.5V / 4EA			
Warranty	2 years			

## Dimension

### Use to

- Industrial inspection
- Luggage, Courier
- Hospital
- Packing / Meat processing store
- Fitness center, Sauna, House scale
- Agricultural-Fishery products, Dried fish, fruits and vegetables

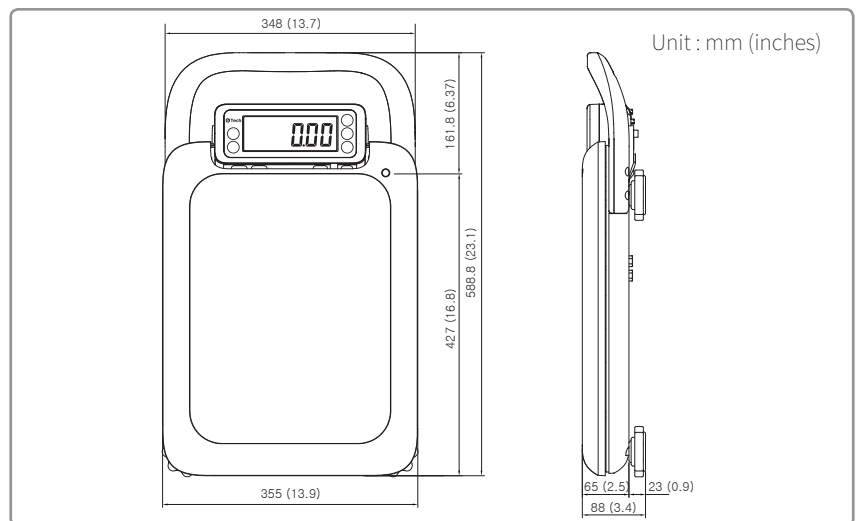

MADE IN KOREA

### USA Branch

[www.VisionTechShop.com](http://www.VisionTechShop.com)

100 Temple Ave. Hackensack, NJ 07601

Tel : + 1-201-679-7793

### Head Office

[www.gtech21.net](http://www.gtech21.net)

Yonghyun Industrial Complex, 29, Sandan-ro 68beon-gil,  
Uijeongbu-si, Gyeonggi-do, Korea 11781

Tel : +82-31-852-4070 Fax : +82-31-852-4656

Distributed by

Ver.1.0