

| | | | | |
|----|-----------|----------|----------|-------|
| Nr | ITEM NAME | MATERIAL | GRADE Nr | MAKER |
| | | | | |

| |
|----------------|
| PITCH: 4.23 MM |
| WIDTH: 2.0 MM |
| URNS: 1 |
| GCM: 53-400 |

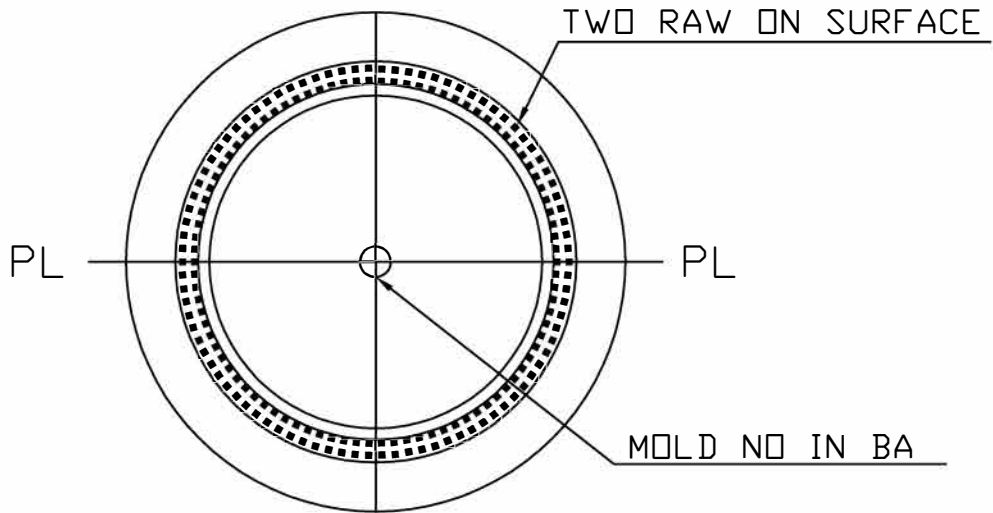
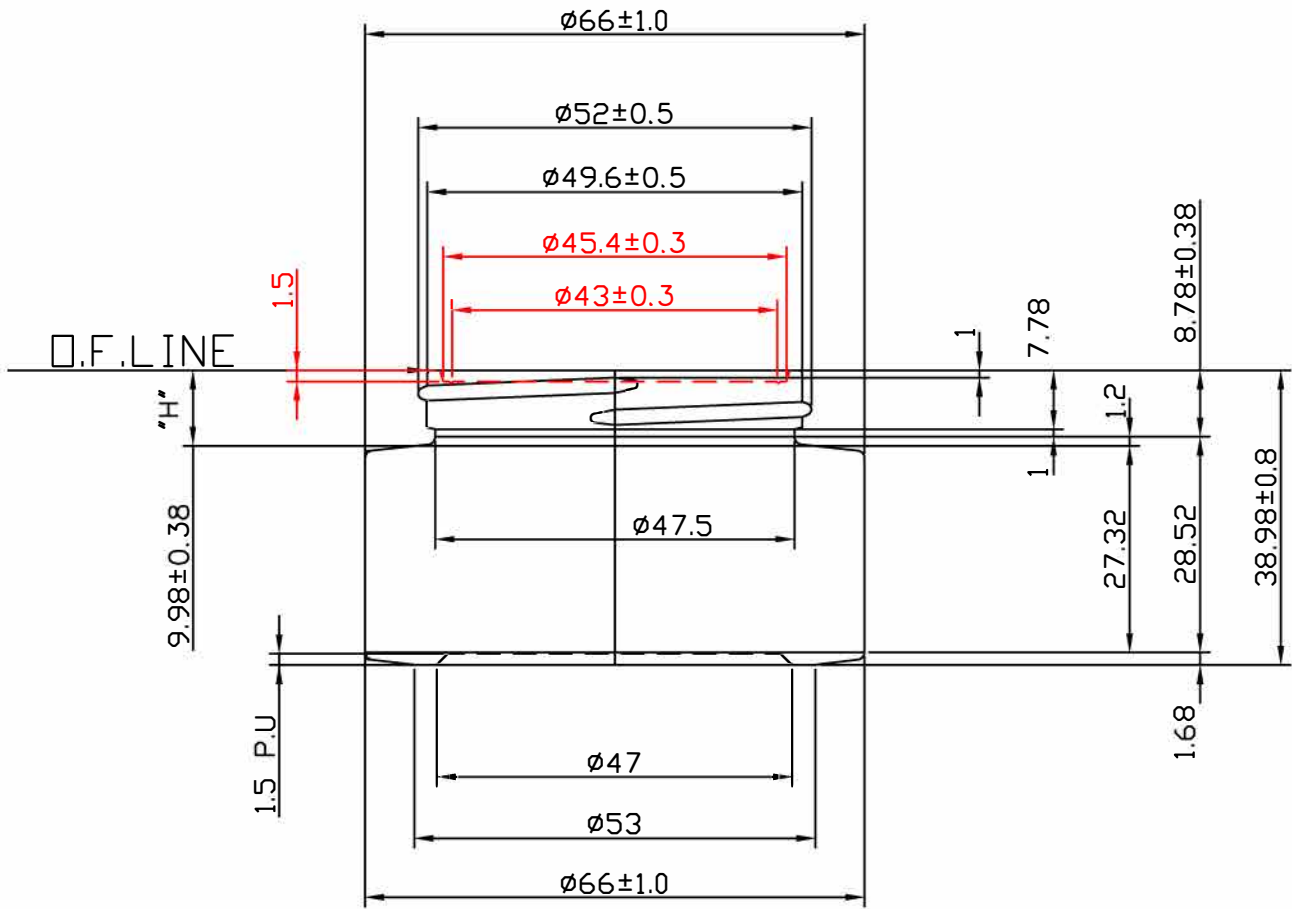

| | | | | | |
|---|-----------------|------------------|-------------------------------------|-----------------|-------------------------|
| 3 | | | | | |
| 2 | | | | | |
| 1 | | | | | |
| Revision: | Description: | | | Date: | Approved: |
| | NAME: DAVID, LU | DATE: 2018/11/19 | | MATERIAL: GLASS | MANUFACTURER CODE C0616 |
| | | | Useful Capacity: | | |
| | | | Overflow Capacity: OF 68.0 ± 3.0 ML | CLIENT: | |
| | | | Weight: 117.0 ± 7.5 GRAMS | | |
| PROJECT NUMBER | DESCRIPTION: | | | DWG NR. REF | |
| | | | | SCALE: 1/1 | instockpack. |
| The copyright of this drawing is owned by Quadpack Group. Its contents shall not be reproduced nor disclosed to a third party without written permission. | | | | SHEET 1 OF 1 | |