

NO	DESCRIPTION	REASON	DATE	CHECK
△				

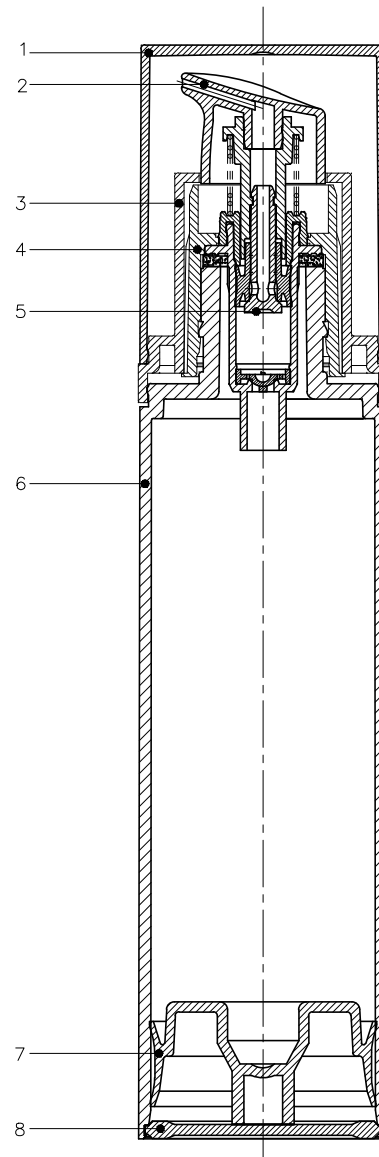
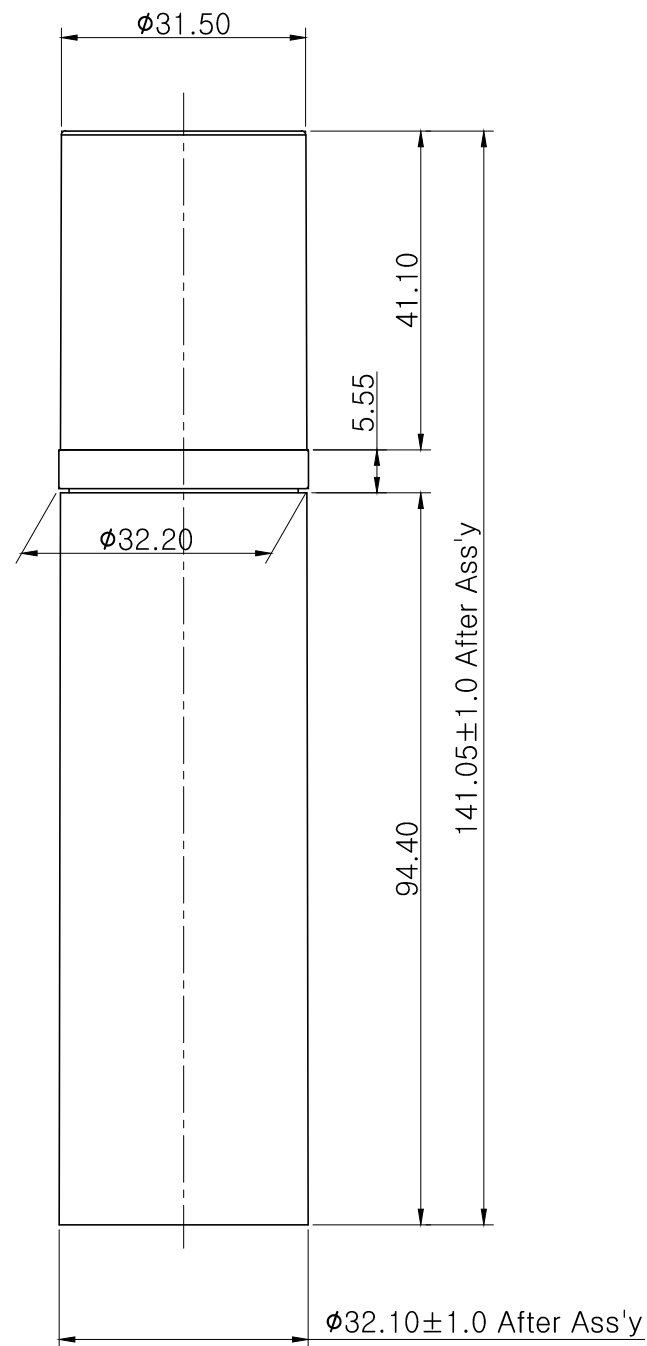
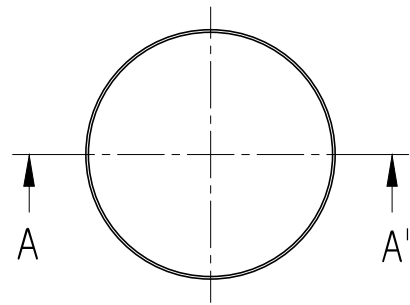

SECTION A-A'

REMARK				
NOTE				
1. LEAKAGE TEST METHOD : VACUUM SUCKING TEST AT -60cmHg FOR 1MIN/WATER				
2. DOSAGE : 0.20ml±0.02ml / STROKE				
3. FILL CAPACITY : 51.00ml±1.0ml(WATER)				
4. O.F.C. : 53.55ml±1.0ml(WATER)				
5. WEIGHT : 32.75g (PART 00.0±5%, ASS'Y 00.0±10%)				
6. General terms and conditions of quality to comply with Yonwoo standard				

NO	ITEM	MAT'L	REMARK	PART NO.
8	BOTTOM	PP	EXISTING MOLD	BT029
7	PISTON	PE	EXISTING MOLD	PT030
6	BOTTLE	PP	EXISTING MOLD	BO096
5	PUMP ASS'Y	-	EXISTING MOLD	-
4	SNAP ON CAP	PP	EXISTING MOLD	SO008
3	PUMP CAP	PP	EXISTING MOLD	PL033
2	ACTUATOR	PP	EXISTING MOLD	BU192
1	OVER CAP	PP	EXISTING MOLD	OC097

TITLE.		AS0050-S/PP FULL ASS'Y		
DWG NO.	Q2181-0	SCALE	1 : 1	 <small>Unspecified Tolerance</small> 0 < 5 - ±0.05 5 < 20 - ±0.10 20 < 40 - ±0.20 40 < 80 - ±0.30 80 < 160 - ±0.40 160 < 320 - ±0.50 Angular - ±0.5°
Drawn by	Checked by	Checked by	Approved by	
Kim, Joo Young				MAT'L REF. TABLE DATE 2018.11.06 DECIMALS UNIT: mm