

NO	DESCRIPTION	REASON	DATE	CHECK
△				

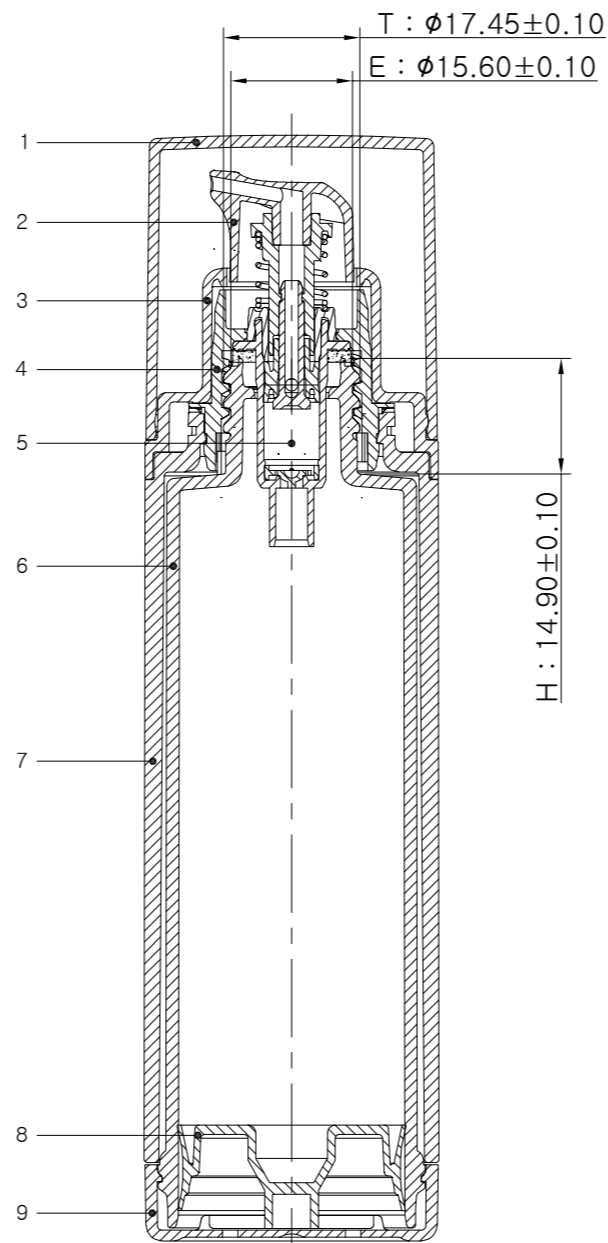
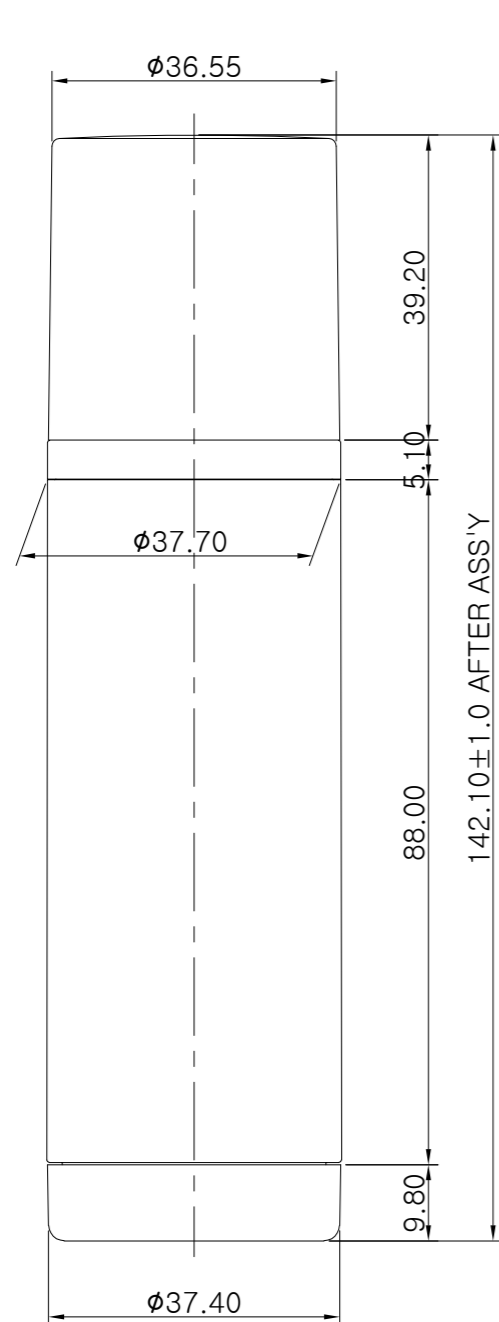
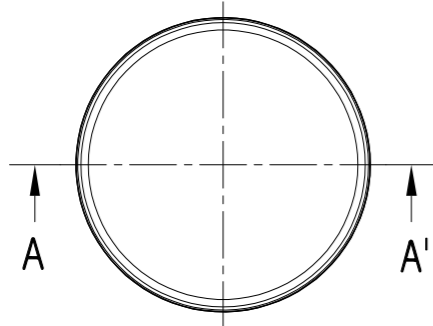

SECTION A-A'

REMARK				
NOTE				
1. LEAKAGE TEST METHOD : VACUUM SUCKING TEST AT -60cmHg FOR 1MIN/WATER				
2. DOSAGE: 0.20ml ± 0.02ml / STROKE				
3. FILL CAPACITY: 51.00ml ± 1.0ml(WATER)				
4. O.F.C.: 56.40ml ± 1.0ml(WATER)				
5. WEIGHT : 69.25g (PART 00.0±5%, ASS'Y 00.0±10%)				
6. General terms and conditions of quality to comply with Yonwoo standard				
9	BOTTOM	PP	EXISTING MOLD	BT188
8	PISTON	PE	EXISTING MOLD	PT016
7	OUTER BOTTLE	PETG	EXISTING MOLD	BOB45
6	INNER BOTTLE	PP	EXISTING MOLD	BOB46
5	PUMP ASS'Y	-	EXISTING MOLD	-
4	SCREW CAP	PP	EXISTING MOLD	SC305
3	SHOULDER	ABS	EXISTING MOLD	PL476
2	ACTUATOR	PP	EXISTING MOLD	BU343
1	OVER CAP	PETG	EXISTING MOLD	OCC74
NO	ITEM	MAT'L	REMARK	PART NO.

TITLE.		AS0050-DUL-CC FULL ASS'Y		
DWG NO.	Q2547-0	SCALE	1 : 1	
Drawn by	Checked by	Checked by	Approved by	
Jung, Woo Jae				Unspecified Tolerance 0 < 5 - ±0.05 5 < 20 - ±0.10 20 < 40 - ±0.20 40 < 80 - ±0.30 80 < 160 - ±0.40 160 < 320 - ±0.50 Angular - ±0.5°
DATE	2021.01.07	DECIMALS UNIT:	mm	