

Nr	ITEM NAME	MATERIAL	GRADE Nr	MAKER

PIITCH: 4.23 MM
WIDTH: 2.0 MM
URNS: 1
GCM: 48-400

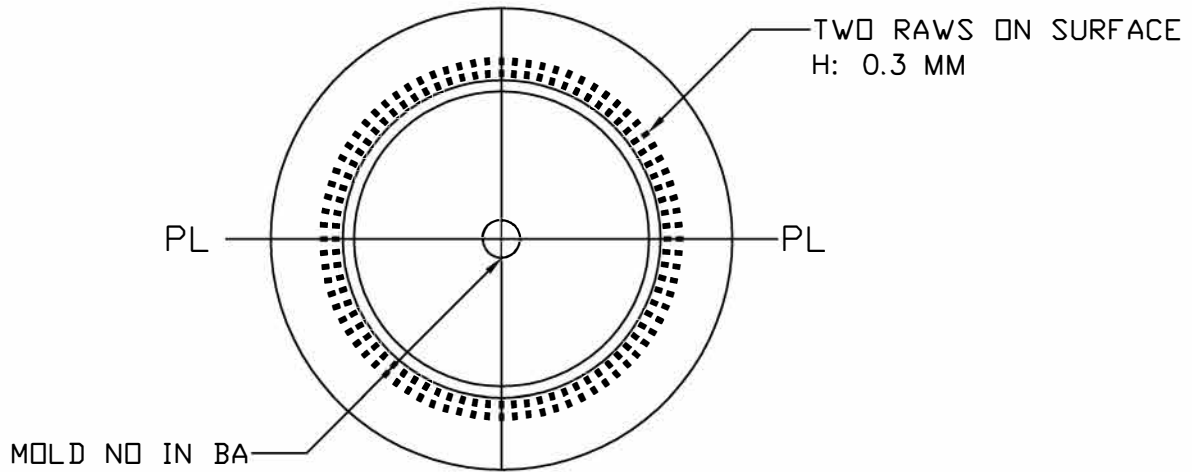
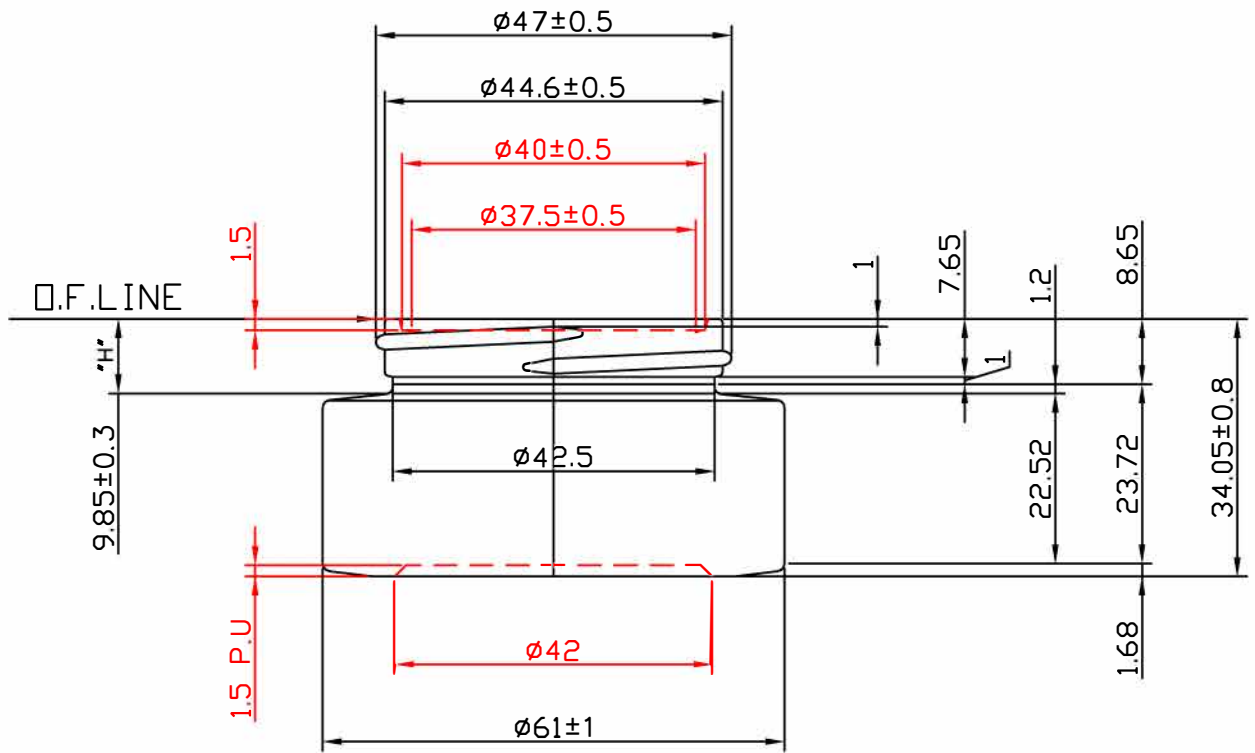

3				
2				
1				
Revision:	Description:		Date:	Approved:
Drawn:	NAME: DAVID, LU	DATE: 2018/11/19	MATERIAL: GLASS	MANUFACTURER CODE C0365
Checked:	-	dd/mm/aa	Useful Capacity:	
Approved:	-	dd/mm/aa	Overflow Capacity: OF 37±2 ML	CLIENT:
PROJECT NUMBER	DESCRIPTION:		Weight: APPROX 112.5 G	
		DWG NR.	REF	
The copyright of this drawing is owned by Quadpack Group. Its contents shall not be reproduced nor disclosed to a third party without written permission.		SCALE: 1/1		
		SHEET 1 OF 1		