

NO	DESCRIPTION	REVISION	DATE	CHECK
△				

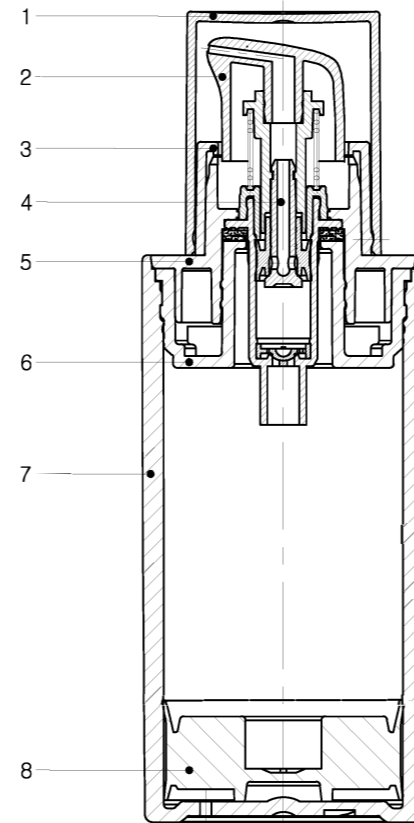
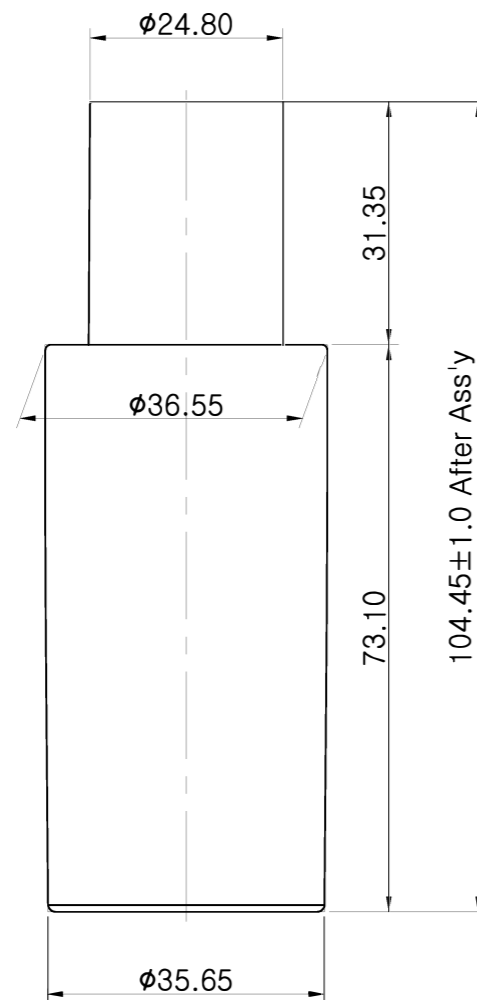
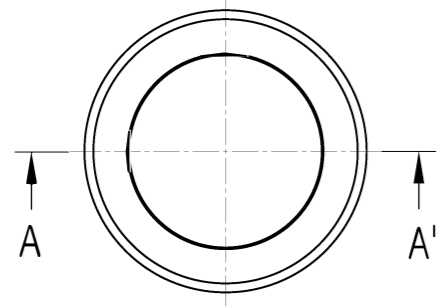

SECTION A-A'

REMARK

NOTE

1. LEAKAGE TEST METHOD : VACUUM SUCKING TEST AT -60cmHg FOR 1MIN/WATER
2. DOSAGE: 0.20ml± 0.02ml / STROKE
3. FILL CAPACITY: 31.00ml±1.0ml(WATER)
4. O.F.C.: 45.80ml±1.0ml(WATER)
5. WEIGHT : 35.10g (PART 00.0±5%, ASS'Y 00.0±10%)
6. General terms and conditions of quality to comply with Yonwoo standard

NO	ITEM	MAT'L	REMARK	PART NO.
8	PISTON	PE	EXISTING MOLD	PT147
7	BOTTLE	PP	EXISTING MOLD	BO878
6	HOUSING	PP	EXISTING MOLD	HU156
5	SHOULDER CAP	PP	EXISTING MOLD	PL333
4	PUMP ASS'Y	-	EXISTING MOLD	-
3	COLLAR	PP	EXISTING MOLD	PL287
2	ACTUATOR	PP	EXISTING MOLD	BU323
1	OVER CAP	PETG	EXISTING MOLD	OC294

TITLE. AS0030-PN FULL ASS'Y

DWG NO. Q2194-0 SCALE 1 : 1

Drawn by Bong, Hun Checked by [] Approved by [] MAT'L REF.TABLE

DATE 2018.11.27

Engineering 2018.11.27 BongHun

Unspecified Tolerance
 0 < 5 - ±0.05
 5 < 20 - ±0.10
 20 < 40 - ±0.20
 40 < 80 - ±0.30
 80 < 160 - ±0.40
 160 < 320 - ±0.50
 Angular - ±0.5°

DECIMALS UNIT: mm

instockpack.