

NO	DESCRIPTION	REASON	DATE	CHECK
⚠				

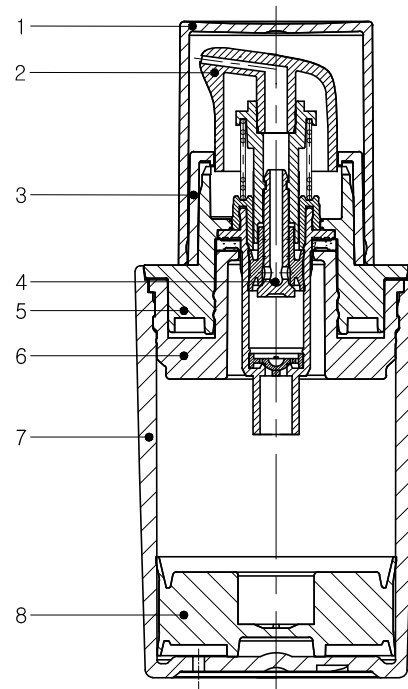
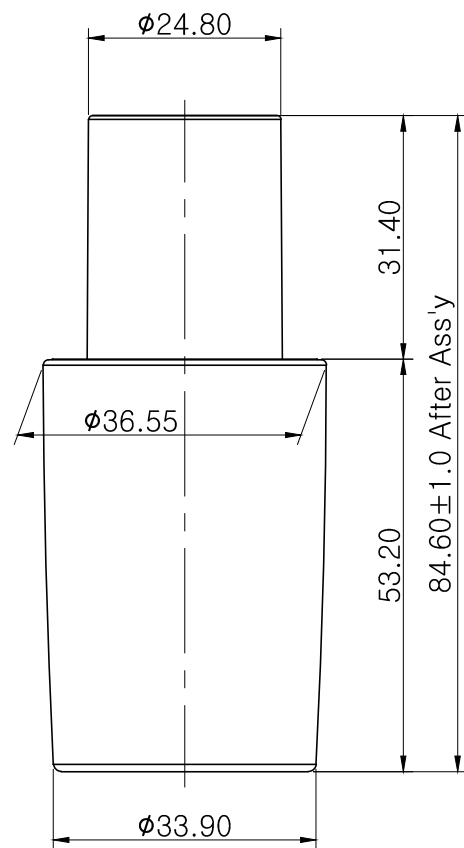
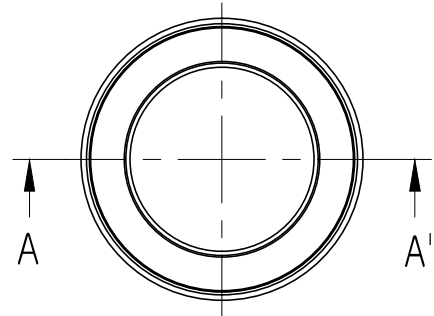

SECTION A-A'

REMARK

NOTE

- LEAKAGE TEST METHOD : VACUUM SUCKING TEST AT -60cmHg FOR 1MIN/WATER
- DOSAGE: 0.20ml ± 0.02ml / STROKE
- FILL CAPACITY: 16.00ml ± 1.0ml (WATER)
- O.F.C.: 30.00ml ± 1.0ml (WATER)
- WEIGHT : 31.09g (PART 00.0±5%, ASS'Y 00.0±10%)
- General terms and conditions of quality to comply with Yonwoo standard

8	PISTON	PE	EXISTING MOLD	PT147
7	BOTTLE	PP	EXISTING MOLD	BO877
6	POINT NECK HOUSING	PP	EXISTING MOLD	HU156
5	SHOULDER CAP	PP	EXISTING MOLD	PL333
4	PUMP ASS'Y	-	EXISTING MOLD	-
3	COLLAR	PP	EXISTING MOLD	PL287
2	ACTUATOR	PP	EXISTING MOLD	BU323
1	OVER CAP	PETG	EXISTING MOLD	OC294
NO	ITEM	MAT'L	REMARK	PART NO.

TITLE.		AS0015-PN FULL ASS'Y		
DWG NO.	Q2193-0	SCALE	1 : 1	<small>Unspecified Tolerance</small> 0 < 5 - +0.05 5 < 20 - +0.10 20 < 40 - +0.20 40 < 80 - +0.30 80 < 160 - +0.40 160 < 320 - +0.50 Angular - +0.5°
Drawn by	Checked by	Checked by	Approved by	
Bong, Hun				MAT'L REF. TABLE DATE 2018.11.27 DECIMALS UNIT: mm
			Engineering 2018.11.27 BongHun	instockpack.