

POS-NR.	Description	Finished	Material	Weight	Quantity
1	Jar 100ml	Glossy	PP	45,5g	1
2	Cap for 100ml	Glossy	PP	11,12g	1
3	Liner 63,5 x 2mm		Alveolit		1

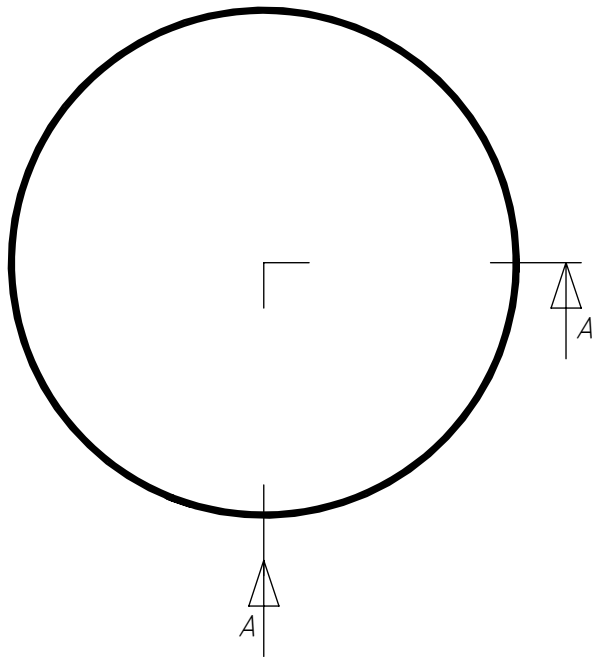
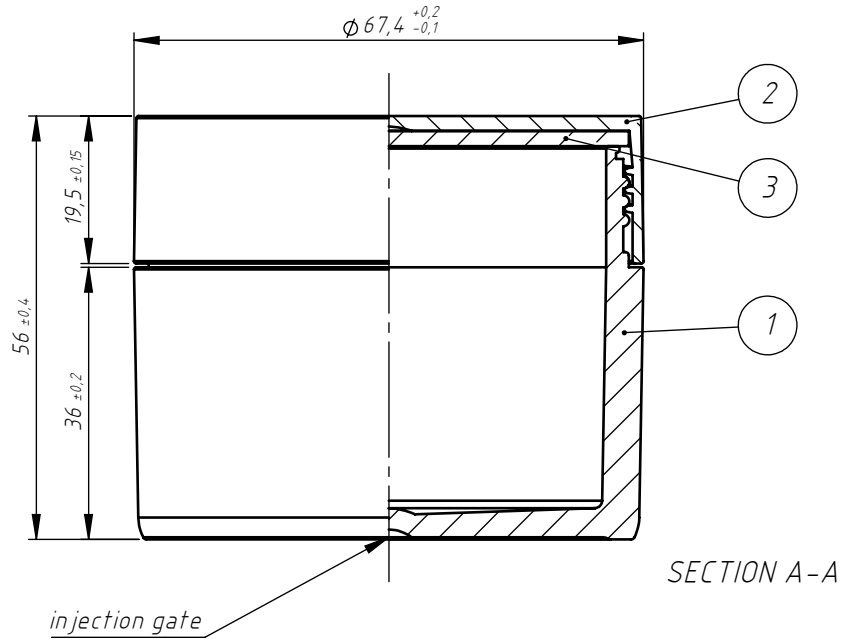

COMERCIAL DRAWING

A		Create drawing		17/03/2022		D. Lindenthal							
Version:		Description:		Date:		Made by:							
NAME:		DATE:		GENERAL TOLERANCES				CLIENT:					
Drawn:		17.03.2022		SCALE: 1:1		0 - 10		± 0.15		40 - 60		± 0.5	
Checked:		-		O.F.C.: 122 ± 3ml		10 - 20		± 0.25		60 - 80		± 0.8	
Approved:		-		NOM. CAP.: 100ml		20 - 40		± 0.35		> 80		± 1	

DRAWING Nr.
QPLQL_00_0160_a

DESCRIPTION:
Jar Regula 100ml



The copyright © of this drawing is owned by Quadpack Group.
Its contents shall not be reproduced nor disclosed to a third party without written permission.

