

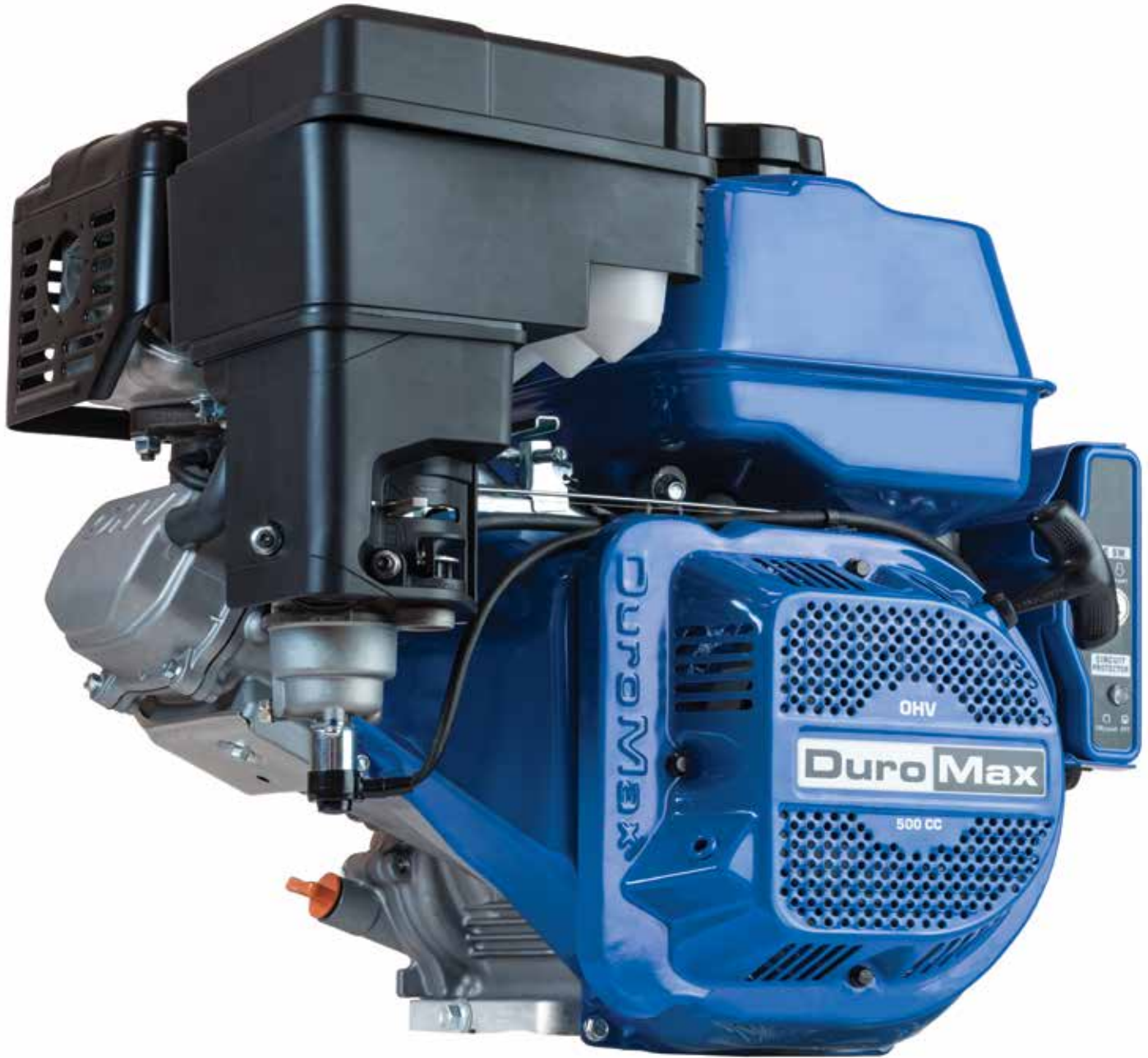

XP20HPE

S E R V I C E M A N U A L



REV: XP20HPE_rev12152022

This manual provides information regarding the operation and maintenance of these products. We have made every effort to ensure the accuracy of the information in this manual. We reserve the right to change this product at any time without prior notice.

5800 Ontario Mills Pkwy
Ontario, CA 91764 USA
www.duromaxpower.com
Call our Customer Care Team Toll Free 8-5pm PST Mon-Fri
844-DUROMAX



CONTENTS

1.

Maintenance and Care

Maintenance Schedule.....	4
Break-In Period	5
High Altitude Operation	5
Checking the Oil	6
Changing the Oil.....	7
Changing the Air Filter.....	8
Spark Plug Maintenance	10
Emptying the Gas Tank	12
Storing the Engine for Same Day Use	14
Storing the Engine for Use Within 30 Days.....	15
Storing the Engine for Longer Than 30 Days.....	16

2.

Common Engine Parts

Common Engine Parts.....	18
--------------------------	----

3.

Specifications

Specifications.....	23
Adjustment and Torque Value Specifications	24
Engine Diagrams	25
Wiring Diagram	27

4.

Troubleshooting

Troubleshooting.....	28
----------------------	----

5.

Maintenance Log

Maintenance Log.....	29
----------------------	----

MAINTENANCE AND CARE

Proper routine maintenance of your engine is essential for safe, economical, and trouble-free operation. It will also help reduce air pollution.



WARNING: Improper maintenance, or failure to correct a problem before operation, can cause a malfunction in which you can be seriously injured or killed. Always follow the inspection, maintenance recommendations, and schedules in this instruction manual.

- Make sure the engine is off before you begin any maintenance or repairs.
- Let the engine and exhaust system cool before touching.
- To reduce the possibility of fire or explosion, be careful when working around gasoline. Use only a nonflammable solvent, not gasoline, to clean parts. Keep cigarettes, sparks, and flames away from all fuel-related parts.

Maintenance Schedule

Remember that this schedule is based on the assumption that your machine will be used for its designed purpose. Sustained high-load, high-temperature operation, or use in unusually wet or dusty conditions, will require more frequent service.

SERVICE	EVERY USE	1ST MO. OR 8 HRS. (BREAK IN)	EVERY 3 MO. OR 50 HRS. OF HEAVY USE	EVERY 6 MO. OR 100 HRS. OF NORMAL USE	EVERY 12 MO. OR 300 HRS.	EVERY 3 YRS. OR 500 HRS.
ENGINE OIL	CHECK	CHANGE	CHANGE	CHANGE		
AIR CLEANER	CHECK	CHECK	CHANGE	CHANGE		
SPARK PLUG			CLEAN / ADJUST	CLEAN / ADJUST		
SPARK ARRESTOR	CHECK				CLEAN	
IDLE SPEED					CHECK / ADJUST	
VALVE CLEARANCE					CHECK / ADJUST	
FUEL TUBE	CHECK				CHECK / REPLACE	
FUEL TANK / FILTER					CLEAN	
COMBUSTION CHAMBER						CLEAN

Break-In Period

As the best practice for any new combustion motor it's recommended to perform the break in procedure as follows:

- Run the engine for the first 6-8 hours on conventional oil, then change the oil. After the break-in period synthetic oil may be used.
- During the break in period of the first 6-8 hours keep the engine speed under 50% for optimal results.
- Check and clean the air filter if necessary after the break-in period.

High Altitude Operation

At high altitudes, the standard carburetor air/fuel mixture will be too rich. The performance will decrease, and fuel consumption will increase. A very rich mixture will also foul the spark plug and cause hard starting. Operation at an altitude that differs from that at which this engine was certified, for extended periods of time, may increase emissions. High altitude performance can be improved by specific modifications to the carburetor. If you always operate your engine at altitudes above 3,000 feet (900 meters), have a dealer perform this carburetor modification. This engine, when operated at high altitude with the carburetor modifications for high altitude use, will meet each emission standard throughout its useful life. Even with carburetor modification, engine horsepower will decrease by about 3.5% for each 1,000-foot (300-meter) increase in altitude. The effect of altitude on horsepower will be greater than this if no carburetor modification is made.

When the carburetor has been modified for high altitude operation, the air/fuel mixture will be too lean for low altitude use. Operation at altitudes below 3,000 feet (900 meters) with a modified carburetor may cause the engine to overheat and result in serious engine damage.

Note: Jet kits available for purchase upon request, please contact us at 844-DUROMAX to set up your parts order.

Checking the Oil



Check the oil

The engine is equipped with an automatic shutoff to protect it from damage due to low oil. Nonetheless, you should check the oil level of the engine before each use to ensure that the engine crankcase has a sufficient amount.

To check the oil level:

- a. Make sure the engine is on a level surface.
- b. Unscrew the oil filler/dipstick cap.
- c. With a dry cloth, wipe the oil off of the stick on the inside of the cap.
- d. Insert the dipstick as if you were replacing the cap and then remove it again. There should now be oil on the stick. If there is no oil on the stick, or oil only at the very end of the stick, you should add oil until the engine crankcase is filled (see “Adding Oil” portion of the “Maintenance” section).
- e. The oil will be visible in the oil fill spout when full.
- f. Be sure to replace the cap when finished checking oil.



Model Number	XP20HPE
Engine Oil Capacity	40.5 fl. oz (1.2 L)

Changing the Oil



CAUTION: Worn out or dirty oil does not cool the engine properly and can lead to catastrophic engine damage.

In addition to regular oil changes, it is necessary to drain the oil from the crankcase if it has become contaminated with water or dirt.



1. Remove drain plug

Using a 12 mm hex wrench, unscrew the oil drain plug, which is located on the crankcase underneath the oil filler/dipstick cap.

Allow all the oil to drain from the engine.



2. Drain oil

Drain oil into an approved oil disposal container. Contact your local auto parts store for information on oil disposal.



3. Replace drain plug

Replace the oil drain plug and tighten with a 12 mm hex wrench.

MAINTENANCE AND CARE (CONTINUED)

Changing the Air Filter

MAINTAIN AIR FILTER

Clean air filter after every 50 hours of use
(every 10 hours in unusually dusty conditions)

Wash filter element with household detergents.
Wipe out dust from air filter housing before
replacing filter element.

Never clean with a brush

Routine maintenance of the air cleaner helps maintain proper airflow to the carburetor. Check that the air cleaner is free of excessive dirt after every use.



CAUTION: Improper maintenance may cause less air to enter the engine or dirty air to enter the engine causing overheating and engine wear.



1. Remove filter cover wing nut

Remove the top screw located on the top of the air filter cover.



2. Remove filter cover

Remove the plastic air filter cover by lifting the cover upwards to expose the air filter element.



3. Remove old filter element

Remove the wing nut on top of the air filter element and slide filter element off center bolt. This filter is paper and is not reusable. Please call 1-844-DUROMAX to order a replacement filter for your engine.



4. Replace new filter element

Slide new filter element over center bolt, and replace wing nut. Tighten wing nut hand tight to keep filter in place.

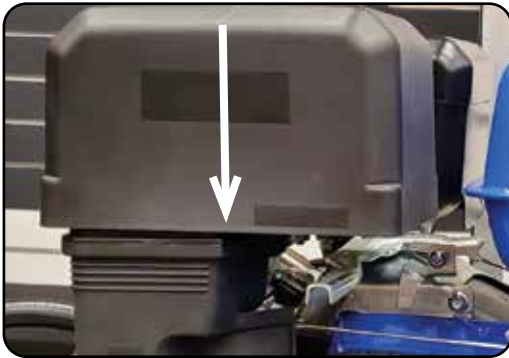

5. Replace filter cover

Replace plastic air filter cover over the air filter base.



6. Secure filter cover

Fasten the air filter cover with the air filter cover wing nut and tighten about hand tight.

MAINTENANCE AND CARE (CONTINUED)

Spark Plug Maintenance



The spark plug is important for proper engine operation. A good spark plug should be intact, free of deposits, and properly gapped.



CAUTION: Improper maintenance may cause reduced fuel economy, misfires, trouble starting, or damage to the spark plug threads.



1. Remove spark plug cap

Pull on the spark plug cap to remove it.



2. Remove spark plug

Unscrew the spark plug from the engine using the spark plug wrench included with this product.



3. Inspect spark plug

Visually inspect the spark plug. If it is cracked or chipped, discard and replace it with a new spark plug. We recommend using an F6TC spark plug such as NGK BP6ES.



4. Measure plug gap

Measure the plug gap with a gauge. The gap should be 0.7-0.8 mm (0.028-0.031 in).



5. Clean and re-gap

If you are re-using the spark plug, use a wire brush to clean any dirt from around the spark plug base and then re-gap the spark plug.



6. Install spark plug

Screw the spark plug back into its place on the engine using the spark plug wrench.



7. Replace spark plug cap

Replace the spark plug cap.

Emptying the Gas Tank



If you have been using gasoline in your engine, before storing your engine for extended periods of time you should drain your engine fuel tank of gasoline.



CAUTION: Do not store fuel from one season to another. Gasoline sold at the pump today contains additives such as ethanol that even when stored properly may damage the fuel system components.

1. Shut fuel valve OFF

Turn the fuel valve to the "OFF" position.



2. Remove carburetor drain bolt

Remove the outward angled bolt that is located on the bottom of the carburetor.



3. Place funnel below drain port

Place funnel with container to catch the gasoline under the drain port location.



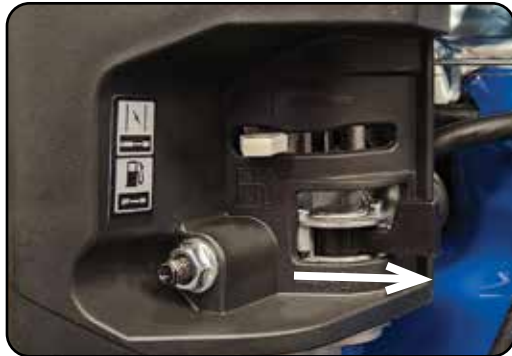

4. Turn fuel valve ON and drain

Turn the fuel valve to “ON” and allow gasoline to drain into the container until the gas tank is empty.



5. Shut fuel valve OFF

Once the gasoline is fully drained, move the fuel valve back to the “OFF” position.



6. Replace carburetor drain bolt

Reinstall the carburetor drain bolt.



7. Store emptied gasoline

Store the emptied gasoline in a suitable place and add fuel stabilizer to keep fuel fresh and usable.

MAINTENANCE AND CARE (CONTINUED)

Storing the Engine for Same Day Use



1. Run the engine

Allow the engine to run for 3-5 minutes.



2. Turn key switch to OFF

Move the key switch to the "OFF" position to shut the engine off.



3. Store engine

After the engine shuts off and cools, then you can store the engine.



CAUTION: Do not obstruct any ventilation openings and keep the engine in a cool dry area.

Storing the Engine for Use Within 30 Days



1. Run the engine

Allow the engine to run for 3-5 minutes.



2. Shut fuel valve OFF and run dry

Shut the fuel valve "OFF" and allow engine to run until it stalls out.



3. Turn the key switch OFF

Move the key switch to the "OFF" position to shut the engine off.



4. Add fuel stabilizer and store

Add fuel stabilizer to gas remaining in tank, and store the engine.

Storing the Engine for Longer Than 30 Days



1. Run the engine

Allow the engine to run for 3-5 minutes.



2. Shut fuel valve OFF and run dry

Shut the fuel valve "OFF" and allow engine to run until it stalls out.



3. Turn the key switch OFF

Move the key switch to the "OFF" position to shut the engine off.



4. Empty the gas tank

Fully drain your gas tank as shown in "Emptying the Gas Tank" on page 12-13.



5. Remove spark plug

Remove spark plug as shown in “Spark Plug Maintenance” on page 10.



6. Add oil to cylinder

Add 2 tablespoons of 10W-30 motor oil directly into the spark plug hole, and pull the recoil to lubricate cylinder. After lubricating cylinder reinstall the spark plug as shown in “Spark Plug Maintenance” on page 11.



7. Store engine

The engine is ready to be stored in a cool dry area.



CAUTION: Do not obstruct any ventilation openings and keep the engine in a cool dry area.

COMMON ENGINE PARTS

Common Engine Parts

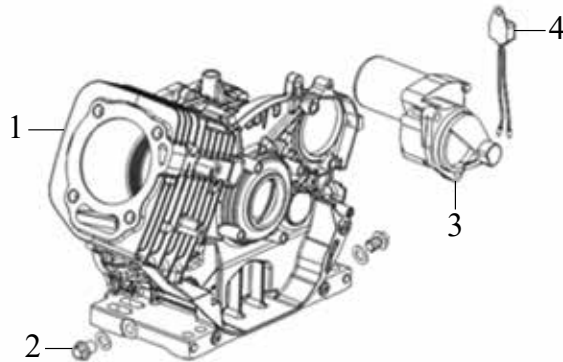

1. Crankcase	11310-Z0D0710-0BA0
2. Oil Drain Bolt	11007-Z080110-00A0
3. Starting Motor	09100-Z170510-00A0
4. Oil Protector	37050-Z010210-0000

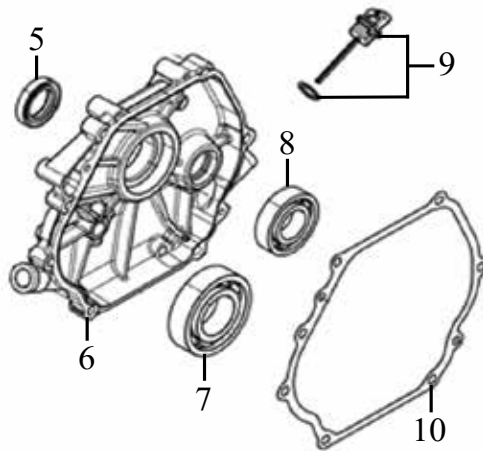

5. Oil Seal	90682-Z0J0110-00A0
6. Crankcase Cover	11411-Z0D0510-0BA0
7. Crankshaft Bearing	90547-0208-CLAE
8. Bearing	90548-0202-CLA0
9. Oil Fill Cap/Dipstick	15010-Z080130-Q500
10. Crankcase Cover Gasket	11001-Z0D0110-00A0

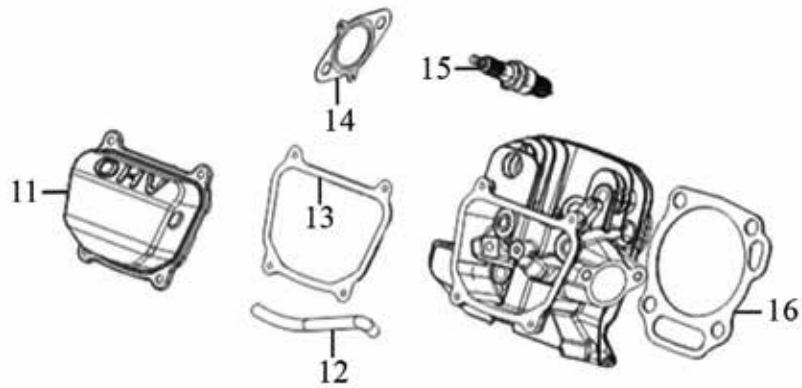

11. Valve Cover	12410-Z0D0210-0BA0
12. Breather Tube	17004-Z0D0410-00A0
13. Valve Cover Gasket	12004-Z0D0211-00A0
14. Muffler/Cylinder Head Gasket	18101-Z0D0110-00A0
15. Spark Plug	30010-Z010210-00A0
16. Cylinder Head Gasket	12131-Z0D0310-00A0

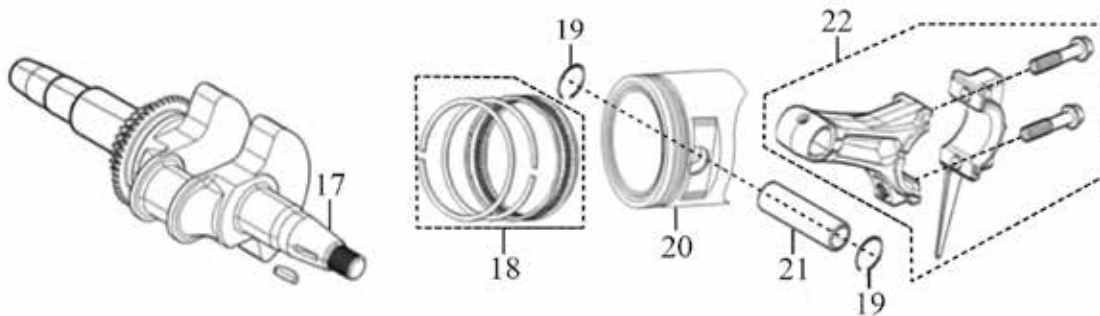

17. Crankshaft Assembly	13300-Z0D0210-CLTM
18. Piston Rings	13200-Z0D0110-00A9
19. Pin Clip	13122-Z100110-00A0
20. Piston	13111-Z0D0211-00A0
21. Pin	13121-Z1X0110-0000
22. Connecting Rod	13010-Z0D0311-00A0

COMMON ENGINE PARTS (CONTINUED)

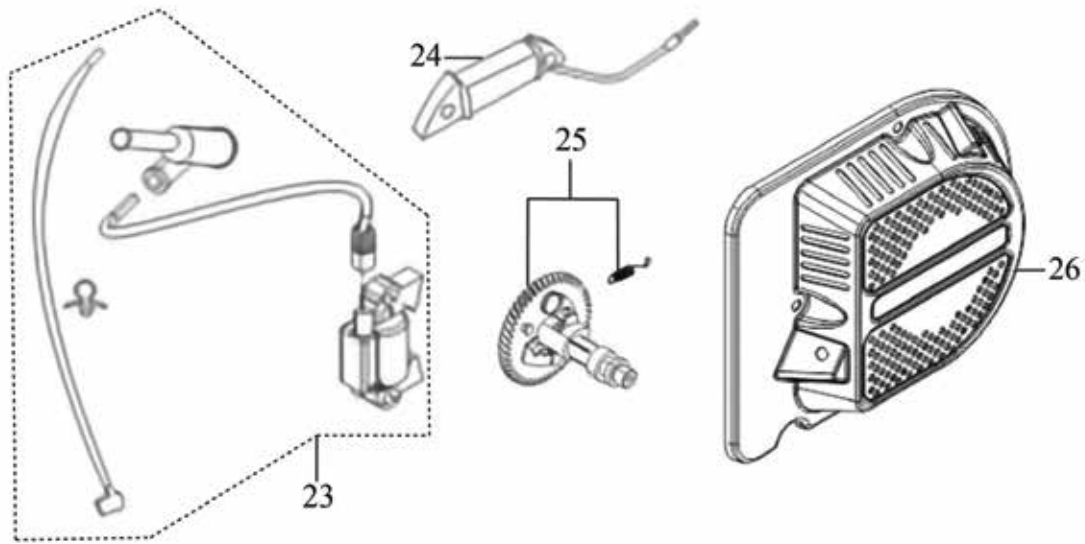

23. Ignition Coil Assembly	30400-Z190210-0000
24. Charging Coil Assembly	30140-Z160130-0000
25. Camshaft Assembly	14200-Z0D0410-00A0
26. Recoil Assembly	28200-Z710110-BG00

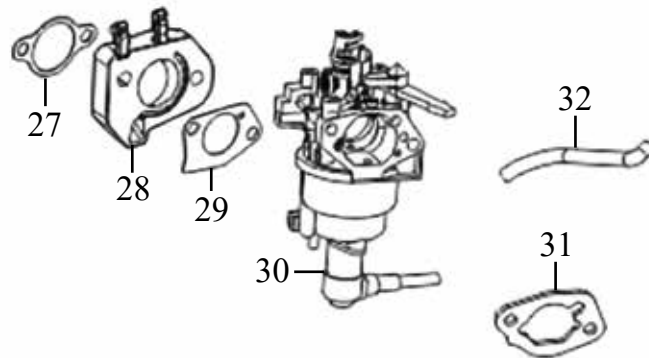

27. Spacer/Cylinder Gasket	17002-Z0D0210-00A0
28. Carburetor Spacer	16003-Z0D0210-00A0
29. Spacer/Carburetor Gasket	16001-Z100110-00A0
30. Carburetor Assembly	16100-Z0D1210-00M0
31. Carburetor/Air Filter Gasket	17001-Z0D0110-00A0
32. Gasoline Fuel Line	90686-Z520110-00M2

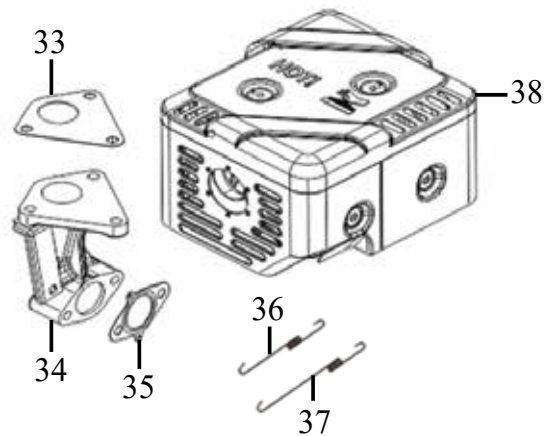

33. Muffler Gasket	18101-Z0D0210-00A0
34. Manifold	18150-Z0D0610-00A0
35. Muffler/Cylinder Head Gasket	18101-Z0D0110-00A0
36. Governor Spring	16063-Z0D0510-00A0
37. Throttle Return Spring	16012-Z0D0110-00A0
38. Muffler Assembly	18100-Z0D0110-00A0

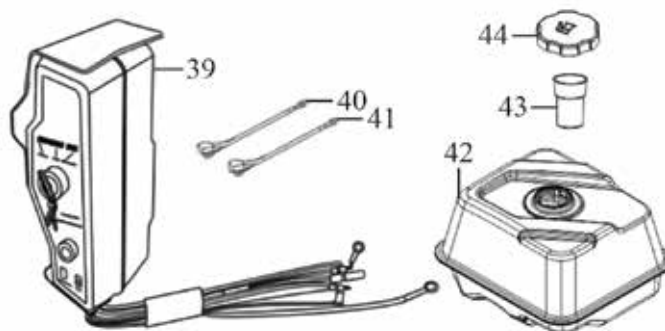

39. Key Switch Assembly	35000-Z160610-BG00
40. Positive Battery Cable	31114HY5R0110-0000
41. Negative Battery Cable	31112HY130410-0000
42. Fuel Tank	16620-Z0D0210-BGA0
43. Fuel Filter	16652-Z010910-00A0
44. Fuel Tank Cap	16730-Z310310-00A0

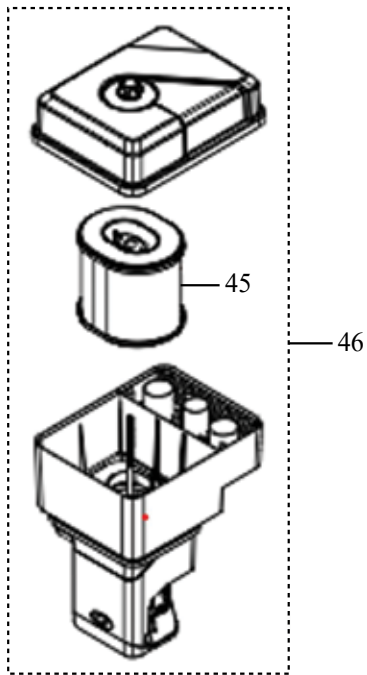

45. Air Filter Element

17150-Z710110-00A0

46. Air Filter Assembly

17100-Z0D0510-00A0

SPECIFICATIONS

Displacement	500cc	
Fuel Type	≥87 octane, ≤10% ethanol, unleaded gasoline	
Dry Weight	83 lbs	
Maximum Torque	22.87 ft. lb @ 2500 rpm	
Compression Ratio	8.5:1	
Bore X Stroke	94 mm x 72 mm	
Engine Oil Capacity	40.5 oz. (1.2 L)	
Fuel Tank Capacity	1.35 gal. (5.1 L)	
Lowest Idling Speed	2100 rpm ± 200 rpm	
Dimensions	LENGTH	21.5 in.
	WIDTH	17 in.
	HEIGHT	19 in.
Engine Type	4-Stroke OHV Forced-Air	
Ignition System	Non-contact transistor	
Lubrication Mode	Splash	
Starting Type	Electric / Recoil	
Shaft Rotation	Counter-clockwise	
Shaft Size	1" diameter, 3.535" long, 1/4" keyway	
Shaft End	3/8" size 24 UNF - 2B drilled and tapped	
Center of Shaft to Base	5.26"	
Bearing Type	Stainless steel ball bearing	
Cylinder Sleeve Type	Cast iron sleeve	
Fuel Delivery System	Carburetor	

SPECIFICATIONS (CONTINUED)

Adjustment and Torque Value Specifications

Adjustment Specification

Spark Plug Clearance	.027-.031 in. (0.7-0.8 mm)
Spark Plug Type	F6TC (Torch), BP6ES (NGK), RN9YC (Champion), W7DC (Bosch), W20EP-U (Denso)
Valve Clearance (Cold)	Intake: .00295 in \pm .00098 in (0.075 mm \pm 0.025 mm) Exhaust: .00295 in \pm .00098 in (0.075 mm \pm 0.025 mm)
Carburetor Idling	2100 \pm 200 rpm

Torque Values

Charging Coil Bolt	7.5 \pm 1.5 ft. lb (10 \pm 2 N·m)
Crankcase Bolt	21 \pm 1.5 ft. lb (28 \pm 2 N·m)
Cylinder Head Bolt	59 \pm 2 ft. lb (80 \pm 3 N·m)
Flywheel Cover	7.5 \pm 1.5 ft. lb (10 \pm 2 N·m)
Flywheel Nut	85 \pm 4 ft. lb (115 \pm 5 N·m)
Fuel Tank Bolt	18 \pm 1.5 ft. lb (24 \pm 2 N·m)
Ignition Coil Bolt	7.5 \pm 1.5 ft. lb (10 \pm 2 N·m)
Oil Drain Bolt	16 \pm 1.5 ft. lb (22 \pm 2 N·m)
Spark Plug	16 \pm 1.5 ft. lb (22 \pm 2 N·m)
Throttle Assembly Bolt	7.5 \pm 1.5 ft. lb (10 \pm 2 N·m)
Valve Cover Bolt	7.5 \pm 1.5 ft. lb (10 \pm 2 N·m)

Engine Diagrams

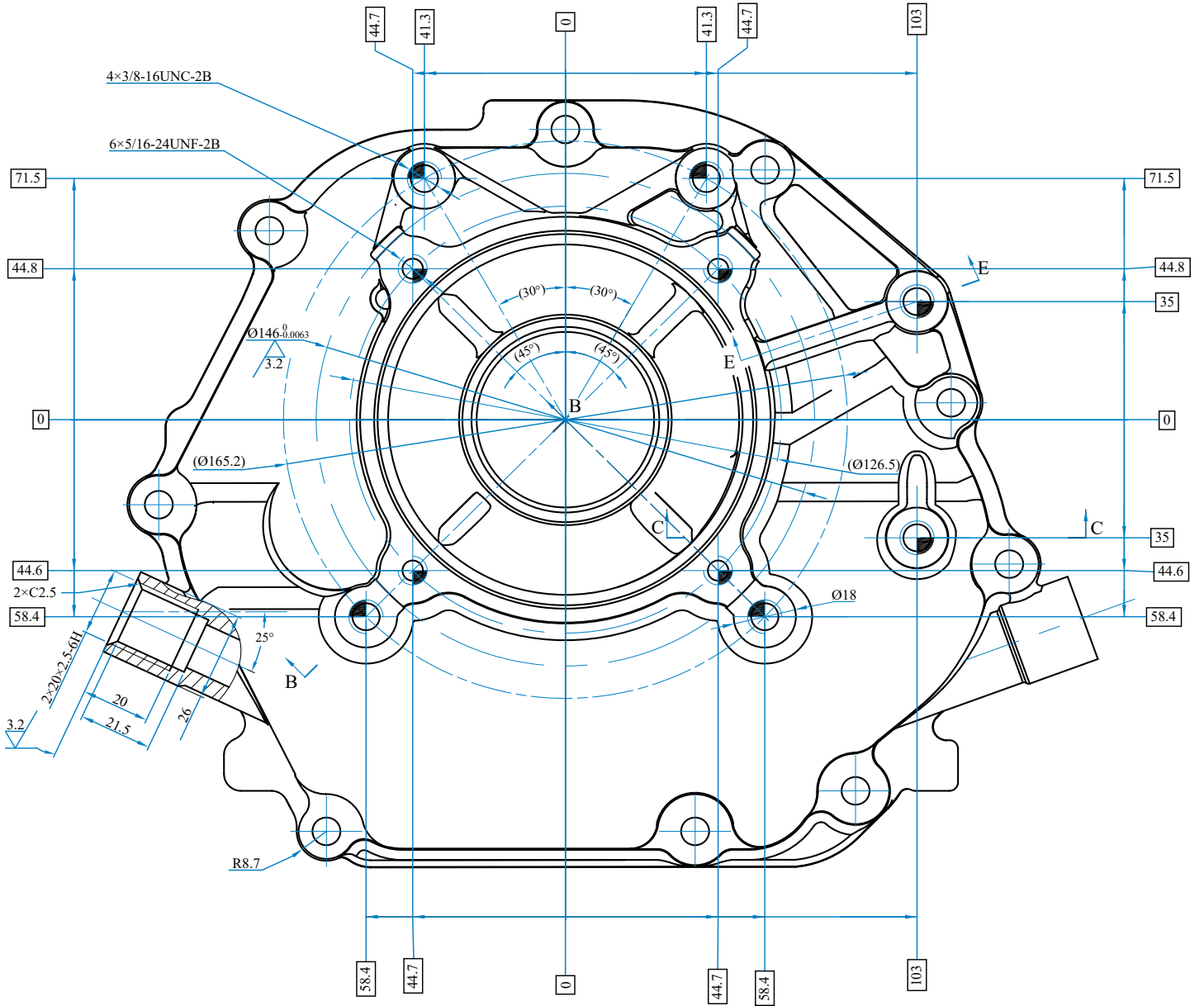

SPECIFICATIONS (CONTINUED)

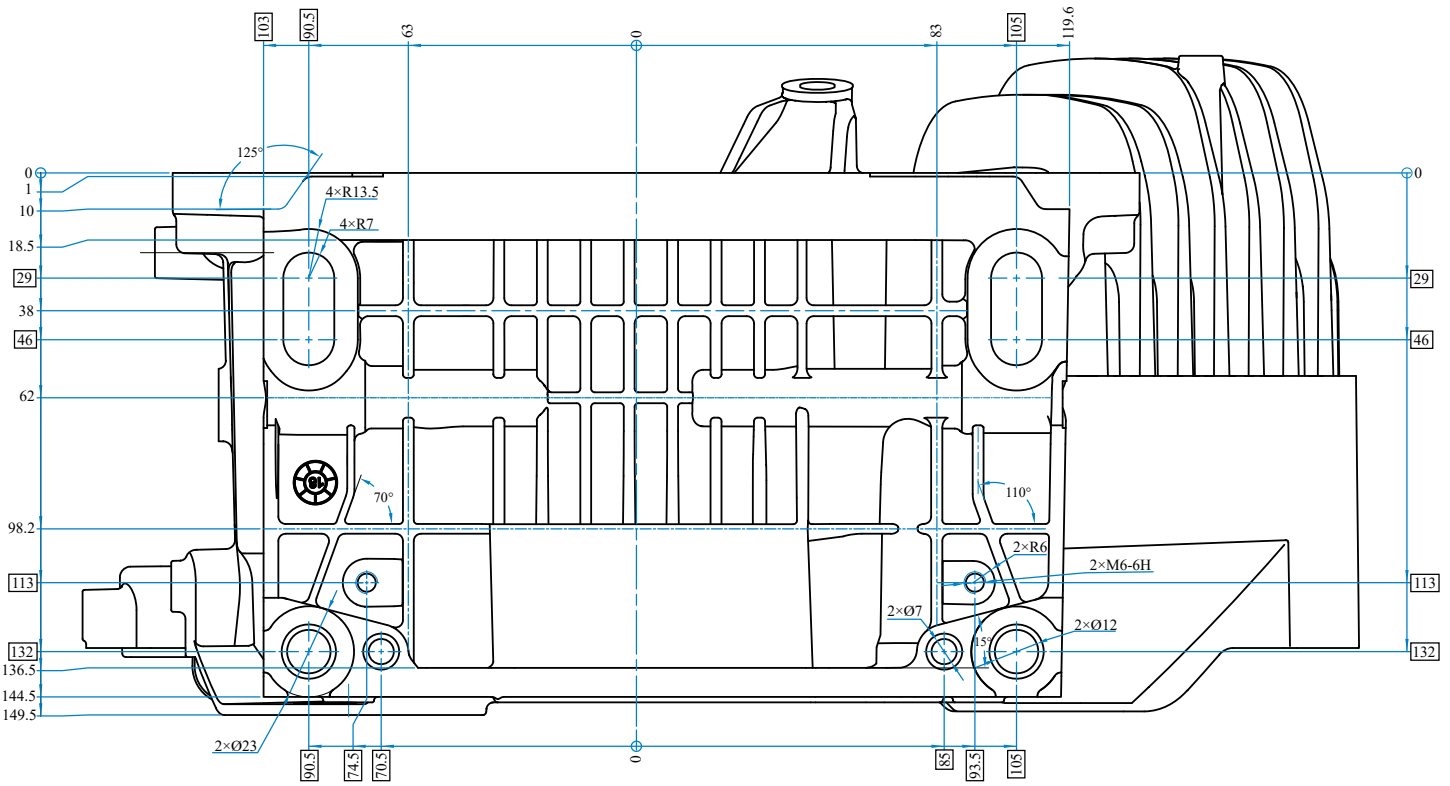
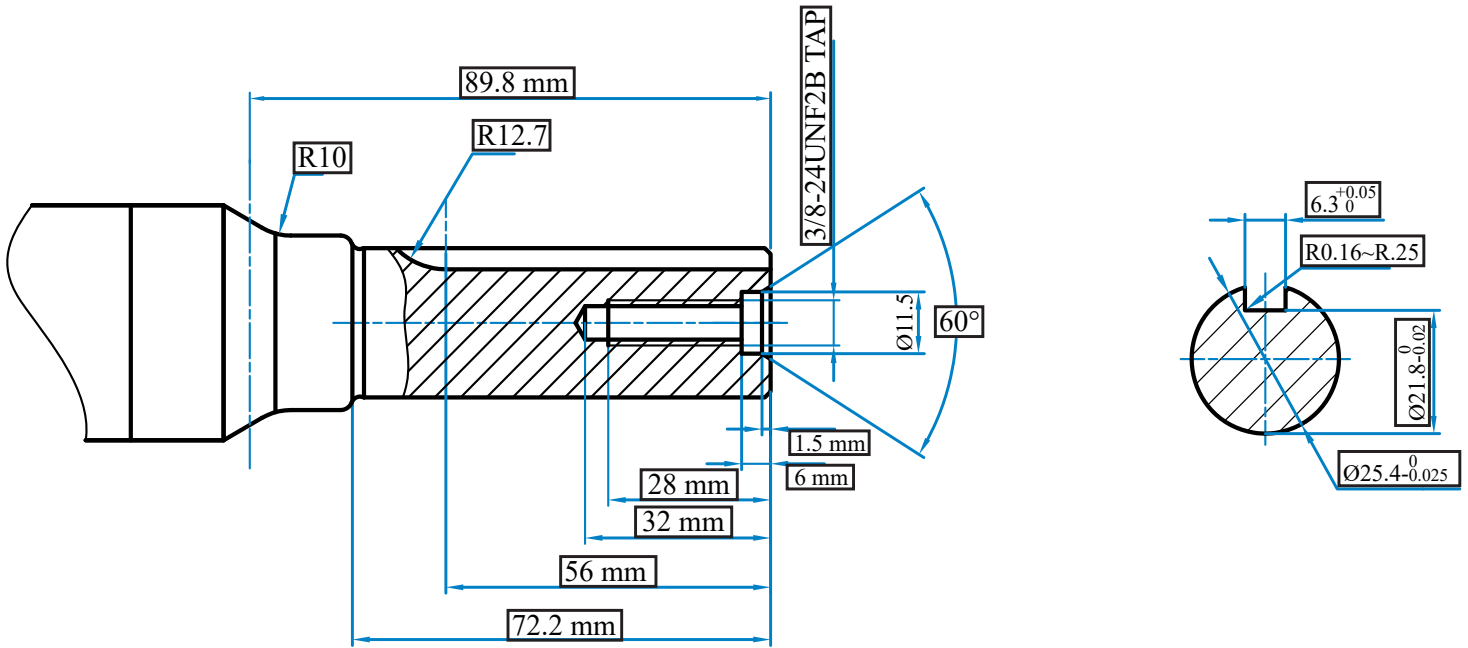

Wiring Diagram

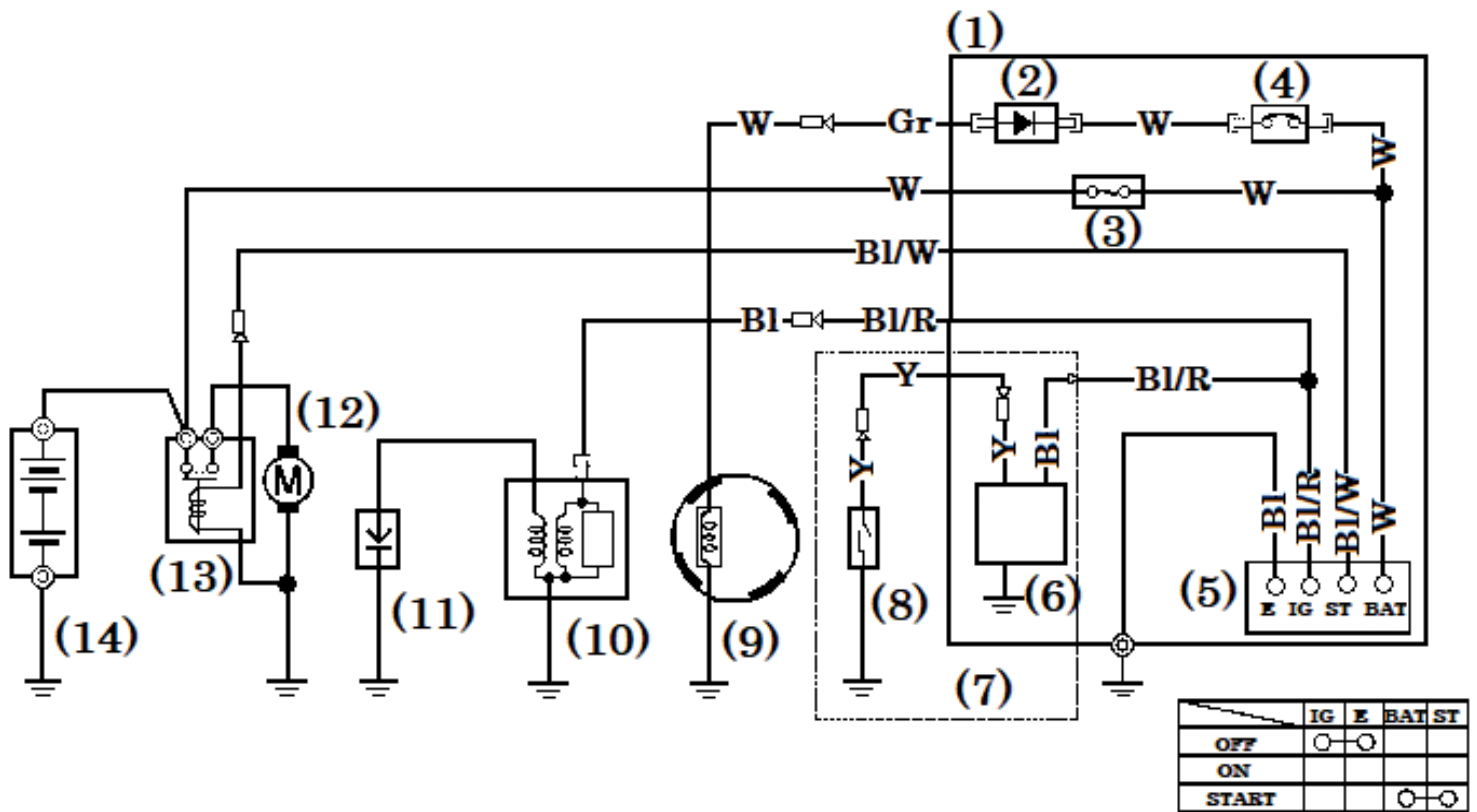

- | | |
|-----------------------------|----------------------|
| 1. Control Box | 8. Oil Level Switch |
| 2. Rectifier | 9. Charging Coil |
| 3. Fuse | 10. Ignition Coil |
| 4. Circuit Breaker | 11. Spark Plug |
| 5. Engine Switch | 12. Starter Motor |
| 6. Oil Alert Unit | 13. Starter Solenoid |
| 7. Type With Oil Alert Unit | 14. Battery (12V) |

BI	Black
Y	Yellow
Gr	Gray
R	Red
W	White
BI/W	Black/White
BI/R	Black/Red

TROUBLESHOOTING

Mode	Description	Solution
Engine will not start	Engine switch is "OFF"	Set engine switch to "ON"
	Fuel valve is "OFF"	Turn fuel valve to "ON"
	Choke is open	Close the choke
	Engine is out of fuel	Add fuel
	Fuel is old or contaminated	Change fuel
	Spark plug is dirty	Clean spark plug
	Spark plug is broken	Replace spark plug
	Engine is not level	Move engine to a level surface
	Oil is low	Add/ change oil
Engine starts, but shuts off after running for short time.	Oil level is low	Add change oil
	Fuel is old or contaminated	Change fuel
	Engine is on incline exceeding 15°	Disconnect low oil sensor
Electric key switch doesn't start or shut off engine.	Key switch separated from frame of engine	Run ground wire from engine block to key switch
	Negative battery or positive battery cable aren't connected properly	See page 18 in the owners manual for proper installation of battery cables
	Battery is dead or defective	Charge or replace battery

Date	Engine Hours	Maintenance Performed



5800 Ontario Mills Parkway
Ontario, CA 91764
United States

844-DUROMAX