



XP18HPX

S E R V I C E M A N U A L



REV: XP18HPX_rev06222023

This manual provides information regarding the operation and maintenance of these products. We have made every effort to ensure the accuracy of the information in this manual. We reserve the right to change this product at any time without prior notice.

5800 Ontario Mills Pkwy
Ontario, CA 91764 USA
www.duromaxpower.com
Call our Customer Care Team Toll Free 8-5 pm PST Mon-Fri
844-DUROMAX



CONTENTS

1.	Engine Components	
	Engine Components	7
2.	Maintenance and Care	
	Maintenance Schedule	8
	Break-In Period	9
	High Altitude Operation	9
	Changing the Carburetor Main Jet.....	10
	Checking the Oil	14
	Changing the Oil.....	15
	Changing the Air Filter.....	16
	Spark Plug Maintenance	18
	Removing the Propane Hose (Optional)	20
	Emptying the Gas Tank	22
	Storing the Engine for Same Day Use	24
	Storing the Engine for Use Within 30 Days.....	25
	Storing the Engine for Longer Than 30 Days.....	26
	Check and Adjust Valve Clearance.....	28
3.	Specifications	
	Specifications.....	32
	Adjustment, Torque Values, and Timing Distribution	33
4.	Engine Diagrams	
	Engine Diagrams	34
	Wiring Diagram	36
5.	Troubleshooting	
	Troubleshooting.....	37

6.

Common Engine Parts

Common Engine Parts..... **38**

7.

Maintenance Log

Maintenance Log..... **43**



POWERING EVERYONE...
ANYWHERE!



POWERING EVERYONE...
ANYWHERE!

ENGINE COMPONENTS

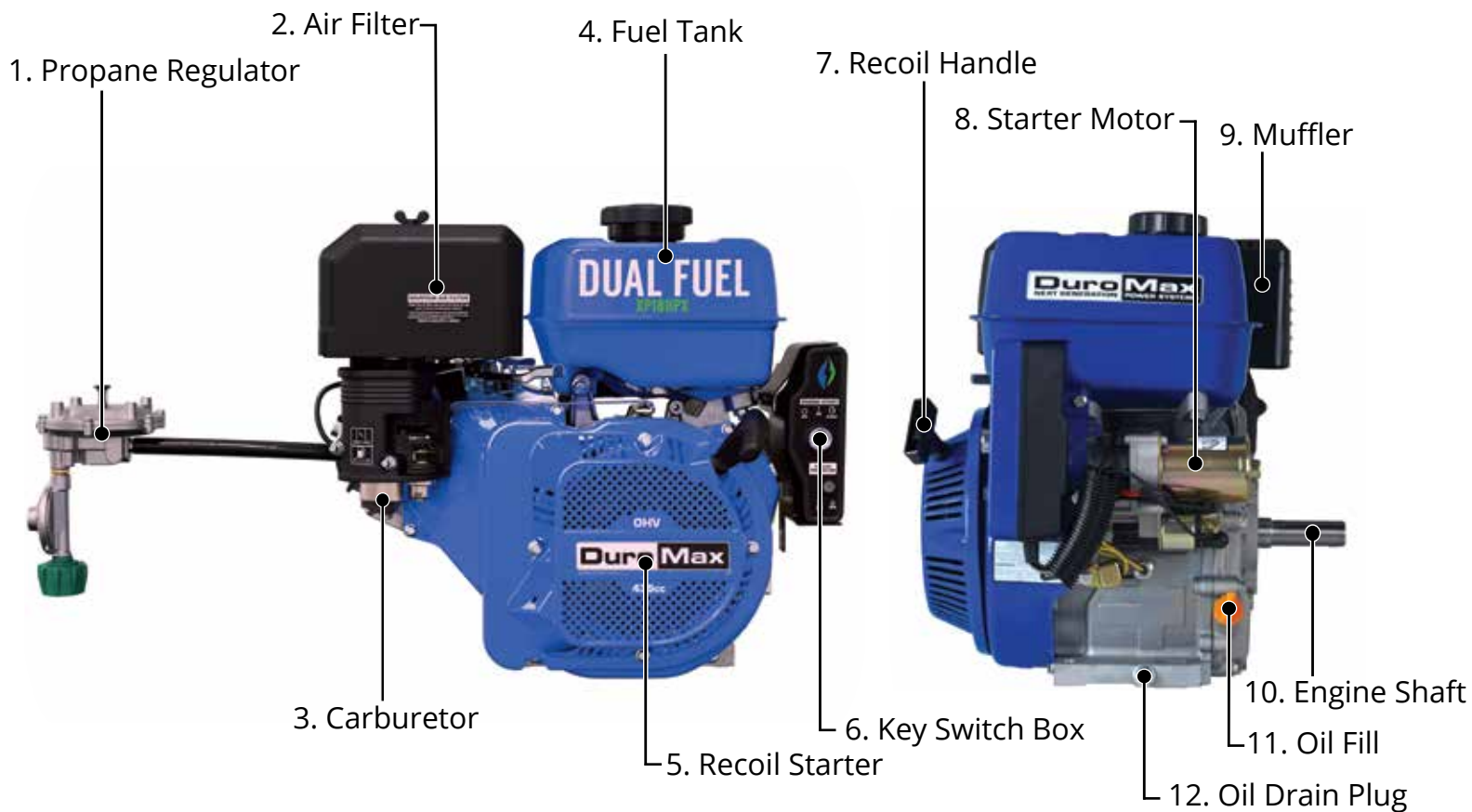

1. **Propane Regulator** - A propane regulator with included hose that easily installs on a propane tank.
2. **Air Filter** - A removable, cleanable, oiled, element that cleans the air going into the engine.
3. **Carburetor** - A component used to control the air fuel mixture of the engine.
4. **Fuel Tank** - All metal 1.4 gallon gasoline fuel tank.
5. **Recoil Starter** - An easy pull recoil start to start the engine without the electric start.
6. **Key Switch Box** - An electric start switch that engages the starter motor with the turn of a key.
7. **Recoil Handle** - An easy grip handle used to pull the recoil starter rope.
8. **Starter Motor** - Electric motor that starts the generator electrically for easy starting.
9. **Muffler** - A noise dampening component that helps lower the engine decibel level.
10. **Engine Shaft** - A 1" diameter, 2-3/4" long all metal shaft with a 1/4" keyway.
11. **Oil Fill** - An easy access location to fill the oil for the engine.
12. **Oil Drain Plug** - An easy to remove oil plug that is used to drain the oil.

MAINTENANCE AND CARE

Proper routine maintenance of your engine is essential for safe, economical, and trouble-free operation. It will also help reduce air pollution.



WARNING: Improper maintenance, or failure to correct a problem before operation, can cause a malfunction in which you can be seriously injured or killed. Always follow the inspection, maintenance recommendations, and schedules in this instruction manual.

- Make sure the engine is off before you begin any maintenance or repairs.
- Let the engine and exhaust system cool before touching.
- To reduce the possibility of fire or explosion, be careful when working around gasoline. Use only a nonflammable solvent, not gasoline, to clean parts. Keep cigarettes, sparks, and flames away from all fuel-related parts.

Maintenance Schedule

Remember that this schedule is based on the assumption that your machine will be used for its designed purpose. Sustained high-load, high-temperature operation, or use in unusually wet or dusty conditions, will require more frequent service.

SERVICE	EVERY USE	1ST MO. OR 8 HRS. (BREAK IN)	EVERY 3 MO. OR 50 HRS. OF HEAVY USE	EVERY 6 MO. OR 100 HRS. OF NORMAL USE	EVERY 12 MO. OR 300 HRS.	EVERY 3 YRS. OR 500 HRS.
ENGINE OIL	CHECK	CHANGE	CHANGE	CHANGE		
AIR CLEANER	CHECK	CHECK	CHANGE	CHANGE		
SPARK PLUG			CLEAN / ADJUST	CLEAN / ADJUST		
SPARK ARRESTOR	CHECK				CLEAN	
IDLE SPEED					CHECK / ADJUST	
VALVE CLEARANCE					CHECK / ADJUST	
FUEL TUBE	CHECK				CHECK / REPLACE	
FUEL TANK / FILTER					CLEAN	
COMBUSTION CHAMBER						CLEAN

Break-In Period

As the best practice for any new combustion motor it's recommended to perform the break in procedure as follows:

- Run the engine for the first 6-8 hours on conventional oil, then change the oil. After the break-in period synthetic oil may be used.
- During the break in period of the first 6-8 hours keep the engine speed under 50% for optimal results.
- Check and clean the air filter if necessary after the break-in period.

High Altitude Operation

At high altitudes, the standard carburetor air/fuel mixture will be too rich. The performance will decrease, and fuel consumption will increase. A very rich mixture will also foul the spark plug and cause hard starting. Operation at an altitude that differs from that at which this engine was certified, for extended periods of time, may increase emissions. High altitude performance can be improved by specific modifications to the carburetor. If you always operate your engine at altitudes above 3,000 feet (900 meters), have a dealer perform this carburetor modification. This engine, when operated at high altitude with the carburetor modifications for high altitude use, will meet each emission standard throughout its useful life. Even with carburetor modification, engine horsepower will decrease by about 3.5% for each 1,000-foot (300-meter) increase in altitude. The effect of altitude on horsepower will be greater than this if no carburetor modification is made.

When the carburetor has been modified for high altitude operation, the air/fuel mixture will be too lean for low altitude use. Operation at altitudes below 3,000 feet (900 meters) with a modified carburetor may cause the engine to overheat and result in serious engine damage.

Note: Jet kits available for purchase upon request, please contact us at 844-DUROMAX to set up your parts order.

Altitude Range	Jet Kit Part Number
3,000 ft. - 6,000 ft.	DJ190FD-14100-3KJS
6,000 ft. - 8,000 ft.	DJ190FD-14100-6KJS

Changing the Carburetor Main Jet



1. Turn fuel valve OFF

Turn the fuel valve OFF.



2. Remove carburetor drain bolt

Remove the outward angled bolt that is located on the bottom of the carburetor.



3. Place funnel below drain port

Place funnel with container to catch the gasoline under the drain port location and put drained gasoline in a gasoline safe container.



4. Remove carburetor bowl bolt

Remove the carburetor bowl bolt located under the solenoid with a 10 mm socket wrench.

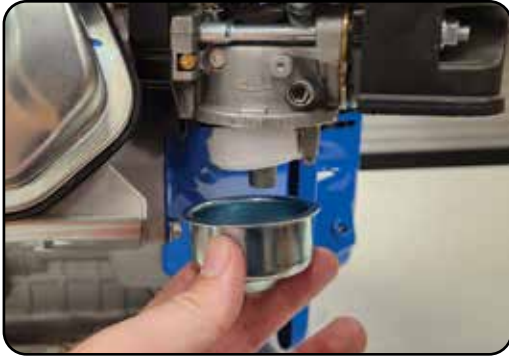

5. Remove carburetor bowl

Remove carburetor bowl from carburetor.

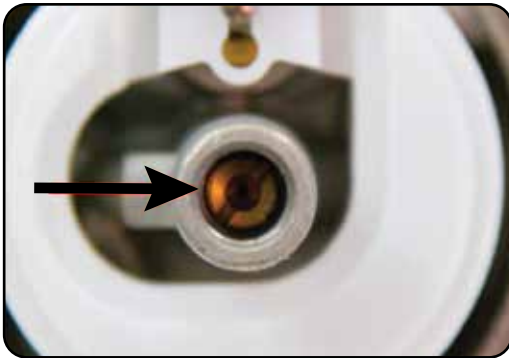

6. Determine main jet location

The carburetor jet is located inside the center metal tube of the carburetor.



7. Remove main jet

Remove the main jet with a flat head screwdriver. If necessary gently tap the carburetor to allow the jet and emulsion tube to fall out.



8. Install new main jet

Place emulsion tube located above the jet back into the carburetor tube in the same position, then install the new main jet.



POWERING EVERYONE...
ANYWHERE!

Changing the Carburetor Main Jet (Continued)



9. Reassemble engine

Once the new jet is installed, reverse the above instructions to reassemble carburetor.

Checking the Oil



Check the oil

The engine is equipped with an automatic shutoff to protect it from damage due to low oil. Nonetheless, you should check the oil level of the engine before each use to ensure that the engine crankcase has a sufficient amount.

To check the oil level:

- a. Make sure the engine is on a level surface.
- b. Unscrew the oil filler/dipstick cap.
- c. With a dry cloth, wipe the oil off of the stick on the inside of the cap.
- d. Insert the dipstick as if you were replacing the cap and then remove it again. There should now be oil on the stick. If there is no oil on the stick, or oil only at the very end of the stick, you should add oil until the engine crankcase is filled (see “Adding Oil” portion of the “Maintenance” section).
- e. The oil will be visible in the oil fill spout when full.
- f. Be sure to replace the cap when finished checking oil.



Model Number	XP18HPX
Engine Oil Capacity	37.2 fl. oz (1.1 L)

Changing the Oil



CAUTION: Worn out or dirty oil does not cool the engine properly and can lead to catastrophic engine damage.

In addition to regular oil changes, it is necessary to drain the oil from the crankcase if it has become contaminated with water or dirt.



1. Remove drain plug

Using a 12 mm hex wrench, unscrew the oil drain plug, which is located on the crankcase underneath the oil filler/dipstick cap.

Allow all the oil to drain from the engine.



2. Drain oil

Drain oil into an approved oil disposal container. Contact your local auto parts store for information on oil disposal.



3. Replace drain plug

Replace the oil drain plug and tighten with a 12 mm hex wrench.

Changing the Air Filter

MAINTAIN AIR FILTER

Clean air filter after every 50 hours of use
(every 10 hours in unusually dusty conditions)

Wash filter element with household detergents.
Wipe out dust from air filter housing before
replacing filter element.

Never clean with a brush

Routine maintenance of the air cleaner helps maintain proper airflow to the carburetor. Check that the air cleaner is free of excessive dirt after every use.



CAUTION: Improper maintenance may cause less air to enter the engine or dirty air to enter the engine causing overheating and engine wear.



1. Remove filter cover wing nut

Remove the wing nut located on the top of the air filter cover.

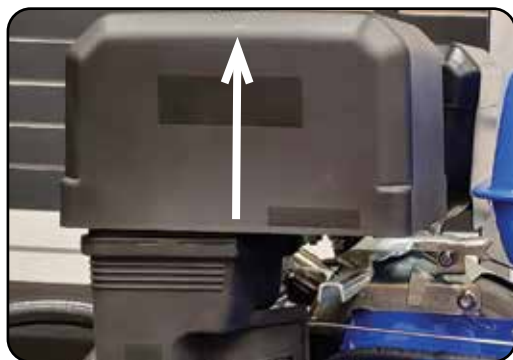

2. Remove filter cover

Remove the plastic air filter cover by lifting the cover upwards to expose the air filter element.



3. Remove old filter element

Remove the wing nut on top of the air filter element and slide filter element off center bolt. This filter is paper and is not reusable. Please call 844-DUROMAX to order a replacement filter for your engine.



4. Replace new filter element

Slide new filter element over center bolt, and replace wing nut. Tighten wing nut hand tight to keep filter in place.

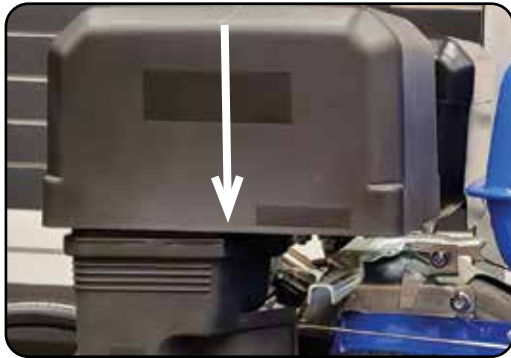

5. Replace filter cover

Replace plastic air filter cover over the air filter base.



6. Secure filter cover

Fasten the air filter cover with the air filter cover wing nut and tighten about hand tight.

MAINTENANCE AND CARE (CONTINUED)

Spark Plug Maintenance



The spark plug is important for proper engine operation. A good spark plug should be intact, free of deposits, and properly gapped.



CAUTION: Improper maintenance may cause reduced fuel economy, misfires, trouble starting, or damage to the spark plug threads.



1. Remove spark plug cap

Pull on the spark plug cap to remove it.



2. Remove spark plug

Unscrew the spark plug from the engine using the spark plug wrench included with this product.



3. Inspect spark plug

Visually inspect the spark plug. If it is cracked or chipped, discard and replace it with a new spark plug. We recommend using an F6RTC spark plug such as NGK BPR6ES.



4. Measure plug gap

Measure the plug gap with a gauge. The gap should be 0.7-0.8 mm (0.028-0.031 in).



5. Clean and re-gap

If you are re-using the spark plug, use a wire brush to clean any dirt from around the spark plug base and then re-gap the spark plug.



6. Install spark plug

Screw the spark plug back into its place on the engine using the spark plug wrench.



7. Replace spark plug cap

Replace the spark plug cap.

Removing the Propane Hose (Optional)

The propane hose is removable if needed. If the propane hose is removed please follow the instructions below for the removal.



CAUTION: If propane hose is removed from the carburetor, then the carburetor connection point should be covered with the provided port plug to avoid debris from entering the engine and causing internal damage.



1. Locate carburetor connection

First follow the propane hose until you run into the connection point on the carburetor.



2. Loosen the hose clamp

Locate the hose clamp at the connection point, and loosen the bolt on the clamp.



3. Remove the propane hose

Once the hose clamp is loose you can remove the propane hose from the carburetor.



4. Install cap on carburetor

Install the provided propane port cap on the carburetor to ensure no dirt gets inside the carburetor.

Emptying the Gas Tank



If you have been using gasoline in your engine, before storing your engine for extended periods of time you should drain your engine fuel tank of gasoline.



CAUTION: Do not store fuel from one season to another. Gasoline sold at the pump today contains additives such as ethanol that even when stored properly may damage the fuel system components.

1. Shut fuel valve OFF

Turn the fuel valve to the "OFF" position.



2. Remove carburetor drain bolt

Remove the outward angled bolt that is located on the bottom of the carburetor.



3. Place funnel below drain port

Place funnel with container to catch the gasoline under the drain port location.





4. Turn fuel valve ON and drain

Turn the fuel valve to “ON” and allow gasoline to drain into the container until the gas tank is empty.



5. Shut fuel valve OFF

Once the gasoline is fully drained, move the fuel valve back to the OFF position.



6. Replace carburetor drain bolt

Reinstall the carburetor drain bolt.



7. Store emptied gasoline

Store the emptied gasoline in a suitable place and add fuel stabilizer to keep fuel fresh and usable.

Storing the Engine for Same Day Use



1. Run the engine

Allow the engine to run for 3-5 minutes.



2. Turn key switch to OFF

Move the key switch to the OFF position to shut the engine off.



3. Store engine

After the engine shuts off and cools, then you can store the engine.



CAUTION: Do not obstruct any ventilation openings and keep the engine in a cool dry area.

Storing the Engine for Use Within 30 Days



1. Run the engine

Allow the engine to run for 3-5 minutes.



2. Shut fuel valve OFF and run dry

Shut the fuel valve off and allow engine to run until it stalls out.



3. Turn the key switch OFF

Move the key switch to the OFF position to shut the engine off.



4. Add fuel stabilizer and store

Add fuel stabilizer to gas remaining in tank, and store the engine.

Storing the Engine for Longer Than 30 Days



1. Run the engine

Allow the engine to run for 3-5 minutes.



2. Shut fuel valve OFF and run dry

Shut the fuel valve off and allow engine to run until it stalls out.



3. Turn the key switch OFF

Move the key switch to the OFF position to shut the engine off.



4. Empty the gas tank

Fully drain your gas tank as shown in "Emptying the Gas Tank" on page 22-23.



5. Remove spark plug

Remove spark plug as shown in “Spark Plug Maintenance” on page 18.



6. Add oil to cylinder

Add 2 tablespoons of 10W-30 motor oil directly into the spark plug hole, and pull the recoil to lubricate cylinder. After lubricating cylinder reinstall the spark plug as shown in “Spark Plug Maintenance” on page 19.



7. Store engine

The engine is ready to be stored in a cool dry area.



CAUTION: Do not obstruct any ventilation openings and keep the engine in a cool dry area.

Check and Adjust Valve Clearance



The engine intake and exhaust valve clearance should be checked and if necessary adjusted every 300 hours of use or 12 month period, whichever comes first.



CAUTION: If the valve clearance isn't maintained, this can cause the engine to run less efficiently and potentially cause engine damage.



1. Remove muffler

Remove both muffler bolts with a 13 mm wrench, then remove the muffler from the engine.



2. Remove spark plug cap

Pull off spark plug cap from spark plug.



3. Remove air filter cover

Remove unscrew top air filter cover nut, and remove air filter cover.



4. Remove spark plug

Remove the spark plug with the provided spark plug wrench.



5. Remove valve cover

Remove all 4 bolts on the valve cover with an 8 mm socket wrench, then remove the valve cover.



6. Set valves to top dead center

Place screwdriver into spark plug hole to help determine the position of the piston, then slowly pull the recoil rope until the piston rises to the top position and both valves are closed (compression step).



7. Check intake valve clearance

The intake valve is on the right side of the cylinder head. Slide a 0.006" (0.152 mm) feeler gauge in-between the valve head and rocker arm. If the feeler gauge is too loose, then tighten the rocker nut until the feeler fits firmly in the gap; but not too tight that you can't remove it. If the feeler doesn't fit in the gap, then loosen the rocker nut until feeler gauge fits firmly inside the gap.



POWERING EVERYONE...
ANYWHERE!

Check and Adjust Valve Clearance (Continued)



8. Check exhaust valve clearance

The exhaust valve is on the left side of the cylinder head. Slide a 0.008" (0.203 mm) feeler gauge in-between the valve head and rocker arm. If the feeler gauge is too loose, then tighten the rocker nut until the feeler fits firmly in the gap; but not too tight that you can't remove it. If the feeler doesn't fit in the gap, then loosen the rocker nut until feeler gauge fits firmly inside the gap.



9. Reinstall parts

Reinstall the valve cover, spark plug, and ignition coil wire. The valve cover should be tightened to 7.5 ± 1.5 ft. lbs (10 ± 2 N·m). The spark plug should be tightened to 18.5 ft/lbs ± 3.5 ft/lbs (25 ± 5 N·m).

SPECIFICATIONS

Displacement	439cc
Fuel Type	≥87 octane, ≤10% ethanol, unleaded gasoline, propane
Dry Weight	77 lbs
Maximum Torque	27 ft. lb @ 2500 rpm
Compression Ratio	8.4:1
Bore X Stroke	92 mm x 66 mm
Engine Oil Capacity	37.2 oz. (1.1 L)
Fuel Tank Capacity	1.4 gal. (5.325 L)
Lowest Idling Speed	1800 rpm ± 300 rpm
Dimensions	LENGTH 20 in.
	WIDTH 18 in.
	HEIGHT 19 in.
Engine Type	4-Stroke OHV Forced-Air
Ignition System	Non-contact transistor
Lubrication Mode	Splash
Starting Type	Electric / Recoil
Shaft Rotation	Counter-clockwise
Shaft Size	1" diameter, 2-3/4" long, 1/4" key-way
Shaft End	3/8" size 24 UNF - drilled and tapped
Center of Shaft to Base	5"
Gasoline Consumption	≤370 g/kWh
Bearing Type	Stainless steel ball bearing
Cylinder Sleeve Type	Cast iron sleeve
Fuel Delivery System	Carburetor

Adjustment, Torque, and Timing Specifications

Adjustment Specification

Spark Plug Clearance	.027-.031 in. (0.7-0.8 mm)
Spark Plug Type	F6RTC (Torch), F6TC (Torch), BPR6ES (NGK), RN9YC (Champion), WR7DC (Bosch), W20EPR-U (Denso)
Valve Clearance (Cold)	Intake: .006 in \pm .001 in. (0.15 mm \pm 0.02 mm) Exhaust: .008 in \pm .001 in. (0.20 mm \pm 0.02 mm)
Carburetor Idling	1800 \pm 300 rpm

Torque Value

Cylinder Head Bolts	29.5 \pm 2 ft. lbs (40 \pm 3 N·m)
Flywheel Bolt	70 \pm 6 ft. lbs (95 \pm 8 N·m)
Crankcase Bolts	17.5 \pm 1.5 ft. lbs (24 \pm 2 N·m)
Connecting Rod Bolts	11 \pm 0.5 ft. lbs (15 \pm 1 N·m)
Valve Cover Bolt	7.5 \pm 1.5 ft. lbs (10 \pm 2 N·m)
Oil Drain Bolt	17.5 \pm 1.5 ft. lbs (24 \pm 2 N·m)
Ignition Coil Bolts	7.5 \pm 1.5 ft. lbs (10 \pm 2 N·m)
Rocker Arm Nuts	7.5 \pm 1.5 ft. lbs (10 \pm 2 N·m)

Timing Distribution

Intake Open (Timing)	BTDC 10°
Intake Closed (Timing)	ABCD 20°
Exhaust Open (Timing)	BBDC 30°
Exhaust Closed (Timing)	ATDC 10°

Engine Diagrams

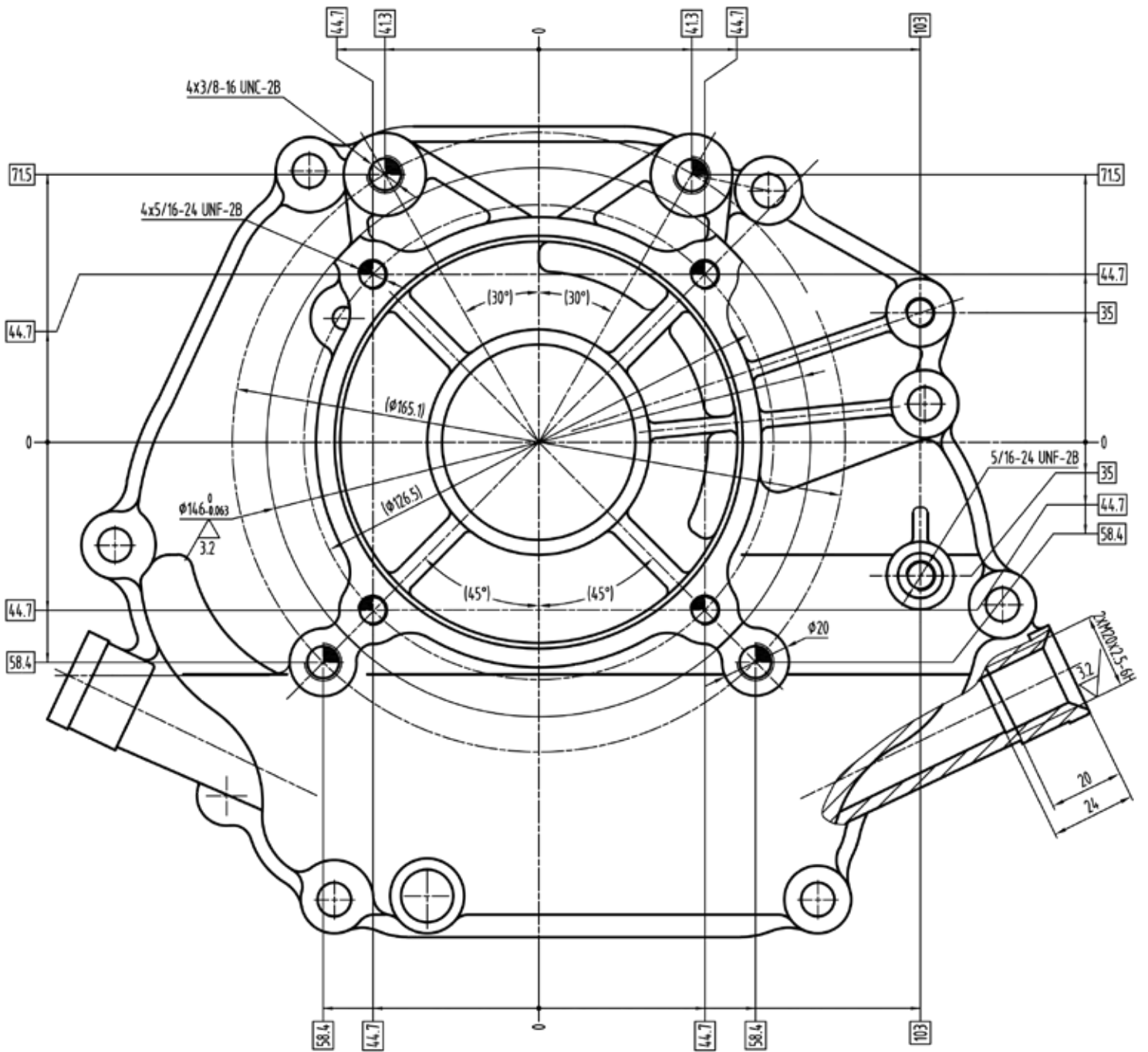

ENGINE DIAGRAMS (CONTINUED)

Wiring Diagram

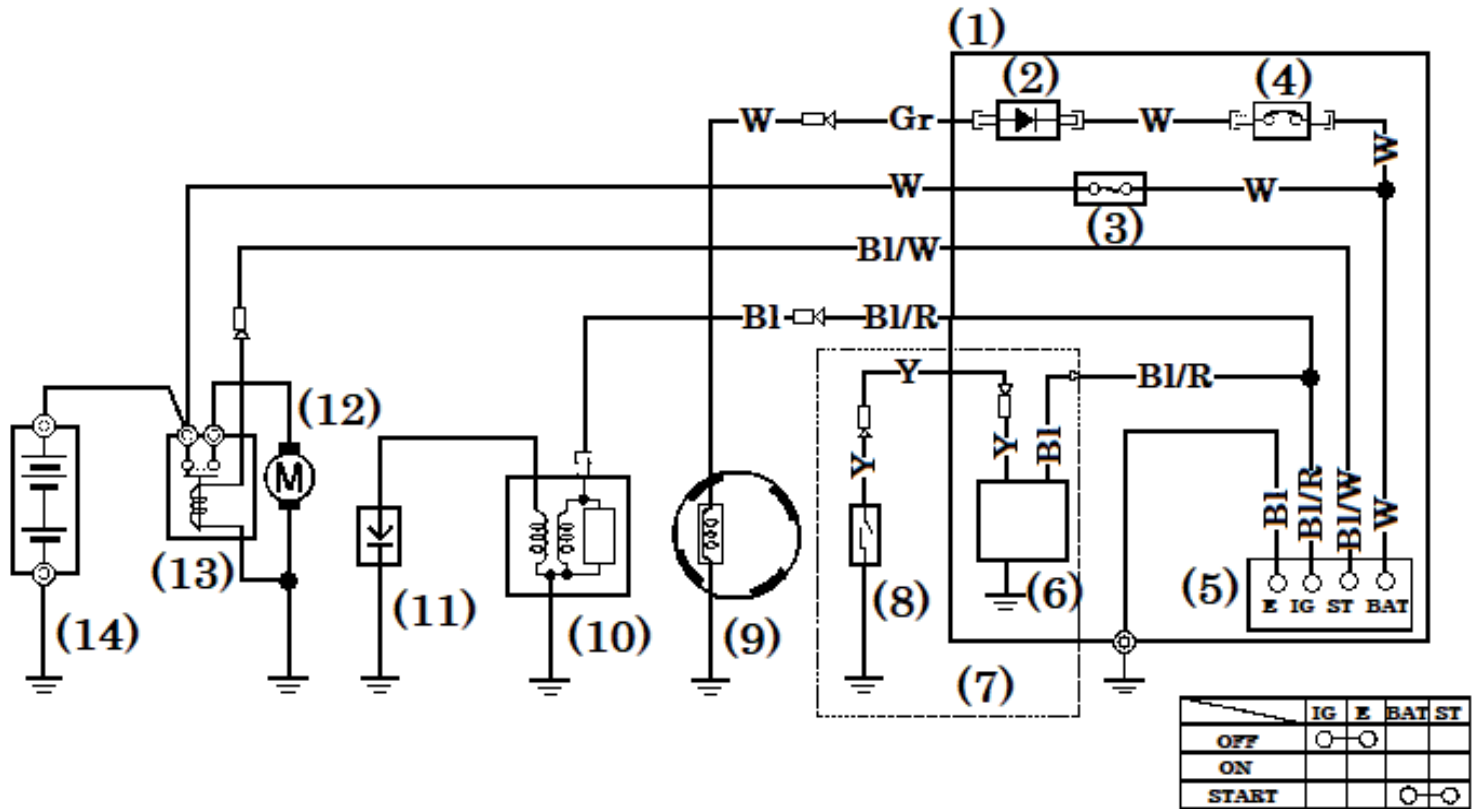

- | | |
|-----------------------------|----------------------|
| 1. Control Box | 8. Oil Level Switch |
| 2. Rectifier | 9. Charging Coil |
| 3. Fuse | 10. Ignition Coil |
| 4. Circuit Breaker | 11. Spark Plug |
| 5. Engine Switch | 12. Starter Motor |
| 6. Oil Alert Unit | 13. Starter Solenoid |
| 7. Type With Oil Alert Unit | 14. Battery (12V) |

BI	Black
Y	Yellow
Gr	Gray
R	Red
W	White
BI/W	Black/White
BI/R	Black/Red

TROUBLESHOOTING

Mode	Description	Solution
Engine will not start	Engine switch is "OFF"	Set engine switch to "ON"
	Fuel valve is "OFF"	Turn fuel valve to "ON"
	Choke is open	Close the choke
	Engine is out of fuel	Add fuel
	Fuel is old or contaminated	Change fuel
	Spark plug is dirty	Clean spark plug
	Spark plug is broken	Replace spark plug
	Engine is not level	Move engine to a level surface
	Oil is low.	Add/change oil
Engine starts, but shuts off after running for short time	Oil level is low	Add/change oil
	Fuel is old or contaminated	Change fuel
	Engine is on incline exceeding 15°	Disconnect low oil sensor
Electric key switch doesn't start or shut off engine	Key switch separated from frame of engine	Run ground wire from engine block to key switch
	Negative battery or positive battery cable aren't connected properly	See installation of battery cables in the owners manual.
	Battery is dead or defective	Charge or replace battery

COMMON ENGINE PARTS

Common Engine Parts

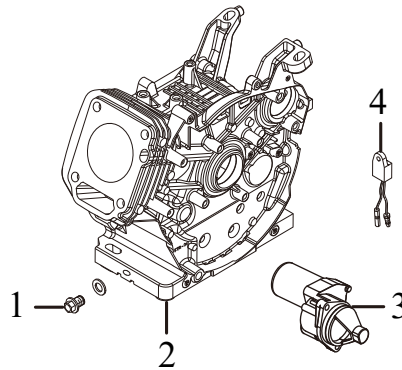

1. Oil Drain Bolt	11007-Z080110-00A0
2. Crankcase Assembly	11310-Z710210-0B00
3. Starting Motor Assembly	09100-Z170210-00A0
4. Oil Protector	37050-Z010210-0000

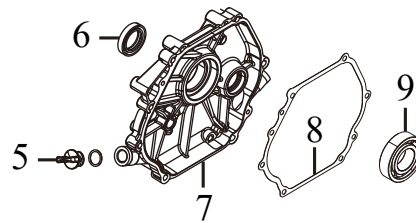

5. Oil Fill Cap/Dipstick	15030-Z080130-Q500
6. Oil Seal	90682-Z310110-0000
7. Crankcase Cover	11411-Z100511-0BA0
8. Crankcase Cover Gasket	11001-Z100120-00A0
9. Crankshaft Bearing	90547-0207-CLTM

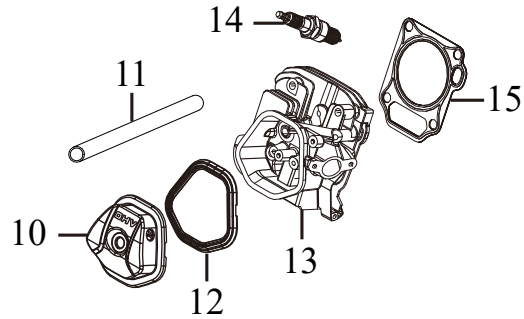

10. Valve Cover	12410-Z310110-0000
11. Breather Hose	17004-Z710210-0000
12. Valve Cover Gasket	12004-Z080110-0001
13. Cylinder Head Assembly	12140-Z710210-0BA9
14. Spark Plug	30010-Z010210-00A0
15. Cylinder Head Gasket	12131-Z710110-00A0

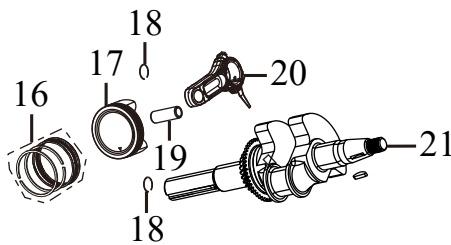

16. Piston Rings	13200-Z710210-00A9
17. Piston	13111-Z710210-00A9
18. Pin Clip	13122-Z100110-00A0
19. Pin	13121-Z710110-00A0
20. Connecting Rod	13010-Z0J0110-00A0
21. Crankshaft Assembly	13300-Z190630-00A0

COMMON ENGINE PARTS (CONTINUED)

Common Engine Parts (CONTINUED)

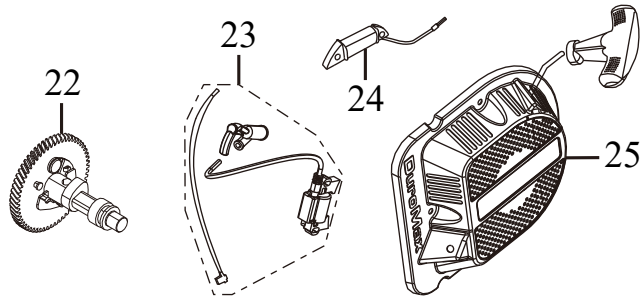

22. Camshaft Assembly	14200-Z190620-00A9
23. Ignition Coil Assembly	30400-Z190210-0000
24. Charge Coil Assembly	30140-Z160130-0000
25. Recoil Assembly	28200-Z710110-BG00

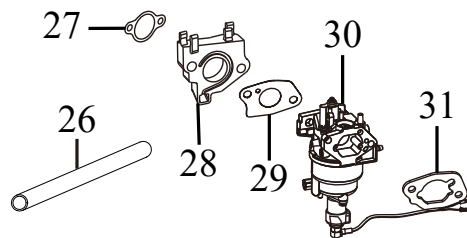

26. Gasoline Fuel Line	90686-Z520110-00M1
27. Spacer/Cylinder Head Gasket	17002-Z100110-0000
28. Spacer Gasket	16003-Z100110-00A0
29. Spacer/Carburetor Gasket	16001-Z100110-00A0
30. Carburetor Assembly	16100-Z0T0510-00M0
31. Air Filter/Carburetor Gasket	17001-Z080210-00A0

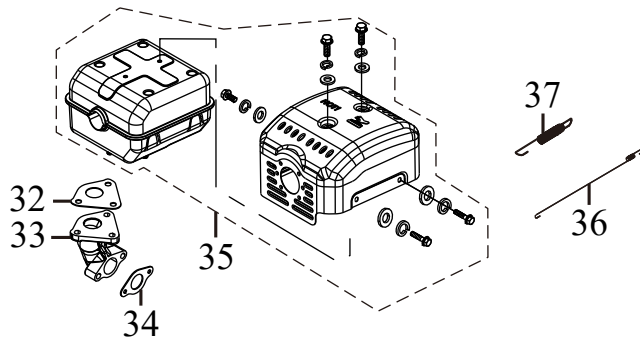

32. Muffler Gasket	18101-Z080110-00A0
33. Manifold Assembly	18150-Z080210-00A0
34. Manifold Gasket	18001-Z190110-00A0
35. Muffler Assembly	18100-Z710510-0000
36. Throttle Return Spring	16012-Z080110-00A0
37. Governor Spring	16063-Z710210-0000

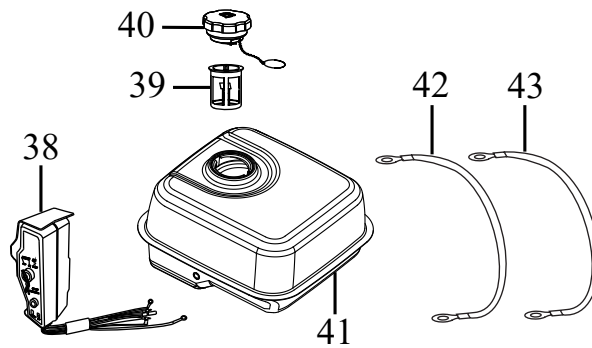

38. Key Switch Assembly	35000-Z161110-H700
39. Fuel Filter	16652-Z010710-00A0
40. Fuel Tank Cap	16730-Z310310-00A0
41. Fuel Tank Assembly	16620-Z310410-BGA0
42. Negative Cable	31112HY130410-0000
43. Positive Cable	31114HY5R0110-0000

COMMON ENGINE PARTS (CONTINUED)

Common Engine Parts (CONTINUED)

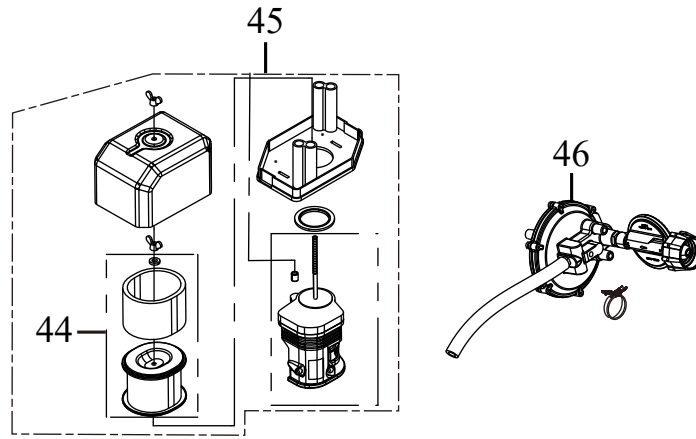

44. Air Filter Element

17150-Z710110-0000

45. Air Filter Assembly

17100-Z710410-0000

46. Propane Regulator Hose

77100HZ0T0110-00A0



POWERING EVERYONE...
ANYWHERE!



5800 Ontario Mills Parkway
Ontario, CA 91764
United States

844-DUROMAX