

Duro Star

DS10000EH

S E R V I C E M A N U A L



This manual provides information regarding the operation and maintenance of these products. We have made every effort to ensure the accuracy of the information in this manual. We reserve the right to change this product at any time without prior notice.

5800 Ontario Mills Pkwy
Ontario, CA 91764 USA
www.duromaxpower.com
Call our Customer Care Team Toll Free 8-5 pm PST Mon-Fri
844-DUROMAX



CONTENTS

1.	Generator Components	
	Generator Components	6
2.	Maintenance and Care	
	Maintenance Schedule	8
	Break-In Period	9
	High Altitude Operation	9
	Changing the Carburetor Main Jet.....	10
	Checking the Oil	14
	Changing the Oil.....	15
	Cleaning the Air Filter	16
	Spark Plug Maintenance	18
	Emptying the Gas Tank	20
	Cleaning the Fuel Filter Cup.....	22
	Transporting the Generator	23
	Storing the Generator for Same Day Use	24
	Storing the Generator for Use Within 30 Days.....	25
	Storing the Generator for Longer Than 30 Days.....	26
	Check and Adjust Valve Clearance.....	28
3.	Specifications	
	Specifications.....	30
	Torque Values	31
4.	Troubleshooting	
	Troubleshooting.....	33
	Changing/Inspecting the Carbon Brushes	34
	Changing/Inspecting the AVR	36

CONTENTS

5.

Generator Diagrams

Common Engine Parts.....	39
Wiring Diagram	46

6.

Maintenance Log

Maintenance Log.....	47
----------------------	----



POWERING EVERYONE...
ANYWHERE!

GENERATOR COMPONENTS

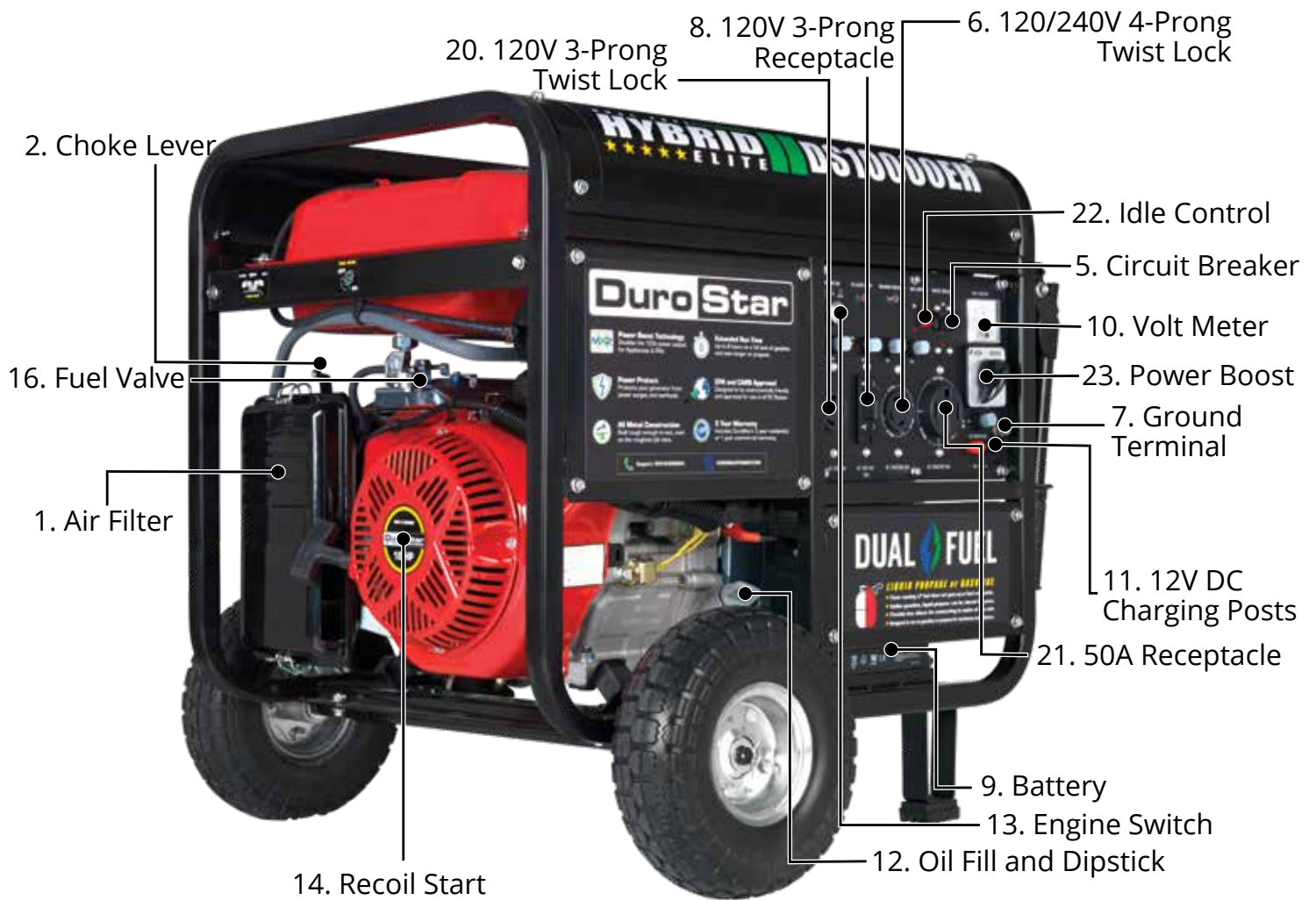

1. **Air Filter** - a removable, cleanable, oiled, element that cleans the air going into the engine.
2. **Choke Lever** - Allows the airflow into the carburetor to be restricted to assist in starting the engine.
3. **Fuel Gauge** - Indicates the amount of fuel in the gasoline tank.
4. **Fuel Cap** - Allows access to fill the gasoline tank.
5. **Circuit Breaker** - Resettable switch that protects the generator from electrical overload.
6. **120/240V 4-Prong Twist Lock** - Use to connect electrical devices that run 120 or 240 Volt, 60Hz, single phase, AC current (NEMA L14-30).
7. **Ground Terminal** - Connect a ground wire here to properly ground the generator.
8. **120V 3-Prong Receptacle** - Use to connect electrical devices that run 120 Volt, 60 Hz, single phase, AC current (NEMA 5-20).
9. **Battery** - 12V DC battery that powers the electric start system.
10. **Volt Meter** - Provides reading of voltage output.
11. **12V DC Charging Posts** - DC output for charging batteries or running small DC powered items.
12. **Oil Fill and Dipstick** - Use to add or check the oil.



- 13. **Engine Switch** – 3 Position Switch to “START”, “RUN”, or turn “OFF” the generator.
- 14. **Recoil Start** – Easy pull recoil start to start the engine without the electric start.
- 15. **Fuel Filter Cup** - Traps dirt and debris in gasoline before it enters the engine.
- 16. **Fuel Valve** - On/Off valve that allows fuel into the engine.
- 17. **Spark plug** – Provides ignition to the engine.
- 18. **Muffler** – Reduces engine emissions and reduces noise.
- 19. **Propane Connector** – Connects the LPG tank to the LPG Regulator. (Intended for use with a LPG source of 3 PSI or more).
- 20. **120V 3-Prong Twist Lock** - Use to connect electrical devices that run 120 Volt, 60 Hz, single phase, AC current (L5-30).
- 21. **50A Receptacle** - Use to connect electrical devices that run 120 or 240 Volt, 60Hz, single phase, AC current (NEMA 14-50).
- 22. **Idle Control** - Runs engine at reduced speed when no load is present to save on fuel and reduce noise levels.
- 23. **Power Boost** - Double the 120V power for appliances & RVs.

MAINTENANCE AND CARE

Proper routine maintenance of your generator is essential for safe, economical, and trouble-free operation. It will also help reduce air pollution.



WARNING: Improper maintenance, or failure to correct a problem before operation, can cause a malfunction in which you can be seriously injured or killed. Always follow the inspection, maintenance recommendations, and schedules in this instruction manual.

- Make sure the engine is off before you begin any maintenance or repairs.
- Let the engine and exhaust system cool before touching.
- To reduce the possibility of fire or explosion, be careful when working around gasoline. Use only a nonflammable solvent, not gasoline, to clean parts. Keep cigarettes, sparks, and flames away from all fuel-related parts.

Maintenance Schedule

Remember that this schedule is based on the assumption that your machine will be used for its designed purpose. Sustained high-load, high-temperature operation, or use in unusually wet or dusty conditions, will require more frequent service.

SERVICE	EVERY USE	1ST MO. OR 8 HRS. (BREAK IN)	EVERY 3 MO. OR 50 HRS. OF HEAVY USE	EVERY 6 MO. OR 100 HRS. OF NORMAL USE	EVERY 12 MO. OR 300 HRS.	EVERY 3 YRS. OR 500 HRS.
ENGINE OIL	CHECK	CHANGE	CHANGE	CHANGE		
AIR CLEANER	CHECK	CHECK	CHANGE	CHANGE		
SEDIMENT CUP			CLEAN	CLEAN		
SPARK PLUG			CLEAN / ADJUST	CLEAN / ADJUST		
SPARK ARRESTOR	CHECK				CLEAN	
IDLE SPEED					CHECK / ADJUST	
VALVE CLEARANCE					CHECK / ADJUST	
FUEL TUBE	CHECK				CHECK / REPLACE	
FUEL TANK / FILTER					CLEAN	
COMBUSTION CHAMBER						CLEAN

Break-In Period

As the best practice for any new combustion motor it's recommended to perform the break in procedure as follows:

- Run the generator for the first 6-8 hours on conventional oil, then change the oil. After the break-in period synthetic oil may be used.
- During the break in period of the first 6-8 hours keep the generator load under 50% for optimal results.
- Check and clean the air filter if necessary after the break-in period.

High Altitude Operation

At high altitudes, the standard carburetor air/fuel mixture will be too rich. The performance will decrease, and fuel consumption will increase. A very rich mixture will also foul the spark plug and cause hard starting. Operation at an altitude that differs from that at which this engine was certified, for extended periods of time, may increase emissions. High altitude performance can be improved by specific modifications to the carburetor. If you always operate your engine at altitudes above 3,000 feet (900 meters), have a dealer perform this carburetor modification. This engine, when operated at high altitude with the carburetor modifications for high altitude use, will meet each emission standard throughout its useful life. Even with carburetor modification, engine horsepower will decrease by about 3.5% for each 1,000-foot (300-meter) increase in altitude. The effect of altitude on horsepower will be greater than this if no carburetor modification is made.

When the carburetor has been modified for high altitude operation, the air/fuel mixture will be too lean for low altitude use. Operation at altitudes below 3,000 feet (900 meters) with a modified carburetor may cause the engine to overheat and result in serious engine damage.

Note: Jet kits available for purchase upon request, please contact us at 844-DUROMAX to set up your parts order.

Altitude Range	Jet Kit Part Number
3,000 ft. - 6,000 ft.	DJ190FD-14100-3KJS
6,000 ft. - 8,000 ft.	DJ190FD-14100-6KJS

MAINTENANCE AND CARE (CONTINUED)

Changing the Carburetor Main Jet



1. Unclip the cover and element

Unclip and remove the air filter cover, then remove the air filter elements.

NOTE: Carburetor should be drained of all gasoline prior to servicing.



2. Unbolt element holder

Remove all 6 bolts of the element holder with an 8mm socket wrench, then remove the element holder.



3. Remove air filter nuts

Remove the 2 front facing nuts connecting the air filter to the carburetor.



4. Remove air filter bracket nut

Remove the nut attaching the bottom air filter bracket located behind the air filter housing.



5. Remove air filter hose

Remove air filter hose clip with pliers and remove hose from behind air filter.



6. Remove carburetor solenoid

Remove both Phillips screws attaching carburetor solenoid with a standard Phillips screwdriver.



7. Remove carburetor bowl bolt

Remove the carburetor bowl bolt located under the solenoid with a 14 mm socket wrench.



8. Remove carburetor bowl

Remove the carburetor bowl from carburetor.



POWERING EVERYONE...
ANYWHERE!

MAINTENANCE AND CARE (CONTINUED)

Changing the Carburetor Main Jet (Continued)

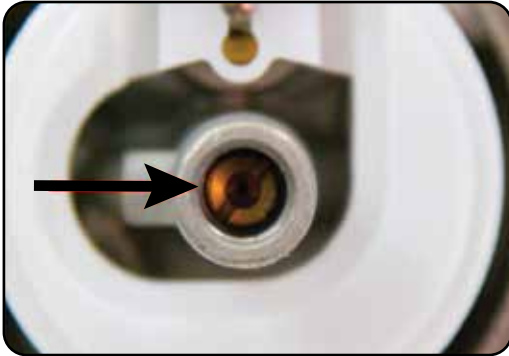

9. Determine main jet location

The carburetor jet is located inside the center metal tube of the carburetor.



10. Remove main jet

Remove the main jet with a flat head screwdriver. If necessary gently tap the carburetor to allow the jet and emulsion tube to fall out.



11. Install new main jet

Place emulsion tube located above the jet back into the carburetor tube in the same position, then install the new main jet.



12. Reassemble generator

Once the new jet is installed, reverse the above instructions to reassemble carburetor and reinstall air filter assembly.

MAINTENANCE AND CARE (CONTINUED)

Checking the Oil



Check the oil

The generator is equipped with an automatic shutoff to protect it from damage due to low oil. Nonetheless, you should check the oil level of the engine before each use to ensure that the engine crankcase has a sufficient amount.

To check the oil level:

- a. Make sure the generator is on a level surface.
- b. Unscrew the oil filler/dipstick cap.
- c. With a dry cloth, wipe the oil off of the stick on the inside of the cap.
- d. Insert the dipstick as if you were replacing the cap and then remove it again. There should now be oil on the stick. If there is no oil on the stick, or oil only at the very end of the stick, you should add oil until the engine crankcase is filled (see “Adding Oil” portion of the “Maintenance” section).
- e. The oil will be visible in the oil fill spout when full.
- f. Be sure to replace the cap when finished checking oil.



Model Number	DS10000EH
Engine Oil Capacity	37.2 fl. oz (1.1 L)

Changing the Oil



CAUTION: Worn out or dirty oil does not cool the generator properly and can lead to catastrophic engine damage.

In addition to regular oil changes, it is necessary to drain the oil from the crankcase if it has become contaminated with water or dirt.



1. Remove drain plug

Using a 12 mm hex wrench, unscrew the oil drain plug, which is located on the crankcase underneath the oil filler/dipstick cap.

Allow all the oil to drain from the generator.



2. Drain oil

Drain oil into an approved oil disposal container. Contact your local auto parts store for information on oil disposal.



3. Replace drain plug

Replace the oil drain plug and tighten with a 12 mm hex wrench.

MAINTENANCE AND CARE (CONTINUED)

Cleaning the Air Filter

MAINTAIN AIR FILTER

Clean air filter after every 50 hours of use
(every 10 hours in unusually dusty conditions)

Wash filter element with household detergents.
Wipe out dust from air filter housing before
replacing filter element.

Never clean with a brush

Routine maintenance of the air cleaner helps maintain proper airflow to the carburetor. Check that the air cleaner is free of excessive dirt after every use.



CAUTION: Improper maintenance may cause less air to enter the engine or dirty air to enter the engine causing overheating and engine wear.



1. Remove the filter cover

Release the clips on the top and bottom of the cover and remove the filter cover.



2. Remove filter

Remove the sponge-like elements from the casing.



3. Clean out filter casing

Wipe the dirt from inside the empty air cleaner casing.



4. Wash cleaner element

Wash the sponge-like elements in household dish detergent and warm water.



5. Dry cleaner element

Pat dry on a dry cloth and allow the elements to dry completely.



6. Add engine oil to elements

Soak the dry elements in a small amount of engine oil. Ring out any excess oil.



7. Replace elements in casing

Replace the sponge-like elements in the air cleaner casing and replace the cover.

MAINTENANCE AND CARE (CONTINUED)

Spark Plug Maintenance



The spark plug is important for proper engine operation. A good spark plug should be intact, free of deposits, and properly gapped.



CAUTION: Improper maintenance may cause reduced fuel economy, misfires, trouble starting, or damage to the spark plug threads.



1. Remove spark plug cap

Pull on the spark plug cap to remove it.



2. Remove spark plug

Unscrew the spark plug from the generator using the spark plug wrench included with this product.



3. Inspect spark plug

Visually inspect the spark plug. If it is cracked or chipped, discard and replace it with a new spark plug. We recommend using an F6RTC spark plug such as NGK BPR6ES.



4. Measure plug gap

Measure the plug gap with a gauge. The gap should be 0.7-0.8 mm (0.028-0.031 in).



5. Clean and re-gap

If you are re-using the spark plug, use a wire brush to clean any dirt from around the spark plug base and then re-gap the spark plug.



6. Install spark plug

Screw the spark plug back into its place on the generator using the spark plug wrench.



7. Replace spark plug cap

Replace the spark plug cap.

MAINTENANCE AND CARE (CONTINUED)

Emptying the Gas Tank



If you have been using gasoline in your generator, before storing your generator for extended periods of time you should drain your generator fuel tank of gasoline.



CAUTION: Do not store fuel from one season to another. Gasoline sold at the pump today contains additives such as ethanol that even when stored properly may damage the fuel system components.

1. Shut fuel valve OFF

Turn the fuel valve to the “OFF” position.



2. Remove fuel filter cup

Remove the fuel filter cup (see “Removing the Fuel Filter Cup” later in this section).



3. Empty fuel filter cup

Empty the fuel filter cup of any fuel.





4. Drain gas from the generator

With a funnel underneath the fuel valve to catch the gas, turn the fuel valve to the "ON" position. Drain all the gas from the generator.



5. Shut fuel valve OFF

Turn the fuel valve to the "OFF" position.



6. Replace fuel filter cup

Reinstall the fuel filter cup.



7. Store emptied gas

Store the emptied gasoline in a suitable place and add fuel stabilizer to keep fuel fresh and usable.

MAINTENANCE AND CARE (CONTINUED)

Cleaning the Fuel Filter Cup



1. Shut fuel valve off

Turn the fuel valve to the "OFF" position.



2. Remove fuel filter cup

Unscrew the fuel filter cup from the fuel valve using a wrench.



3. Clean filter cup

Clean the cup of all sediment using a rag or brush.



4. Replace fuel filter cup

Reinstall the fuel filter cup.

Transporting the Generator



1. Empty the gas tank

Fully drain your gas tank as shown in “Emptying the Gas Tank” on page 20-21.



2. Disconnect the spark plug

Pull on spark plug cap to disconnect spark plug from ignition wire.



CAUTION: Do not obstruct any ventilation openings and keep the generator in a cool dry area.



CAUTION: Never place any type of storage cover on the generator while it is still hot.

MAINTENANCE AND CARE (CONTINUED)

Storing the Generator for Same Day Use



1. Turn the main breaker OFF

Move the main breaker to the "OFF" position.



2. Run the generator

Allow the generator to run for 3-5 minutes.



3. Turn the key switch OFF

Turn the key switch counter-clockwise to the "OFF" position to shut the generator off.



4. Turn fuel valve OFF/ Store

Turn the fuel valve clockwise to the horizontal position to shut off the flow of gasoline to the carburetor, then store the generator.



CAUTION: Do not obstruct any ventilation openings and keep the generator in a cool dry area.

Storing the Generator for Use Within 30 Days



1. Turn breaker OFF and run

Follow steps 1 and 2 as shown on "Storing the Generator For Same Day Use" on page 24.



2. Shut fuel valve OFF and run dry

Shut the fuel valve "OFF" and allow generator to run until it stalls out.



3. Turn the key switch OFF

Turn the key switch counter-clockwise to the "OFF" position to shut the generator off.



4. Add fuel stabilizer and store

Add fuel stabilizer to gas remaining in tank, and store generator.

MAINTENANCE AND CARE (CONTINUED)

Storing the Generator for Longer Than 30 Days



1. Turn breaker OFF and run

Follow steps 1 and 2 as shown on “Storing the Generator For Same Day Use” on page 24.



2. Shut fuel valve OFF and run dry

Shut the fuel valve “OFF” and allow generator to run until it stalls out.



3. Turn the key switch OFF

Turn the key switch counter-clockwise to the “OFF” position to shut the generator off.



4. Empty the gas tank

Fully drain your gas tank as shown in “Emptying the Gas Tank” on page 20-21.



5. Drain the carburetor

Remove drain bolt from carburetor and drain small amount of fuel in carburetor bowl.



6. Remove spark plug

Remove spark plug as shown in "Spark Plug Maintenance" on page 18.



7. Add oil to cylinder

Add 2 tablespoons of 10W-30 motor oil directly into the spark plug hole, and pull the recoil to lubricate cylinder. After lubricating cylinder reinstall the spark plug.



8. Remove battery and charge

Remove the generator battery and place it on a 12V battery tender indoors.

MAINTENANCE AND CARE (CONTINUED)

Check and Adjust Valve Clearance



The engine intake and exhaust valve clearance should be checked and if necessary adjusted every 300 hours of use or 12 month period, whichever comes first.



CAUTION: If the valve clearance isn't maintained, this can cause the engine to run less efficiently and potentially cause engine damage.



1. Remove spark plug cap

Pull on spark plug cap to disconnect spark plug from ignition wire.



2. Remove valve cover

Remove center valve cover bolt with a 10 mm socket wrench and remove the breather hose; then remove the valve cover.



3. Remove spark plug

Remove the spark plug with the provided spark plug wrench.



4. Set valves to top dead center

Place screwdriver into spark plug hole to help determine the position of the piston, then slowly pull the recoil rope until the piston rises to the top position and both valves are closed (compression step).



5. Check intake valve clearance

The intake valve is on the right side of the cylinder head. Slide a 0.006" (0.152 mm) feeler gauge in-between the valve head and rocker arm. If the feeler gauge is too loose, then tighten the rocker nut until the feeler fits firmly in the gap; but not too tight that you can't remove it. If the feeler doesn't fit in the gap, then loosen the rocker nut until feeler gauge fits firmly inside the gap.



6. Check exhaust valve clearance

The exhaust valve is on the left side of the cylinder head. Slide a 0.008" (0.203 mm) feeler gauge in-between the valve head and rocker arm. If the feeler gauge is too loose, then tighten the rocker nut until the feeler fits firmly in the gap; but not too tight that you can't remove it. If the feeler doesn't fit in the gap, then loosen the rocker nut until feeler gauge fits firmly inside the gap.



7. Reinstall parts

Reinstall the valve cover, spark plug, and ignition coil wire. The valve cover should be tightened to 20.7 ft/lbs \pm 1.5 ft/lbs (28 \pm 2 N·m). The spark plug should be tightened to 18.5 ft/lbs \pm 3.5 ft/lbs (25 \pm 5 N·m).

SPECIFICATIONS

Model Number	DS10000EH
AC Rated Wattage (Gasoline)	8,000 W
AC Rated Wattage (Propane)	7,600 W
AC Surge Wattage (Gasoline)	10,000 W
AC Surge Wattage (Propane)	9,500 W
AC Rated Voltage	120/240V
Dimensions	29"L x 30"W x 26"H
Weight	220 lbs
Recommended Oil	10W-30
Engine Displacement	439 cc
Gasoline Capacity	8.3 gal
Oil Capacity	37.2 fl. oz. (1.1 L)
Bore	92 mm
Stroke	66 mm
Engine Speed	3600 rpm
Oil Cooling Type	Splash
Bearing Type	Stainless steel ball bearing
Cylinder Sleeve	Cast iron sleeve
Fuel Delivery System	Carburetor
Valve Type	OHV
Engine Type	4-Stroke
Engine Cooling Type	Forced air
Run Time @ 50% (Gasoline)	10 hr.
Run Time @ 50% (Propane)	9 hr. (40 lb.)
Starting Type	Electric/ Recoil
Noise Level	<72 dB
Neutral System	Floating
AC Rated Frequency	60 Hz
AC Phase	Single
Winding Material	100% copper windings
Suggested Propane Tank Size	40 lbs. minimum
Emissions Compliance	EPA/CARB

Torque Values

Part Description	Torque Value
Oil Drain Bolt	18.5 ± 1.5 ft. lbs. (24 ± 2 N·m)
Crankcase Cover Bolt	20.5 ± 1.5 ft. lbs. (28 ± 2 N·m)
Flywheel Nut	70 ± 3 ft. lbs. (95 ± 4 N·m)
Ignition Coil Bolt	7.5 ± 1.5 ft. lbs. (10 ± 2 N·m)
Cylinder Head Bolt	35.5 ± 1.5 ft. lbs. (48 ± 2 N·m)
Rocker Arm Nut	7.5 ± 1.5 ft. lbs. (10 ± 2 N·m)
Valve Cover Bolt	5 ± 0.5 ft. lbs. (7 ± 1 N·m)
Spark Plug	16 ± 1.5 ft. lbs. (22 ± 2 N·m)
Muffler Nut	18.5 ± 3.5 ft. lbs. (25 ± 5 N·m)
Exhaust Pipe Nut	20.5 ± 1.5 ft. lbs. (28 ± 2 N·m)
Fuel Valve Nut	7.5 ± 1.5 ft. lbs. (10 ± 2 N·m)
Carburetor Drain Bolt	6 ± 1.5 ft. lbs. (8 ± 2 N·m)
Propane Regulator Bolt	6.5 ± 0.5 ft. lbs. (9 ± 1 N·m)
Handle Tube Assembly	15 ± 0.5 ft. lbs. (20 ± 1 N·m)
Wheel Axle Nut	23 ± 1.5 ft. lbs. (31 ± 2 N·m)
Fuel Tank Bolt	6.5 ± 0.5 ft. lbs. (9 ± 1 N·m)
Air Cleaner Bracket Bolt	6.5 ± 0.5 ft. lbs. (9 ± 1 N·m)
Rotor Bolt	20.5 ± 2 ft. lbs. (27.5 ± 2.5 N·m)
Stator Bolt	6.5 ± 0.5 ft. lbs. (9 ± 1 N·m)



POWERING EVERYONE...
ANYWHERE!

■ TROUBLESHOOTING

Problem	Description	Solution
The engine will not start	Engine switch is "OFF"	Set engine switch to "ON"
	Fuel valve is "CLOSED"	Turn the fuel valve to "OPEN"
	Choke is open	Close the choke
	The engine is out of fuel	Add fuel
	Fuel is old or contaminated	Change fuel
	Spark plug is dirty	Clean spark plug
	Spark plug is broken	Replace spark plug
	The generator is not level	Move the generator to a level surface
	Oil is low	Add/change the oil
Engine runs, but there is no electrical output	The circuit breaker is "OFF"	Turn "ON" circuit breaker
	Wiring connection is bad	Replace extension cord(s)
	Device connected to generator is malfunctioning	Disconnect malfunctioning device
The generator runs but does not support all electrical devices connected	Generator is overloaded	Disconnect 1 or more items to reduce the load
	Device connected to the generator is bad	Disconnect malfunctioning device
	The air filter is dirty	Clean/replace the air filter

■ TROUBLESHOOTING (CONTINUED)

Changing/Inspecting the Carbon Brushes



The carbon brushes in conjunction with the AVR regulates power from the generator. The carbon brushes are wearable parts and should be inspected every 250 running hours.



1. Remove generator cover

Remove the 2 bolts of the generator cover then pull the cover off the generator.



2. Remove bolt from brush

Remove the bolt holding the carbon brush.



3. Disconnect AVR wires

Remove the two wires from the AVR on the carbon brush.



4. Install new brush

Install new carbon brush with bolt.



5. Connect AVR wires

Insert and connect the 2 wires from the AVR, be sure to connect + and - correctly.



6. Replace generator cover

Replace the back cover of the generator and secure it with the 2 bolts.

■ TROUBLESHOOTING (CONTINUED)

Changing/Inspecting the AVR



The carbon brushes in conjunction with the AVR regulates power from the generator. If the generator is overheated or overloaded, the AVR may be damaged and require replacement.



1. Remove generator cover

Remove the 2 bolts of the generator cover then pull the cover off the generator.



2. Remove AVR bolts

Remove the 2 bolts holding the AVR.



3. Disconnect AVR wire clip

Disconnect the wire clip.



4. Disconnect wires from brush

Remove the 2 wires from the AVR on the carbon brush.



5. Install new AVR

Install the new AVR with the 2 bolts.



6. Reconnect wires to brush

Insert and connect the 2 wires from the AVR, be sure to connect + and - correctly.



7. Reconnect the AVR wire clip

Reconnect the wire clip.

■ TROUBLESHOOTING (CONTINUED)

Changing/Inspecting the AVR (Continued)



8. Replace generator cover

Replace the back cover of the generator and secure it with the 2 bolts.

Common Engine Parts

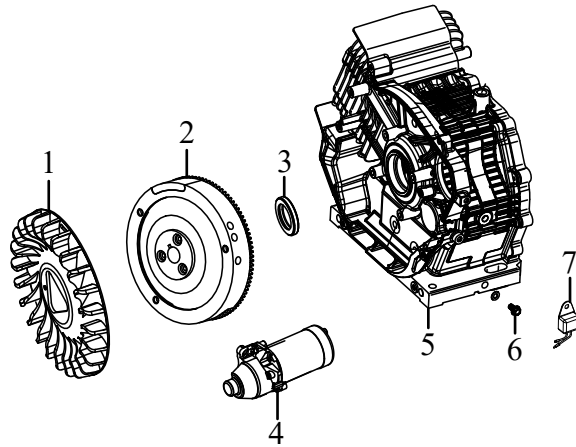

1. Flywheel Fan	19352-Z100210-00A0
2. Flywheel Assembly	13510-Z710110-0000
3. Oil Seal	90682-Z310110-0000
4. Starter Motor Assembly	09100-Z170210-0001
5. Crankcase Assembly	11310-Z710310-0BA0
6. Oil Drain Plug	11007-Z080110-0000
7. Oil Sensor Amplifier	37050-Z010310-0000

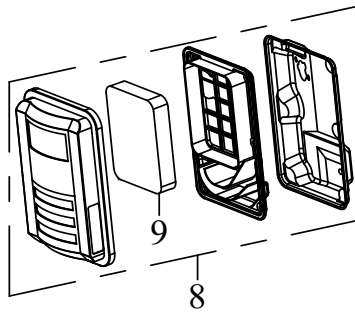

8. Air Filter Assembly	17100-Z310610-0002
9. Air Filter Element	17151-Z310210-0000

COMMON ENGINE PARTS (CONTINUED)

Common Engine Parts (Continued)

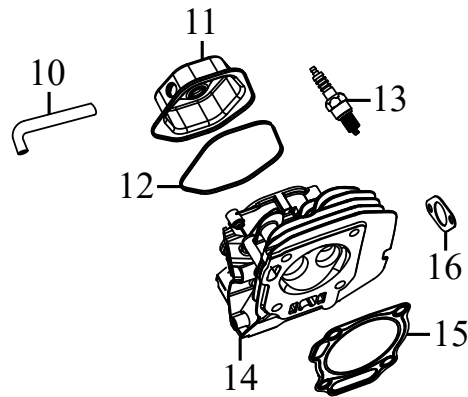

10. Breather Tube	17004-Z080320-0000
11. Valve Cover	12410-Z310110-0000
12. Valve Cover Gasket	12004-Z080110-0000
13. Spark Plug	30010-Z010210-0000
14. Cylinder Head Assembly	12140-Z710510-0BA0
15. Cylinder Head Gasket	12131-Z710110-0000
16. Muffler/Cylinder Head Gasket	18001-Z190110-00A0

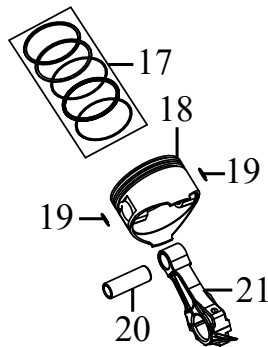

17. Piston Rings	13200-Z710210-0099
18. Piston	13111-Z710210-0099
19. Pin Clip	13122-Z100110-0000
20. Pin	13121-Z710110-0000
21. Connecting Rod	13010-Z190120-00A0

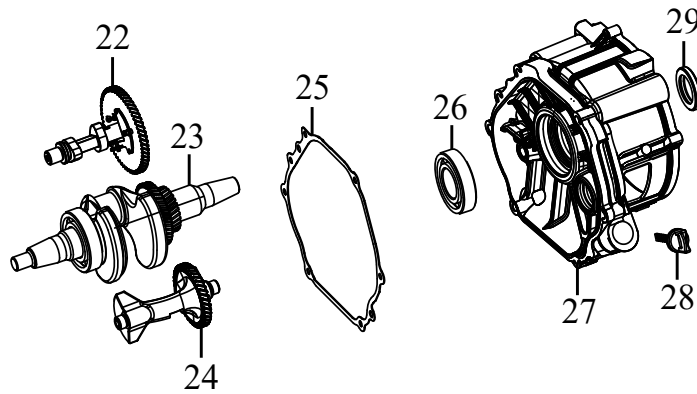

22. Camshaft Assembly	14200-Z1P0110-0000
23. Crankshaft Assembly	13300-Z191310-RBTM
24. Balancing Shaft Assembly	13400-Z190320-0000
25. Crankcase Cover Gasket	11001-Z100120-0000
26. Bearing	90547-0207-00TM
27. Crankcase Cover	11411-Z100610-0B00
28. Oil Cap/Dipstick	15010-Z080330-Q500
29. Oil Seal	90682-Z310110-0000

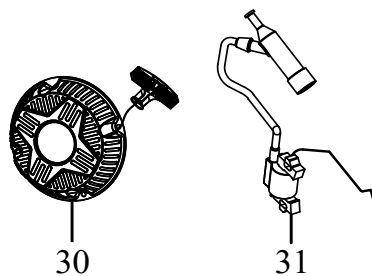

30. Recoil Assembly	28200-Z710210-R800
31. Ignition Coil Assembly	30400-Z190110-0000

COMMON ENGINE PARTS (CONTINUED)

Common Engine Parts (Continued)

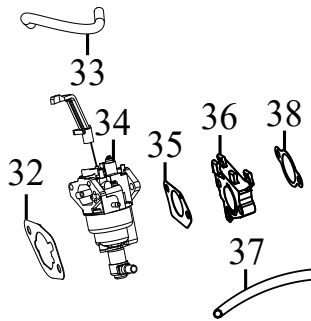

32. Air Filter/Carburetor Gasket	17001-Z080210-0000
33. Propane Feed Hose	30431-Y030110-0000
34. Carburetor	16100-Z0T0110-00A0
35. Carburetor/ Spacer Gasket	16001-Z100110-0000
36. Spacer Gasket	16003-Z100110-0000
37. Gasoline Feed Hose	90686-Z330110-0000
38. Spacer/Cylinder Gasket	17002-Z100110-0000

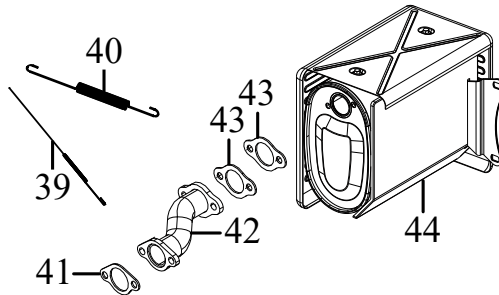

39. Throttle Return Spring	16012-Z080110-0000
40. Governor Arm Spring	16063-Z710110-00A0
41. Manifold/Cylinder Gasket	18001-Z190110-00A0
42. Manifold Pipe	18150-Z710110-0000
43. Manifold/Muffler Gasket	18001-Z080110-00A0
44. Muffler Assembly	18100-YEE0110-0000

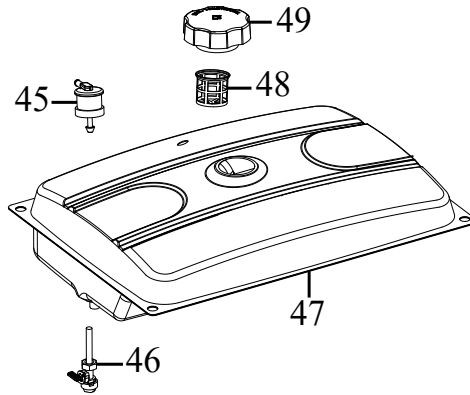

45. Breather Valve	15150-Y1Z0110-0000
46. Fuel Valve Assembly	16750-Y020210-0000
47. Fuel Tank	16620-YDK0110-R80P
48. Fuel Filter	16652-Y020120-00A0
49. Fuel Tank Cap	16730-Y020610-H700

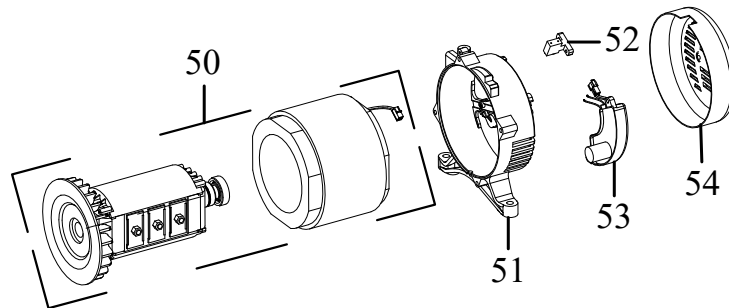

50. Stator and Rotor Assembly	31300-YEE0110-0000
51. Stator Support	30021-Y030310-0000
52. Brush Assembly	31320-Y030120-0000
53. AVR	31320-Y030120-0000
54. Stator End Cap	30022-Y030110-R800

COMMON ENGINE PARTS (CONTINUED)

Common Engine Parts (Continued)

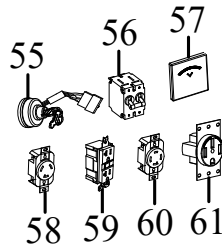

55. Key Switch Assembly	35160-Y030710-0000
56. Main Circuit Breaker	35627-YEE0110-0000
57. Voltage Meter	37114-Y280110-0000
58. 120V 30A Outlet	35614-Y4D0110-0000
59. 120V 20A GFCI Outlet	35614-Y600610-0000
60. 240V 30A Outlet	35614-Y4D0210-0000
61. 240V 50A Outlet	35614-Y400110-0000

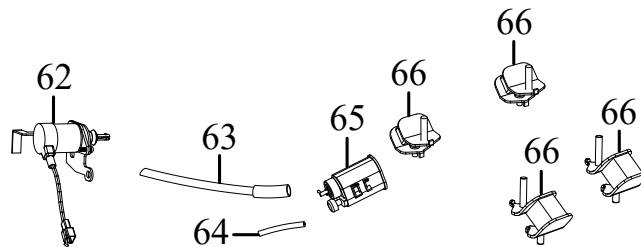

62. Idle Control Solenoid	35180-Z190120-0000
63. Fuel Tank/Carbon Box Hose	16804-YEZ0110-0000
64. Carbon Box/Air Filter Hose	16805-YEZ0110-0000
65. Carbon Box	16801-Y120110-0000
66. Motor Mounts	51012HY030120-0000

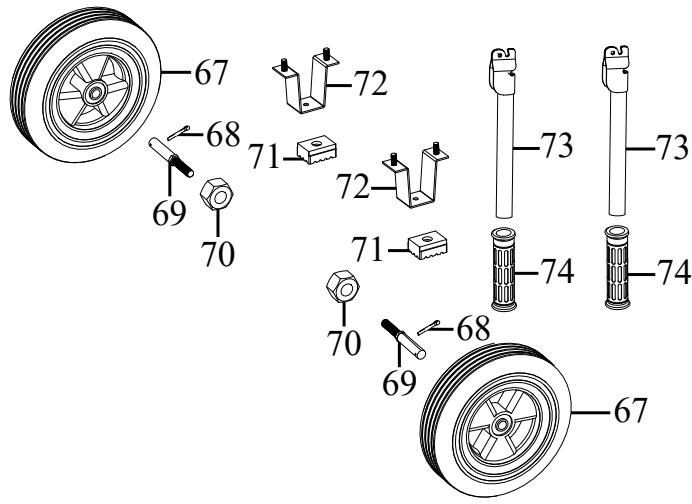

67. Wheel	44110-YDK0110-0000
68. Cotter Pin	90501-0436-01
69. Axle	44020-YDK0110-0100
70. Axle Nut	90332-Y110610-0000
71. Vibration Pad	51014HYDK0110-0000
72. Support Leg	51016-YDK0110-H600
73. Handle Assembly	54110-YDK0110-H600
74. Handle Grips	54101-Y020110-0000

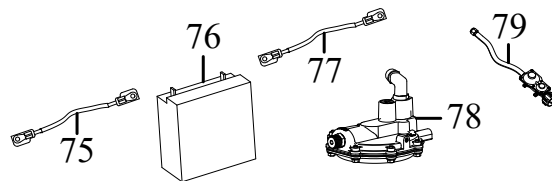

75. Positive Battery Cable	31114HY130310-0000
76. Battery	31110-Y9X0110-0000
77. Negative Battery Cable	31112HY130310-0000
78. 2nd Stage Propane Regulator	77100-Z0T0110-0000
79. Propane Regulator/Hose	77300-Z140110-0000

WIRING DIAGRAM

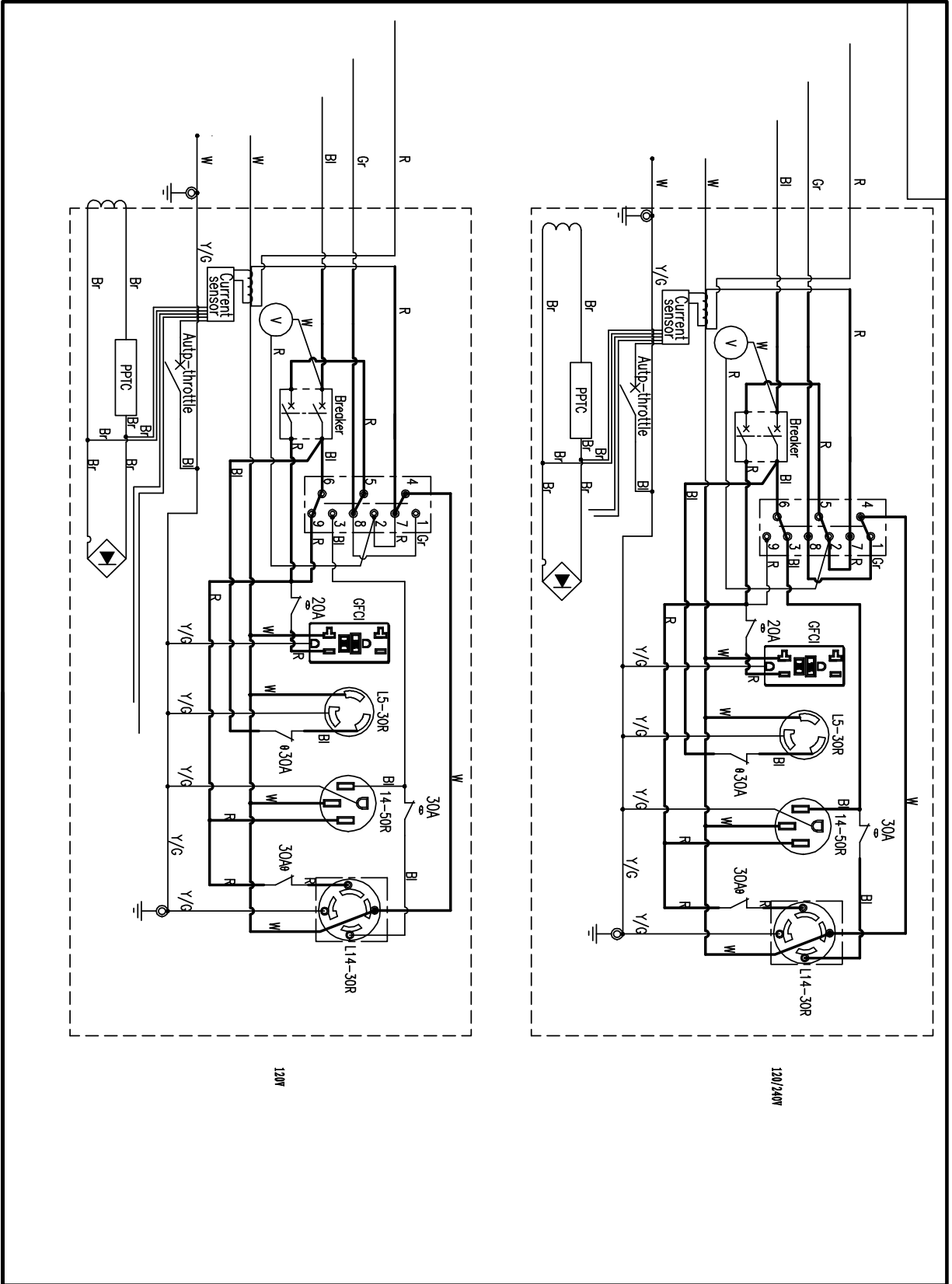



POWERING EVERYONE...
ANYWHERE!



5800 Ontario Mills Parkway
Ontario, CA 91764
United States

844-387-6629