

# Room CO2, Humidity and Temperature Sensor

with Zigbee 3.0 wireless communication



The Titan Products Zigbee Z3 CO2, Humidity and Temperature sensor is designed to wirelessly monitor the environmental conditions within a space and expose these parameters wirelessly via a Zigbee 3.0 network.

Ideal for office, retail, school or other commercial environments, the TPZRCO2HT-Z3 offers benefits such as:

- Drastically reduced install costs and timing due to the ability to remove cabling between sensors and controllers.
- Flexibility of sensor location with the sensor being battery driven and free from associated cabling.
- Accurate monitoring of temperature, CO2 and humidity levels allowing paired controllers to maintain comfortable conditions aiding productivity of the individuals within the space.

The CO2 sensor fully supports Automatic Background Calibration (ABC) to limit the effects of long term sensor drift. The transmissions from the TPZRCO2HT-Z3 room sensor are configured via the Min/Max reporting intervals and the configured COV (change of value) parameters set within the relevant measurement clusters.

The TPZRCO2HT-Z3 is supplied in a white IP20 enclosure as standard.

For more information on the TPZRCO2HT-Z3 please call the sales team on 0161 406 6480.

## Specification

Power Supply:	3.7V, 2600mAh lithium thionyl chloride battery (AA size)
Battery Life:	Up to 5 years (depending on transmission intervals and based on default settings)
Communications:	Zigbee 3.0
Transmission Frequency:	2.4GHz
Transmission Power:	8dBm
Transmission Range:	Up to 60m indoor (depending on building type) Up to 200m outdoor (line of sight)
Measured Range:	Temperature = 0 to 50°C Humidity = 0 to 100% CO2 = 0-2000ppm
Accuracy:	Temperature = +/- 0.5°C @ 25 °C Humidity = +/-2% CO2 = +/-50ppm + 2% of reading
Operating Temperature:	0 to 50°C
Operating Humidity:	5-80% Non-condensing.
Wireless Module Approvals:	FCC CFR 47 Part 15 DA00-1407 FCC Public Notice Radio: EN 300 328:V1.9.1 EMC: EN 301 489-17 V2.2.1 EMC: EN 62479 2010 EMC: EN 301 489-1 V1.9.2 Safety: EN 60950-1:2006
Approvals:	CE / RoHS / WEEE
Warranty Period:	24 months (excludes battery)
Enclosure:	UL L94-V0 flame retardant polycarbonate
Dimensions:	90mm high, 80mm wide, 29mm deep
Country of Origin:	UK
Product Code:	TPZRCO2HT-Z3

## CO2 Automatic Background Calibration (ABC)

ABC calibration is required to stabilise the CO2 measurement to achieve optimum accuracies. This is catered for via the ABC process.

The auto-calibration period within the sensor is set to perform every 24 hours after power up. After initial calibration, over time, the zero point of the sensor needs to be re-calibrated to maintain the long term stability of the sensor. In many applications, this can happen automatically using the built in auto-calibration function.

For the ABC function to operate correctly, it is important that the sensor is exposed to a low, unoccupied background CO2 level at least once during the auto-calibration period.

## Dimensions

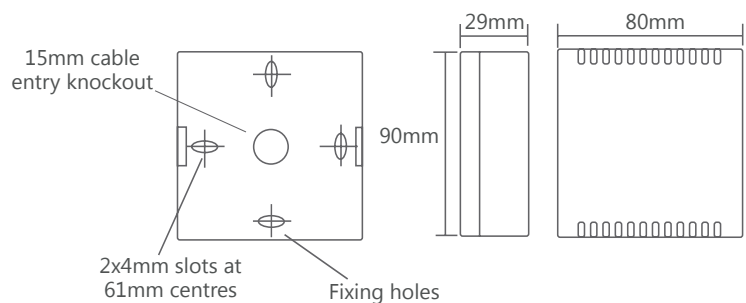

## Connections

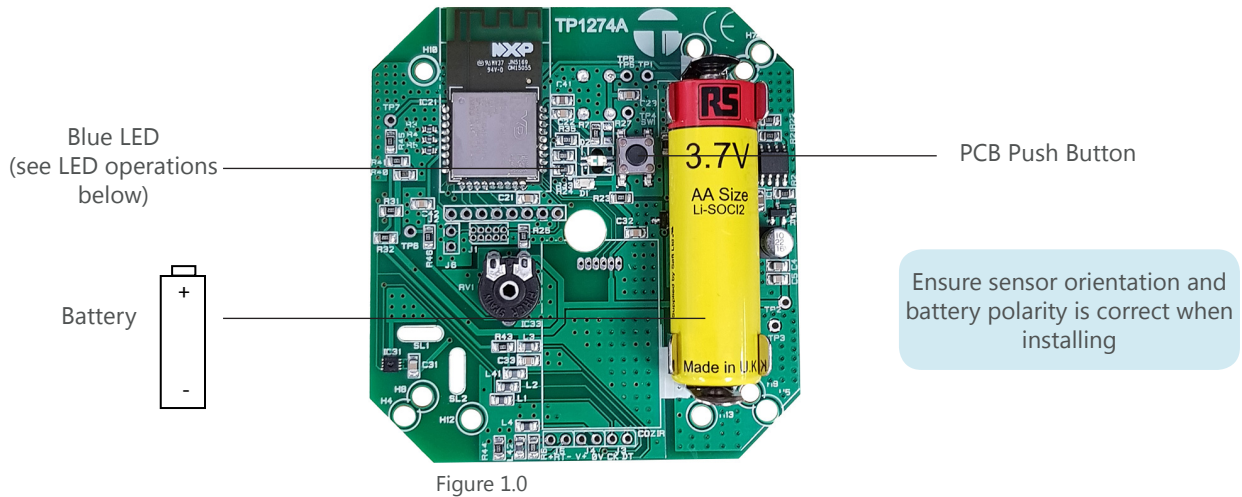

Figure 1.0

## LED Indication

Do not insert the sensor battery until the device is ready for commissioning and the WAC/Co-ordinator is powered up and available to pair with the wireless sensors.

If there are several sensors that need commissioning onto the same network then these should be powered up and paired one at a time.

When the sensor is initially powered up with the battery inserted it will be un-paired and the multi-colour LED will flash Red every second. This shows that the sensor is searching for an available network and attempting to join/re-join.

Implementing Base Device Behaviour (BDB), if no network is found after power up, the sensor will sleep for 60 seconds before attempting to search for an available network again to preserve battery life. This sleep pattern can be overridden off by selecting Keep Alive via the PCB push button sequence. See Blue LED indication table.

It is possible to force specific features within the sensor by holding the PCB push button and releasing at certain points of the BLUE LED sequence. To perform one of the below tasks, press and hold the PCB button, the LED will begin to flash every 0.5 second, release at the relevant point of the sequence to perform the associated task.

## Factory Reset

To reset an end device; remove the battery, press and hold the PCB push button down while re-inserting the battery. Once the battery is inserted, release the PCB push button.

Upon resetting, the device will restore the factory default settings for the minimum, maximum and delta change reporting along with the polling intervals. Once reset the device will search for strongest Zigbee 3.0 network and attempt to join as described above.

Blue LED Timing	Feature
Release after 1st LED flash	Force wake and poll parent for messages
Release after 2nd LED flash	Not Used
Release after 3rd LED flash	Keep Alive (sensor will flash every second to indicate sensor is operating in a Keep Alive state)
Release after 4th LED flash	Calibrate CO2 sensor to Fresh Air (Co2 sensor only)
Release after 5th LED flash	Initiate OTA update process

*Keep Alive mode ensures the devices is kept awake and inhibits sleep. If using Keep Alive for commissioning purposes please ensure Keep Alive is cancelled for normal operation to preserve battery life. To exit Keep Alive mode and revert to normal operation, press the PCB push button once.*

## Default and Recommended Settings

Setting	Factory Default	Range
Minimum Reporting Interval	60 seconds (Temperature and Humidity) 600 seconds (Co2)	0-65536 seconds
Maximum Reporting Interval	300 seconds (Temperature and Humidity) 600 seconds (Co2)	0-65536 seconds
Delta Change Reporting Threshold	Temperature = 0.5°C Humidity = 5% Co2 = 100ppm	N/A
Polling during normal operation	60 seconds	0-65536 seconds (Polling will match the Min Reporting Value)
Polling (accelerated) upon joining / re-joining network	Every 2 seconds for 60 seconds	N/A

## Supported End Points, Clusters & Attributes

Endpoint	Feature	Device ID	Name
EP1	Temperature	770	Temperature Sensor

Cluster ID	Cluster Attributes	Sever/Client
0x0000	Basic	Server
0x0001	Power Configuration	Server
0x0003	Identify	Server
0x0015	Commissioning	Server
0x0402	Temperature Measurement	Server
0x040D	Co2 Concentration Measurement	Server
0x0003	Identify	Client
0x0019	OTA	Client

Endpoint	Feature	Device ID	Name
EP2	Humidity	775	Humidity Sensor

Cluster ID	Cluster Attributes	Sever/Client
0x0000	Basic	Server
0x0001	Power Configuration	Server
0x0003	Identify	Server
0x0015	Commissioning	Server
0x0402	Relative Humidity Measurement	Server
0x040D	Concentration Measurement	Server
0x0003	Identify	Client

For a full breakdown of each attribute supported visit [www.titanproducts.com](http://www.titanproducts.com) and download the Zigbee 3.0 technical manual.

## Battery Information

Please make sure batteries are disposed of in accordance with EC Directive 2006/66/EC, amended by EU Directive 2008/12/EC or in line with your territory battery disposal guidelines.

It is important not to short-circuit, crush, disassemble, heat above 100°C, incinerate, or expose the batteries to water. Do not solder directly to the cell. The Recommended batteries for the Titan Products wireless sensors are 3.7V 2600mAh AA size Lithium-Thionyl Chloride. These are not rechargeable. All batteries should be stored in a clean, cool, dry and ventilated area. When installing or replacing a battery please make sure the polarity is correct. Batteries are not covered by the Titan Products product warranty.

## FCC Information

This device complies with Part 15 of the FCC Rules. Operation is subject to the following two conditions:

- (1) this device may not cause harmful interference
- (2) this device must accept any interference received, including interference that may cause undesired operation.

- The sensor is to be wall mounted at approx. 1.5m from floor level.
- The sensor should be mounted in an area representative on the environment to be measured and must be away from direct sunlight, draughts, window / door openings and heating / cooling sources.
- Ensure the sensor is installed in the correct orientation\*. See Fig. 1.0.
- The sensor should not be used outside of its operating temperature range of 0 to 50°C.
- The sensor should not be used outside of its operating humidity range of 5-80% RH.(non-condensing)
- The sensor is for indoor use only.
- The sensor is IP20 rated and should be used in environments where this is suitable. Where dust, water, moisture, chemical gasses and contaminant ingress is possible, an alternative product should be used.
- The sensor should be mounted using the fixing holes provided.
- The stated battery life is estimated based on Titan Products' recommended minimum, maximum, delta change reporting and polling settings.
- It is recommended that the battery is replaced during regular maintenance work.
- It is the responsibility of the buyer/installer to ensure the sensor is suitable for integration in to their ambient temperature monitoring system.
- The sensor is designed for the monitoring and transmission of ambient temperature, humidity and CO2 levels only.
- It is recommended that the receiving Zigbee Wireless controller should be set up to alarm if out of range conditions are transmitted by the sensor.
- Battery status clusters are available in the sensor device. These clusters should be used in a maintenance program to monitor when the battery needs replacing.
- It is the installer's responsibility to ensure a site survey is completed ensuring the sensor location is suitable for the environment to allow consistent and stable transmissions between the sensor(s) and receiving device. Repeaters may be required.
- It is the customer's/installer's responsibility to ensure the sensor standards are acceptable for the country or state the device is being installed within.
- Solvents in the air derived from sources such as paints, cleaning products and adhesives can have a detrimental impact on the sensor cell. All sensors should therefore be installed after the space has been decorated and any flooring fitted. The sensors should also be kept away from adhesives and should the housing require cleaning a dry non-solvent based product must be used. Do not spray any liquid or cleaning products directly onto the ventilated housing. Exposing the sensor to such solvents or moisture will invalidate the product warranty.