



## INSTRUCTION MANUAL

# **X-CALIBUR** PATENT # US 8240431 B2

**Mobile Fall Protection System**

### **Instruction Manual**

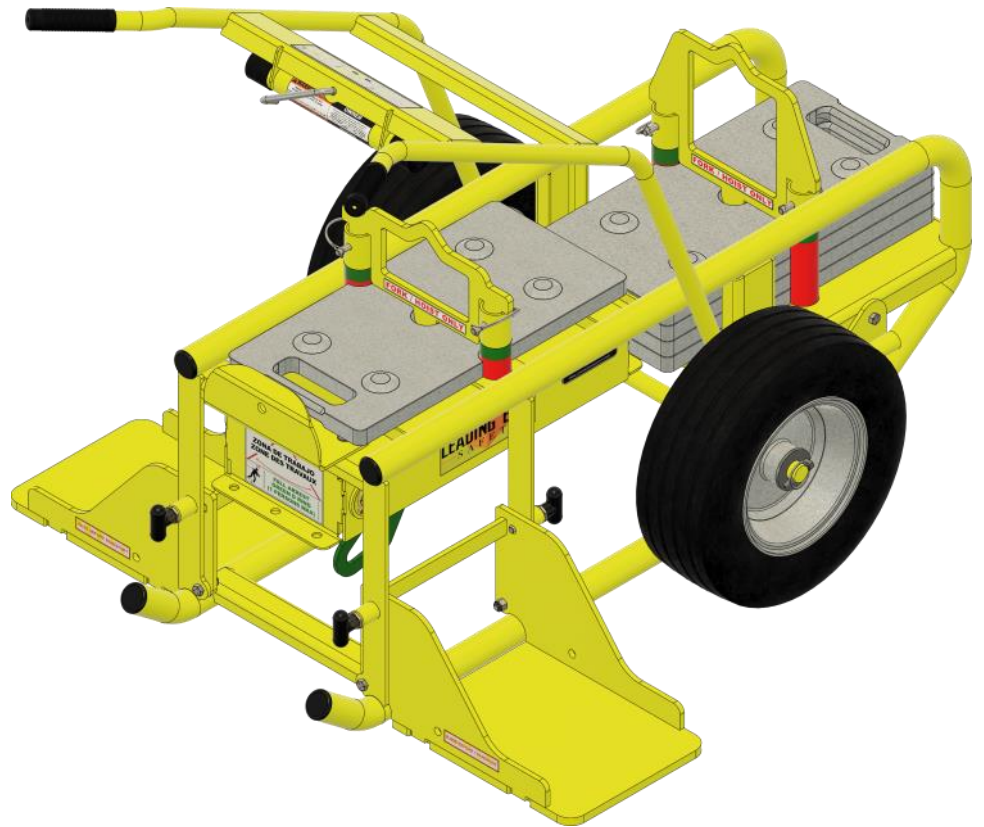

**\*WARNING\***

Serious injury or death may occur if this product is used for purposes other than designed. The manufacturer provides the following instructions for the use and care of this equipment. It is the responsibility of the purchaser to understand and convey explicit instruction to each user. The AES Manufacturing/Leading Edge Safety X-CALIBUR complies with the requirements of the Federal Occupational Safety and Health Administration (OSHA) when set up and used according to the manufacturers' instructions.

LIT ID: XBR-IM-23.0327

# X-CALIBUR INSTRUCTION MANUAL

## TABLE OF CONTENTS

### INTRODUCTION

Standards and Requirements_____	3
Models_____	4
Parts List_____	5

### GETTING STARTED

Applications_____	10
Definitions_____	10
Use & Limitations_____	11
Hoisting or Lifting_____	12
General Safety_____	12
Before Each Use_____	13
Positioning the Unit_____	13
Special Applications_____	15
Making Connections_____	15
Maintenance, Care & Storage_____	16
In The Event of A Fall_____	16

### APPENDIX

Appendix A - X-Calibur Engagement Box Removal & Installation_	17
Inspection & Maintenance Log_____	18

# X-CALIBUR INSTRUCTION MANUAL

E  
N  
G  
L  
I  
S  
H

## ***LEADING EDGE SAFETY, LLC*** **X-CALIBUR Instruction Manual**

Published by Leading Edge Safety, LLC  
North Kansas City, MO

### **X-CALIBUR COMPLETE MOBILE FALL PROTECTION SYSTEM**

Leading Edge Safety, LLC  
1345 Taney  
North Kansas City, MO 64116  
[www.LeadingEdgeSafety.net](http://www.LeadingEdgeSafety.net)

Copyright © 2023 by Leading Edge Safety, LLC

PRINTED IN THE UNITED STATES OF AMERICA

# X-CALIBUR INSTRUCTION MANUAL

## 1.0 Standards and Requirements

**1.1** The X-CALIBUR, manufactured by Leading Edge Safety LLC, is a dynamic anchor designed to dissipate the energy generated from a fall event into the surrounding substrate and arrest a fall. The X-CALIBUR is capable of supporting a Maximum Arresting Force (MAF) of 1,800lbs for up to (1) worker on approved substrates. Therefore, the X-CALIBUR is an acceptable component of a complete active fall arrest system and satisfies those requirements specified in: ANSI/ASSE Z359.6-2009 “Specifications and Design Requirements for Active Fall Protection Systems.”

**1.2** Let it be noted that this mobile fall protection anchorage unit shall only be used as part of a complete active fall protection system. Therefore, the following criteria must be met to satisfy ANSI/ASSE Z359.6-2009:

- 1.2a** Use of full body harness(s) in compliance with Z359.1-2007 “Safety Requirements for Personal Fall Arrest Systems, subsystems, and Components”
- 1.2b** Use of Lanyard(s) In compliance with Z359.13-2009 “Personal Energy Absorbers and Energy Absorbing Lanyards”
- 1.2c** Use of Connection(s) In compliance with Z359.12-2009 “Connecting Components for Personal Fall Arrest Systems”
- 1.2d** Use of Manufacturer’s Recommendations; the X-CALIBUR shall not be installed/positioned/utilized in a manner that violates the literature, instructions, technical bulletins or any other documentation produced by Leading Edge Safety LLC.
- 1.2e** Calculations by an authorized user (qualified person) to verify that the substrate, edge distance, free fall distance, and the number of workers attached to cart satisfies those requirements of ANSI Z359.6.
- 1.2f** The use of component(s) used in combination with the X-CALIBUR that are not covered by ANSI/ASSE Z359 will not result in an acceptable Active Fall Protection System.

**1.3** In addition to satisfying Z359.6, the X-CALIBUR is also in compliance with OSHA’s “Fall protection systems criteria and practices” (CFR › Title 29 › Subtitle B › Chapter XVII › Part 1926 › Subpart M › Section 1926.502). Section 1926.502(d)(15) requires that an anchor either support 5,000 pounds per employee attached or is used as part of a complete personal fall arrest system. Note that this anchorage unit is never intended to withstand a force of 5,000 lbs per user, but rather to be used as part of a complete personal fall arrest system. Determining if this complete personal fall arrest system can maintain a safety factor of at least (2) will require an authorized user to verify the above criteria.

# X-CALIBUR INSTRUCTION MANUAL

E  
N  
G  
L  
I  
S  
H

***X-CALIBUR XBR-0000-23***  
MOBILE FALL PROTECTION SYSTEM

**MODEL# XBR-0000-23**

**1-PERSON FALL ARREST**

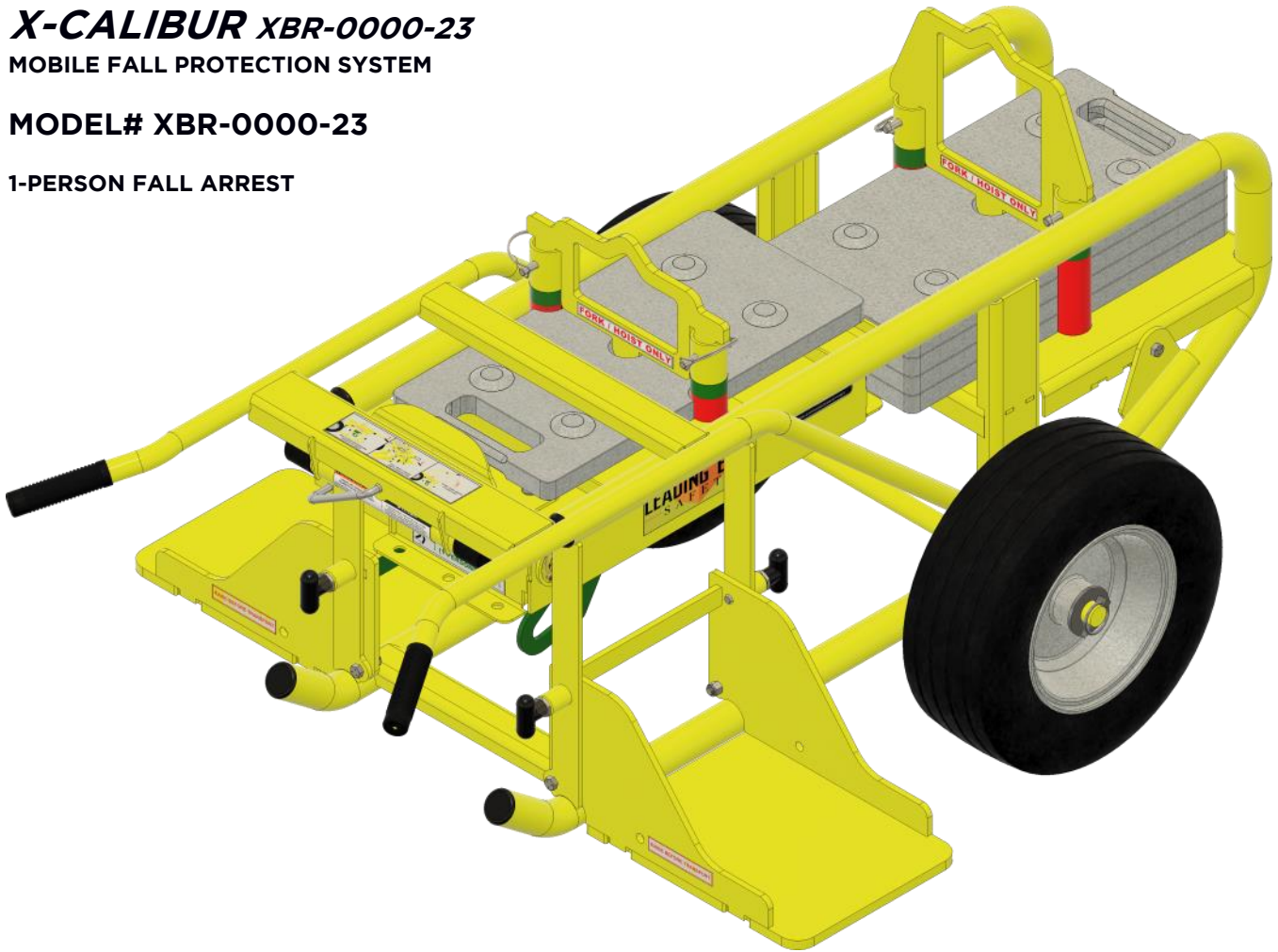

# X-CALIBUR INSTRUCTION MANUAL

1	X-CALIBUR FRAME ASSEMBLY	XBR-1000-23
2	X-CALIBUR HANDLE ASSEMBLY	XBR-2000-23
3	X-CALIBUR OUTRIGGER ASSEMBLY	XBR-3000-23
4	X-CALIBUR ENGAGEMENT BOX ASSEMBLY	XEBA-000-23
5	FLAT-FREE TIRE	T-18-8.50-8-SP
6	UNIVERSAL WEIGHT	UCW-000-23
7	FRONT LIFTING POINT/HOLD DOWN	SBR-5001-23
8	REAR LIFTING POINT/HOLD DOWN	XBR-5001-23
9	WIRE-LOCK CLEVIS PIN	SNAP-375-2250R
10	1" FLAT WASHER	W-1-FLT-ZC
11	3/16" x 1-1/4" LUNCH PIN	LP-187-1312
15	HAND GRIP 1" X 5"	HG-1
16	TUBE PLUG 1-5/8"	1_58TUBINGPLUG
17	SPRING LOADED T-HANDLE PIN	CP-K100TLO
18	1/2-13 x 1-1/2" HEX BOLT	B-12[_5]-13-1_5
19	1/2-13 NYLON-INSERT LOCKNUT	N-NL-12[_5]-13
20	HANDLE LOCK STRIKE PLATE	XBR-2501-23
29	WARNING-HANDLE OPERATION	LAB-XBR-002-23
31	WARNING-RAISE TRANSPORT	LAB-XBR-004-23

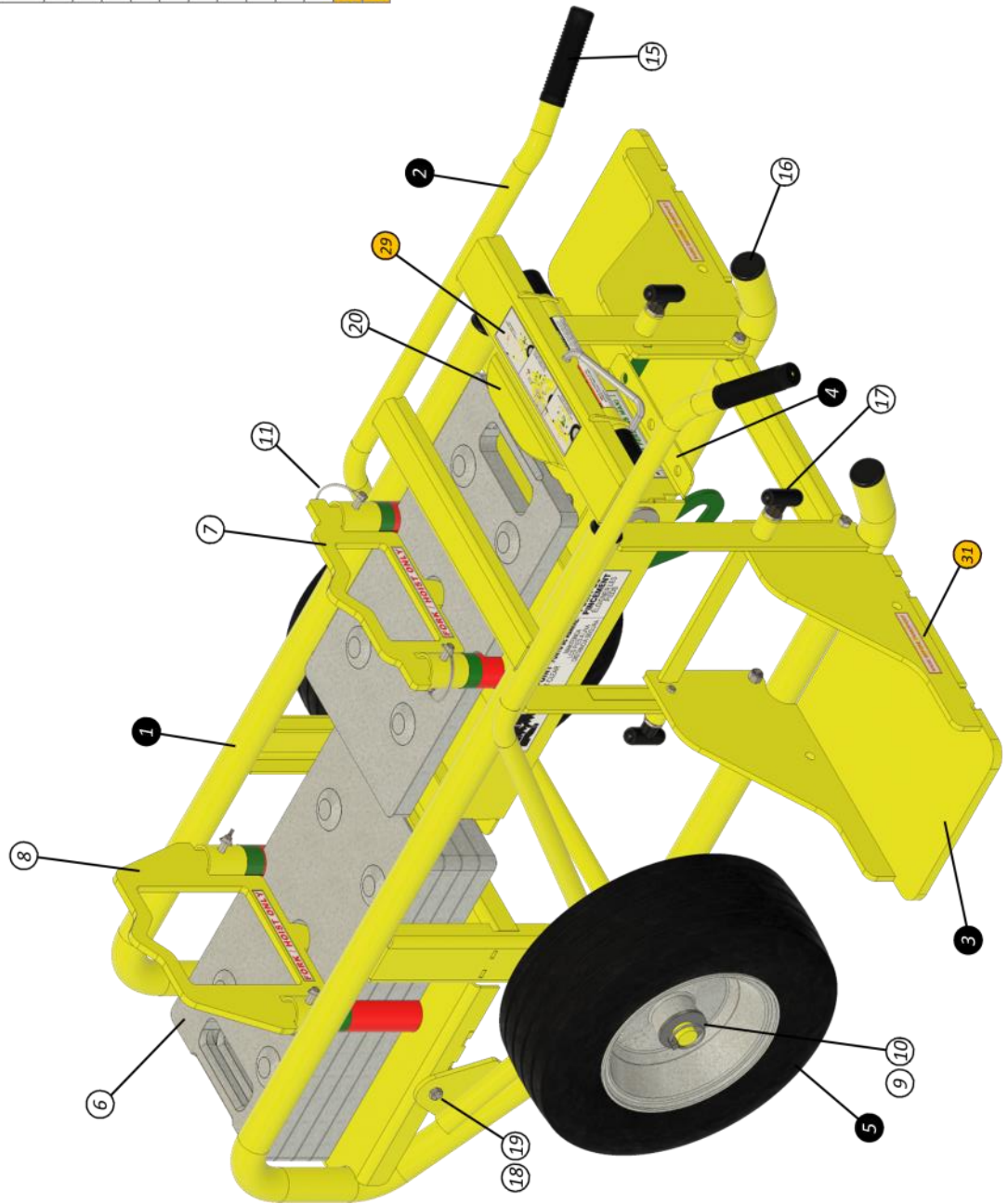

# X-CALIBUR INSTRUCTION MANUAL

1	X-CALIBUR FRAME ASSEMBLY	XBR-1000-23
2	X-CALIBUR HANDLE ASSEMBLY	XBR-2000-23
3	X-CALIBUR OUTRIGGER ASSEMBLY	XBR-3000-23
4	X-CALIBUR ENGAGEMENT BOX ASSEMBLY	XEBA-000-23
5	FLAT-FREE TIRE	T-18-8.50-8-SP
6	UNIVERSAL WEIGHT	UCW-000-23
8	REAR LIFTING POINT/HOLD DOWN	XBR-5001-23
10	1" FLAT WASHER	W-1-FLT-ZC
11	3/16" x 1-1/4" LUNCH PIN	LP-187-1312
14	TUBE CAP	VC-1625-1500
15	HAND GRIP 1" X 5"	HG-1
16	TUBE PLUG 1-5/8"	1_58TUBINGPLUG
17	SPRING LOADED T-HANDLE PIN	CP-K100TLO
20	HANDLE LOCK STRIKE PLATE	XBR-2501-23
21	HANDLE LOCK ASSEMBLY	XBR-2151-23
23	X-CALIBUR LOGO DECAL	LAB-XBR-005-23
25	WARNING-WORK ZONE DECAL	LAB-XEB-001-23
27	WARNING-FORK HOIST DECAL	LAB-SBR-003-23
28	WARNING-INSTRUCTION DECAL	LAB-JB-002-09c
30	WARNING-LOWER USE	LAB-XBR-003-23

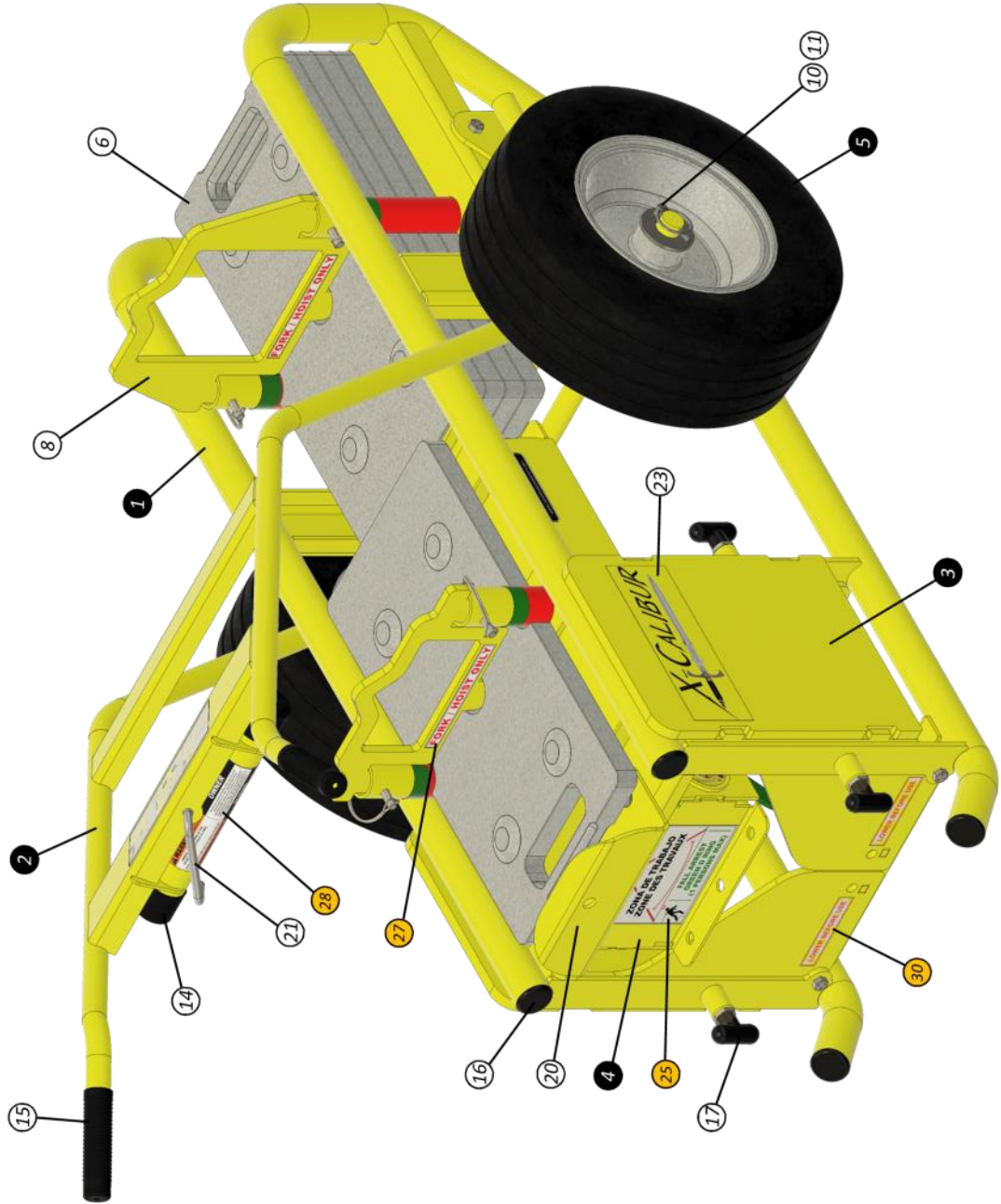

# X-CALIBUR INSTRUCTION MANUAL

E  
N  
G  
L  
I  
S  
H

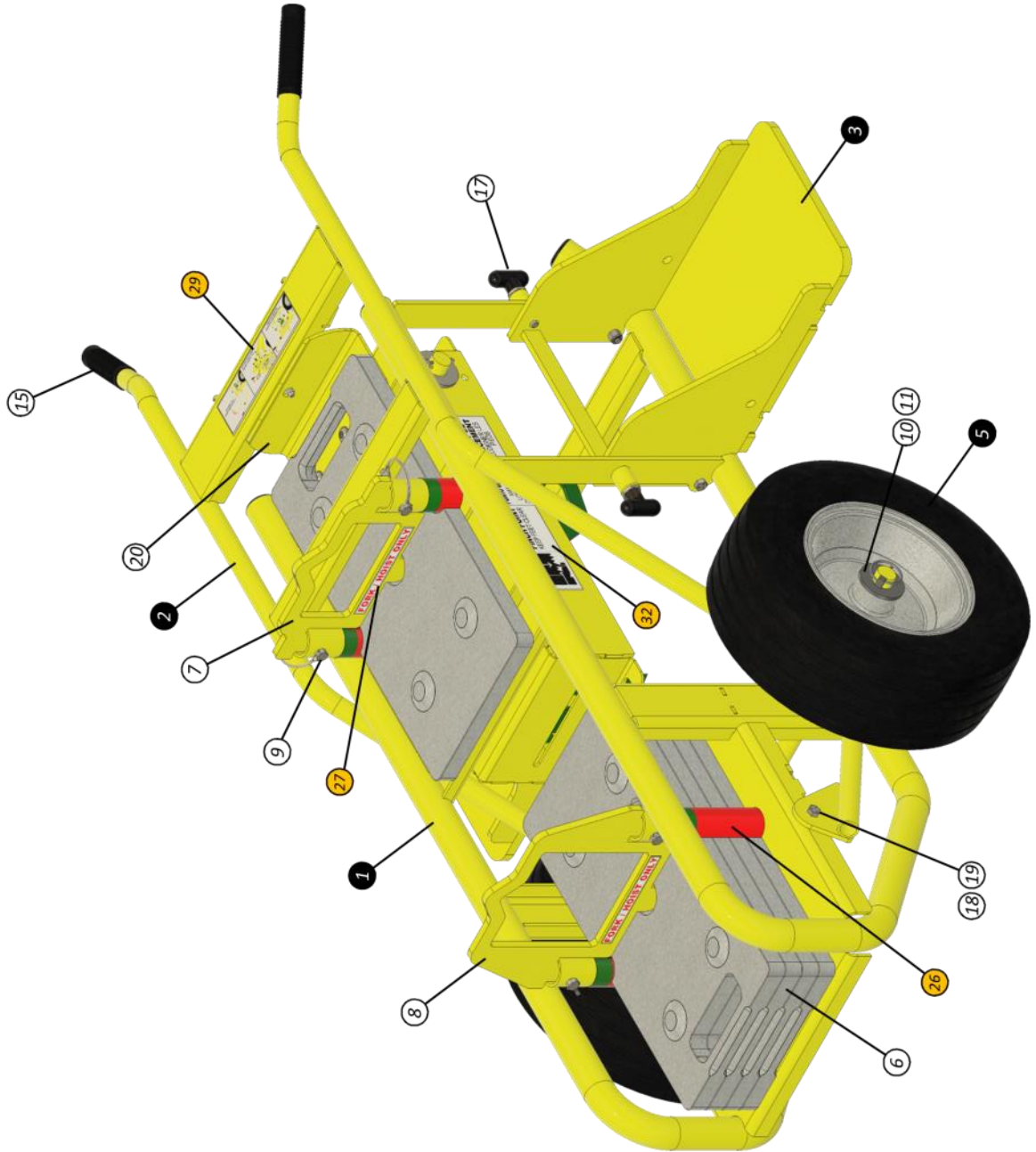

1	X-CALIBUR FRAME ASSEMBLY	XBR-1000-23
2	X-CALIBUR HANDLE ASSEMBLY	XBR-2000-23
3	X-CALIBUR OUIJRIGGER ASSEMBLY	XBR-3000-23
5	FLAT-FREE TIRE	T-18-8.50-8-SP
6	UNIVERSAL WEIGHT	UCW-000-23
7	FRONT LIFTING POINT/HOLD DOWN	SBR-5001-23
8	REAR LIFTING POINT/HOLD DOWN	XBR-5001-23
9	WIRE-LOCK CLEVIS PIN	SNAP-375-2250R
10	1" FLAT WASHER	W-1-FLT-ZC
11	3/16" x 1-1/4" LINCIN PIN	LP-187-1312
15	HAND GRIP 1" X 5"	HG-1
17	SPRING LOADED T-HANDLE PIN	CP-K100TLO
18	1/2-13 x 1-1/2" HEX BOLT	B-12(L5)-13-1_5
19	1/2-13 NYLON-INSERT LOCKNUT	N-NL-12(L5)-13
20	HANDLE LOCK STRIKE PLATE	XBR-2501-23
26	WARNING-WEIGHTS DECAL	LAB-SBR-002-23
27	WARNING-FORK HOIST DECAL	LAB-SBR-003-23
29	WARNING-HANDLE OPERATION	LAB-XBR-002-23
32	WARNING-PINCH POINT	LAB-G-001-09



# X-CALIBUR INSTRUCTION MANUAL

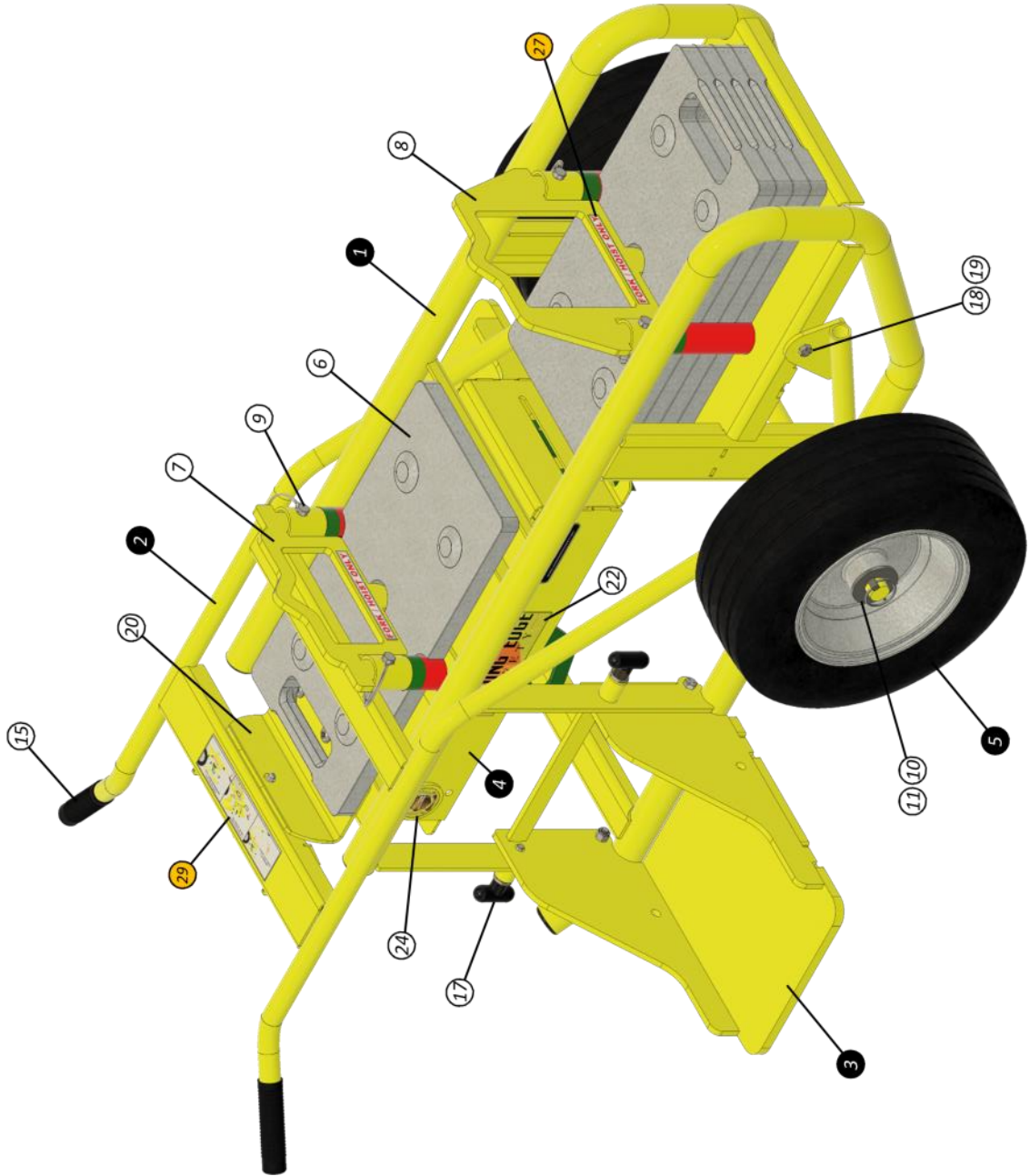

1	X-CALIBUR FRAME ASSEMBLY	XBR-1000-23
2	X-CALIBUR HANDLE ASSEMBLY	XBR-2000-23
3	X-CALIBUR OUTRIGGER ASSEMBLY	XBR-3000-23
4	X-CALIBUR ENGAGEMENT BOX ASSEMBLY	XEBA-000-23
5	FLAT-FREE TIRE	T-18-8.50-8-SP
6	UNIVERSAL WEIGHT	UCW-000-23
7	FRONT LIFTING POINT/HOLD DOWN	SBR-5001-23
8	REAR LIFTING POINT/HOLD DOWN	XBR-5001-23
9	WIRE-LOCK CLEVIS PIN	SNAP-375-2250R
10	1" FLAT WASHER	W-1-FLT-ZC
11	3/16" x 1-1/4" LYNCH PIN	LP-187-1312
15	HAND GRIP 1" X 5"	HG-1
18	1/2-13 x 1-1/2" HEX BOLT	B-12(L5)-13-1_5
19	1/2-13 NYLON-INSERT LOCKNUT	N-NL-12(L5)-13
20	HANDLE LOCK STRIKE PLATE	XBR-2501-23
22	LEADING EDGE LOGO DECAL	LAB-LE-001-23
24	PATENT DECAL	LAB-PAT-1
27	WARNING-FORK HOIST DECAL	LAB-SBR-003-23
28	WARNING-INSTRUCTION DECAL	LAB-JB-002-09c
29	WARNING-HANDLE OPERATION	LAB-XBR-002-23

# X-CALIBUR INSTRUCTION MANUAL

E  
N  
G  
L  
I  
S  
H

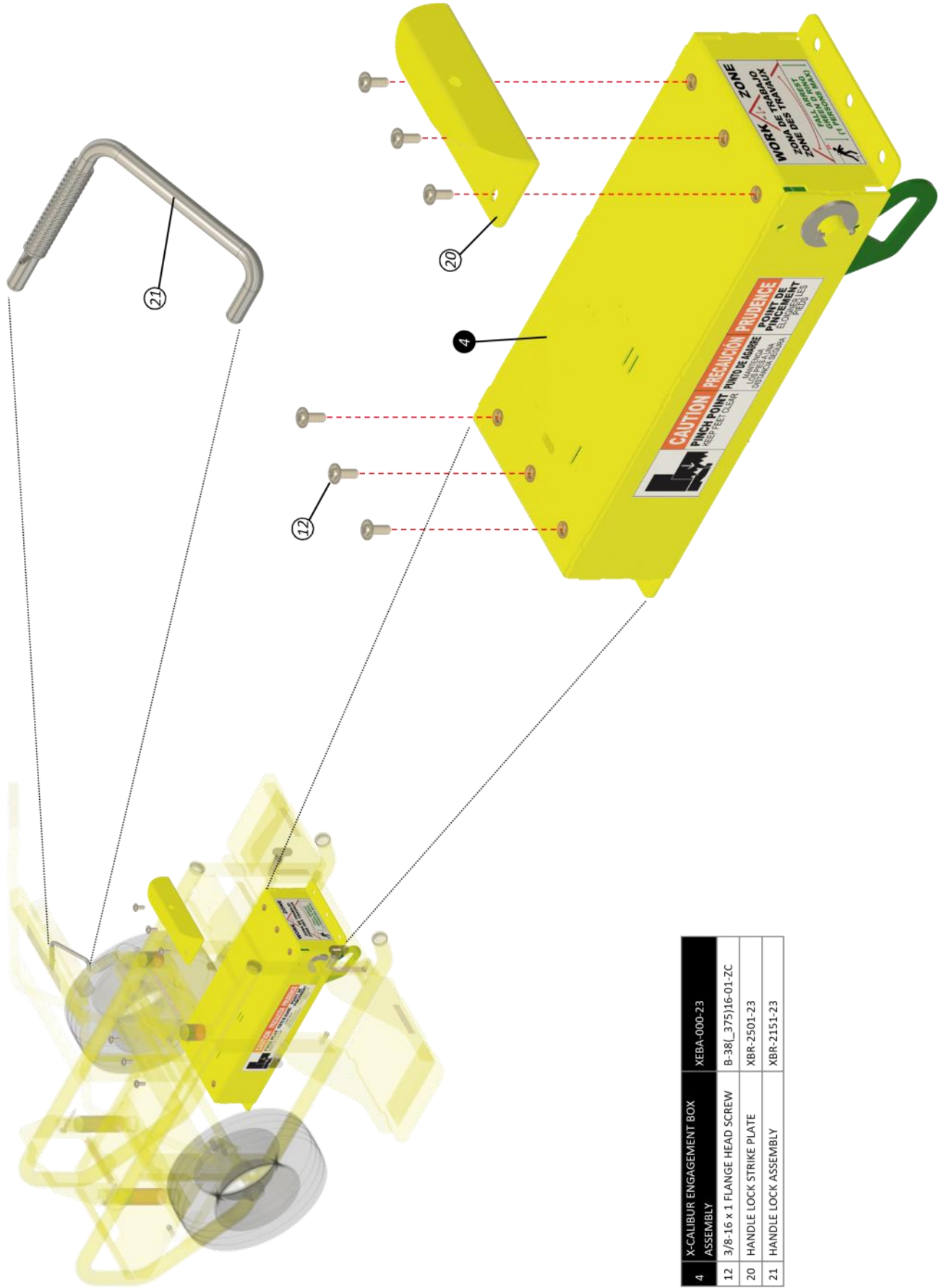

4	X-CALIBUR ENGAGEMENT BOX ASSEMBLY	XEBA-000-23
12	3/8-16 x 1 FLANGE HEAD SCREW	B-38(L375)16-01-ZC
20	HANDLE LOCK STRIKE PLATE	XBR-2501-23
21	HANDLE LOCK ASSEMBLY	XBR-2151-23

# X-CALIBUR INSTRUCTION MANUAL

## 2.0 APPLICATIONS

- 2.1 The X-CALIBUR is designed to be used as an anchorage as part of a complete mobile fall protection system. The X-CALIBUR may be used where worker mobility and fall protection are required. See [WWW.OSHA.GOV](http://WWW.OSHA.GOV) for all regulations and standards.
- 2.2 The X-CALIBUR allows for up to one worker to be tied-off for fall arrest to the *Fall Arrest Attachment Point*. See the following definitions (Section 3.0):

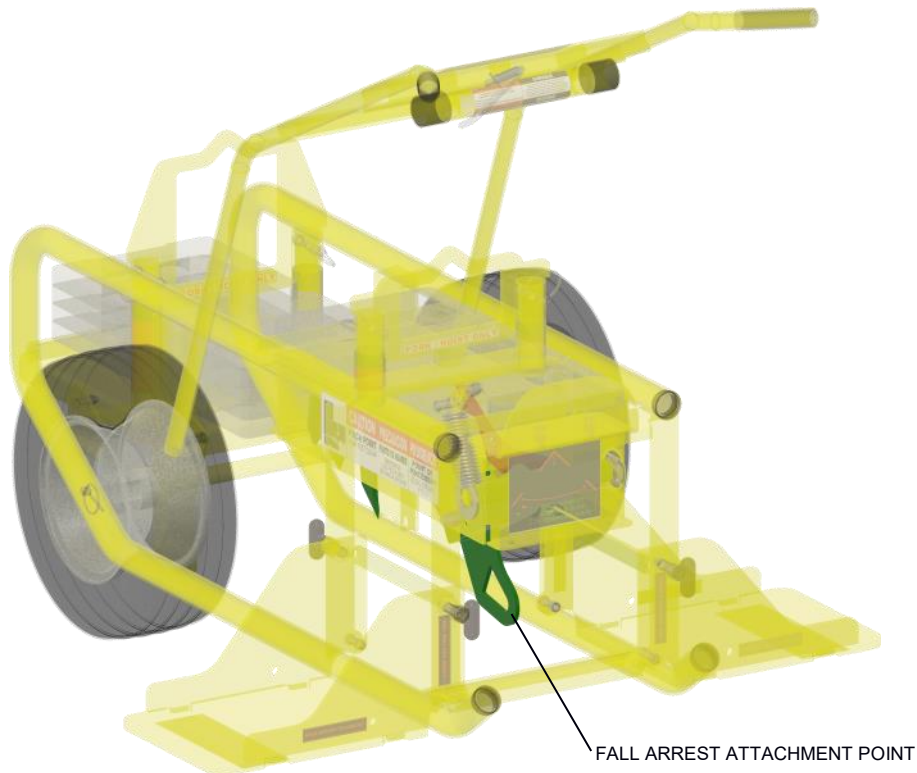

## 3.0 DEFINITIONS:

- 3.1 **Fall Restraint System** – A fall restraint system (FRS) *prevents* the user from falling. The system is comprised of a body harness along with an anchorage, connectors and other necessary equipment. The components typically include a lanyard and also may include a lifeline and other devices. The X-CALIBUR shall not be used as an anchorage in a fall restraint system.
- 3.2 **Personal Fall Arrest System** – A personal fall arrest system (PFAS) arrests a fall *after* a fall has begun. The system is comprised of an anchorage, connectors, and a body harness and may include a deceleration lifeline, or suitable combinations. Note that a PFAS does NOT prevent a fall from occurring. The X-CALIBUR can be used as an anchorage in a PFAS for up to one worker. A Personal Fall Arrest System must meet the following OSHA requirements:
  - Limit maximum arresting force on an employee to 1,800 pounds when used with a body harness;
  - Be rigged so that an employee can neither free-fall more than 6 feet (1.8 meters) nor contact any lower level;
  - Bring an employee to a complete stop and limit maximum deceleration distance an employee travels to 3.5 feet (1.07 meters); and
  - Have sufficient strength to withstand twice the potential impact energy of an employee free-falling a distance of 6 feet (1.8 meters) or the free-fall distance permitted by the system, whichever is less.
- 3.3 **Anchorage** — An anchorage is a secure point of attachment for lifelines, lanyards, or deceleration devices. The X-CALIBUR can be used as an anchorage for fall arrest.

# X-CALIBUR INSTRUCTION MANUAL

ENGLISH

## 4.0 USE AND LIMITATIONS

**4.1 LOAD REQUIREMENTS**—Before the X-CALIBUR is hoisted to any roof surface, the user must verify that the deck assembly can accommodate the live load requirements of the X-CALIBUR.

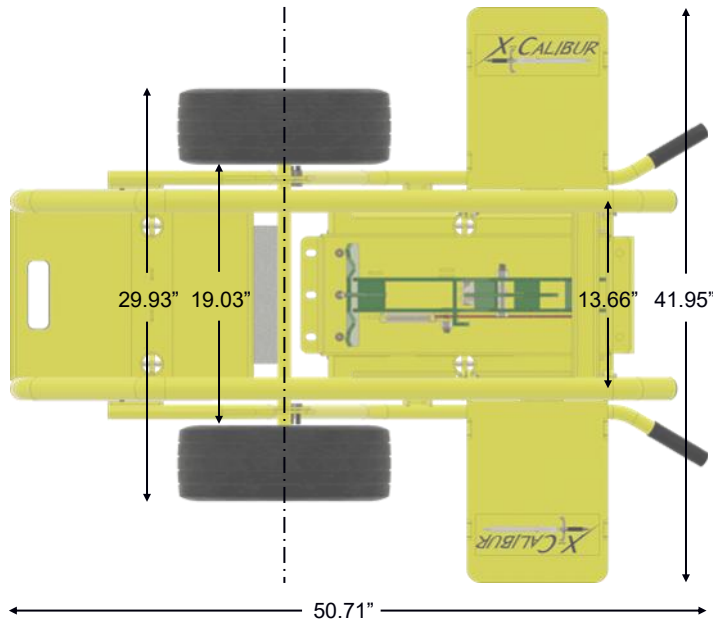

Approximate Unit Weight: 572 lbs  
 Tire Footprint: 2.5" x 4.75"  
 Outrigger Footprint: 10.25" x 13.25"  
 Approximate Weight per Footprint: 143.00 lbs  
 Approximate Pounds per SqIn: 1.94 psi

## 4.2 APPROVED SUBSTRATES:

BUILT-UP ROOFING (BUR)<sup>1</sup>  
 THERMOPLASTIC POLYOLEFIN (TPO)<sup>1</sup>  
 POLYVINYL CHLORIDE (PVC)<sup>1</sup>  
 BUILT-UP ROOFING (BUR) AND GRAVEL<sup>1</sup>  
 ROOF COATINGS<sup>1</sup>

MODIFIED BITUMEN<sup>1</sup>  
 ETHYLENE PROPYLENE DIENE MONOMER (EPDM)<sup>1</sup>  
 BALLASTED SINGLE-PLY MEMBRANES<sup>1</sup>  
 INVERTED ROOF MEMBRANE ASSEMBLY (IRMA)<sup>1</sup>

FLAT SURFACES AND UP TO 2:12 SLOPE.

### **DO NOT USE THE X-CALIBUR ON THE FOLLOWING SUBSTRATES:**

ICE  
 SNOW  
 UNFINISHED ROOF ASSEMBLIES

<sup>1</sup> WHEN MECHANICALLY FASTENED OR ADHERED AS PART OF A COMPLETE ROOF ASSEMBLY AND TOTAL FINISHED ROOF ASSEMBLY IS GREATER THAN 3.875". FIG 4-1

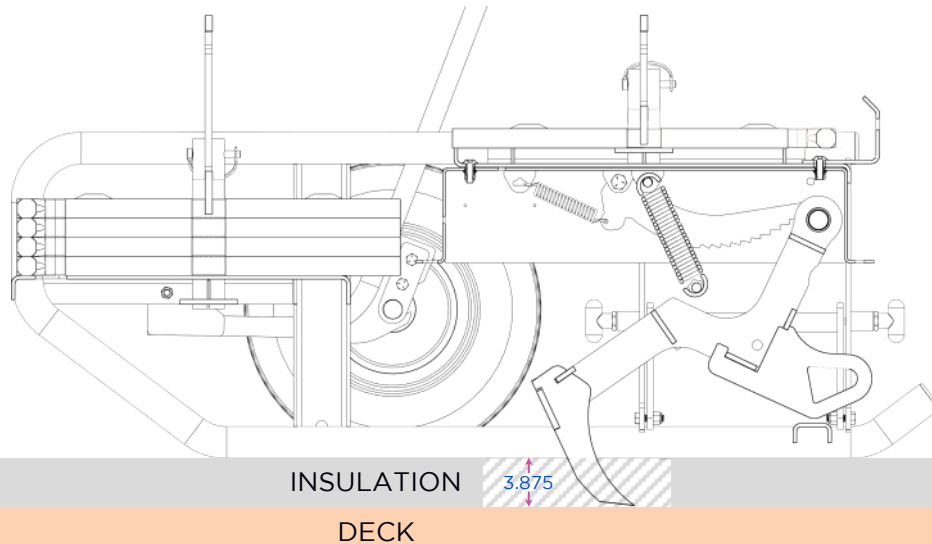
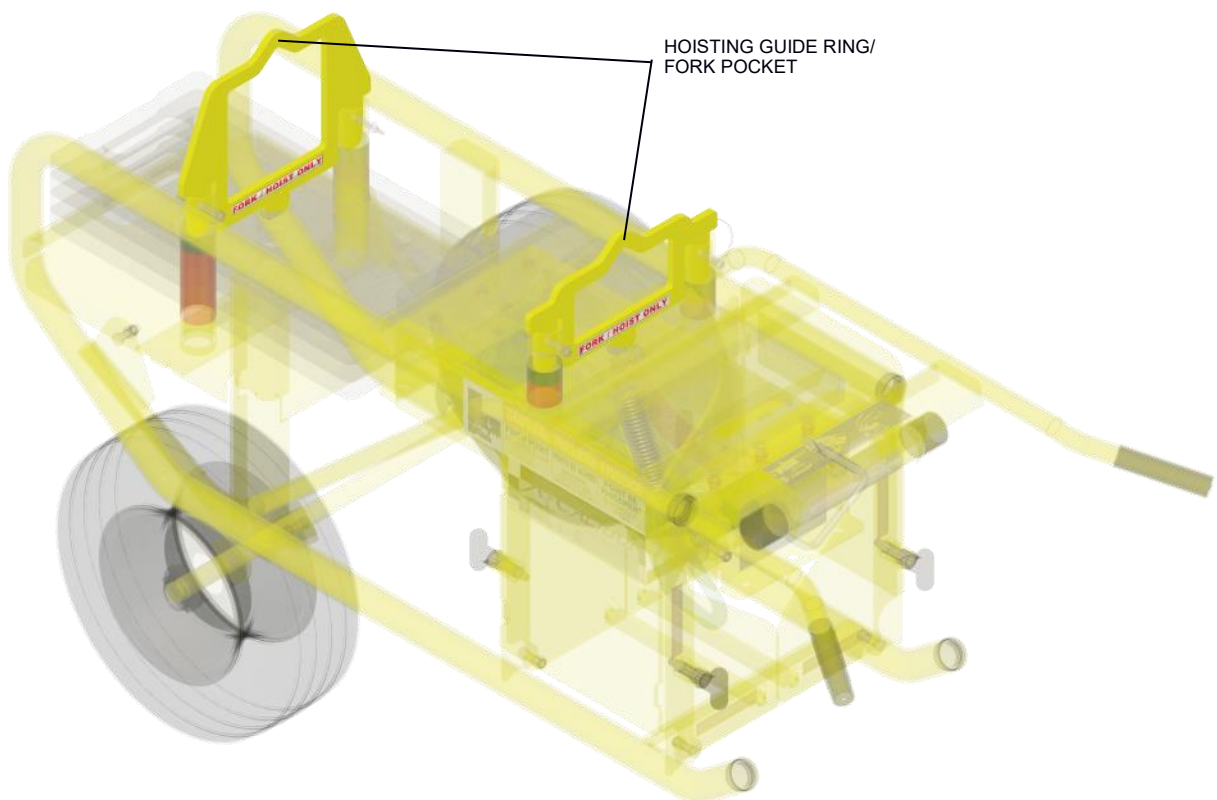

**FIG. 4-1**

# X-CALIBUR INSTRUCTION MANUAL

## 5.0 HOISTING OR LIFTING

- 5.1 Loads may slip or fall if the X-CALIBUR is not hoisted or lifted properly and may result in injury or death.
- 5.2 Never hoist or lift the X-CALIBUR if any of the hoisting rings/fork pockets are damaged.
- 5.3 Never hoist or lift the X-CALIBUR with unsecured materials on the unit.
- 5.4 Ensure any auxiliary equipment is properly and securely attached to the X-CALIBUR before hoisting or lifting.
- 5.5 Ensure Hoisting Guide Ring/Fork Pockets are secured with Wire-Lock Clevis Pins before hoisting or lifting.
- 5.6 The X-CALIBUR shall be hoisted or lifted following good industry practices, State and Federal Regulations, and hoisting and lifting equipment manufacturer's guidelines.
- 5.7 The X-CALIBUR was designed to be hoisted by a crane or lifted by a forklift and is equipped with dual purpose hoisting guide rings/fork pockets.



## 6.0 GENERAL SAFETY

- 6.1 **USE COMMON SENSE!** Most accidents can be avoided by using common sense and focusing on the job at hand.
- 6.2 The X-CALIBUR should not be used by persons whose ability or alertness is impaired by fatigue, intoxication, prescription or illegal drugs, or any other physical or mental cause that may expose the user or others to injury.
- 6.3 Always wear proper Personal Protective Equipment.
- 6.4 Keep hands and feet clear of moving parts including the Engagement Arm.
- 6.5 Do not use the equipment near electrical lines.
- 6.6 Do not allow passengers to ride on the safety cart.
- 6.7 Do not use on wet, slippery or icy substrates.

# X-CALIBUR INSTRUCTION MANUAL

ENGLISH

## 6.0 GENERAL SAFETY (Continued)

- 6.8 Only use the X-CALIBUR on completed roof assemblies for which it has been tested. (Reference Sect 4.2 Approved Substrates)
- 6.9 Always lower the unit using the locking handle so the frame is resting on the substrate when not in use.
- 6.10 Always use caution and common sense when moving the unit. Additional workers may be needed to safety move the unit when additional materials, tools or equipment have been added to the unit.

## 7.0 BEFORE EACH USE

7.1 Before using this unit, a rescue plan and procedure in accordance with OSHA Standards must be in place to ensure prompt rescue in the event of a fall.

7.2 Inspect the unit for any damage. A maintenance log has been provided in this manual that may be copied and used to track inspections and damage.

7.2.A Check for loose, bent or damage parts, including the talon and rake tips of the engagement arm. FIG 7-2

7.2.B Check welded connections for visible distortion, cracks or other damage.

7.2.C Check Attachment Point for distortion or damage.

7.2.D Ensure all safety labels are present and fully legible. (Reference parts list pages 5-9)

7.2.F Ensure the Engagement Arm Locking Mechanism is in the proper spring loaded position using the viewing window. FIG 7-2-F

7.2.G **DO NOT USE DAMAGED EQUIPMENT OR EQUIPMENT THAT HAS BEEN MODIFIED.**

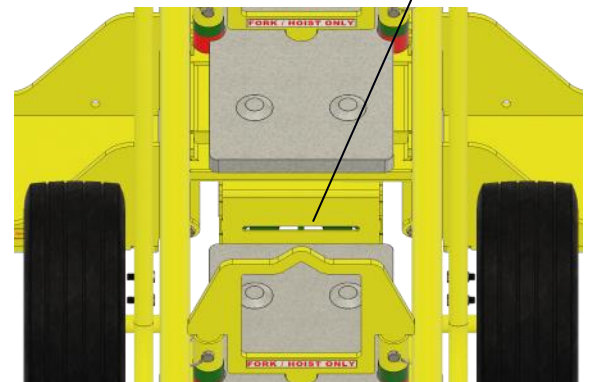
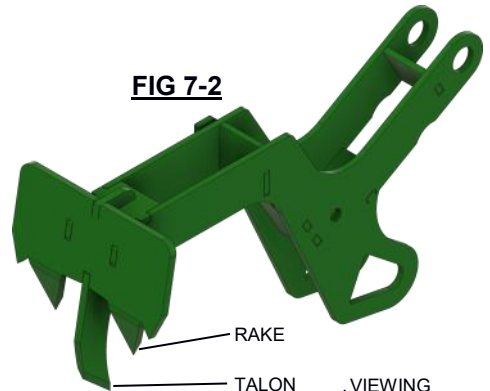

FIG 7-2-F

## 8.0 POSITIONING THE UNIT

8.1 Verify that the substrate the unit is to be used on is acceptable (Reference Sect 4.2 Approved Substrates) and the entire working surface has the strength and structural integrity to safely support both the workers and the unit.

8.2 Position the unit with the Fall Arrest Attachment Point side 12' - 15' away and parallel to the working edge to maximize the work zone. FIG 8-2a

The unit may be used a minimum of 4' from the leading edge, maintaining a maximum work zone of 45° or 2' from the center of the attachment point. FIG 8-2b

The unit may be used a maximum of 30' from the leading edge, however the work zone may not exceed 15' from the center of the attachment point. FIG 8-2b

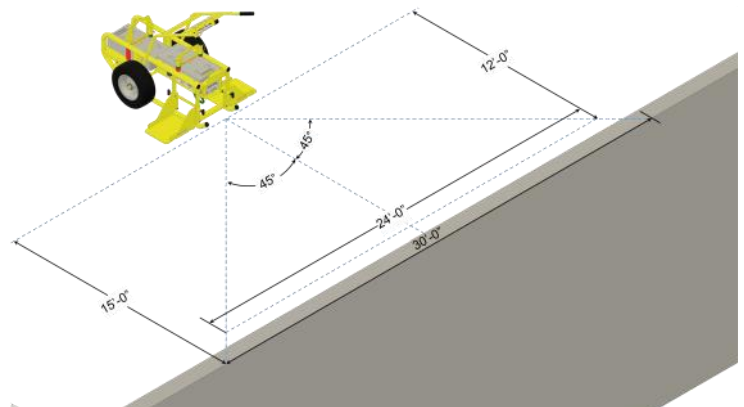

# X-CALIBUR INSTRUCTION MANUAL

## 8.0 POSITIONING THE UNIT (Continued)

**FIG 8-2b**

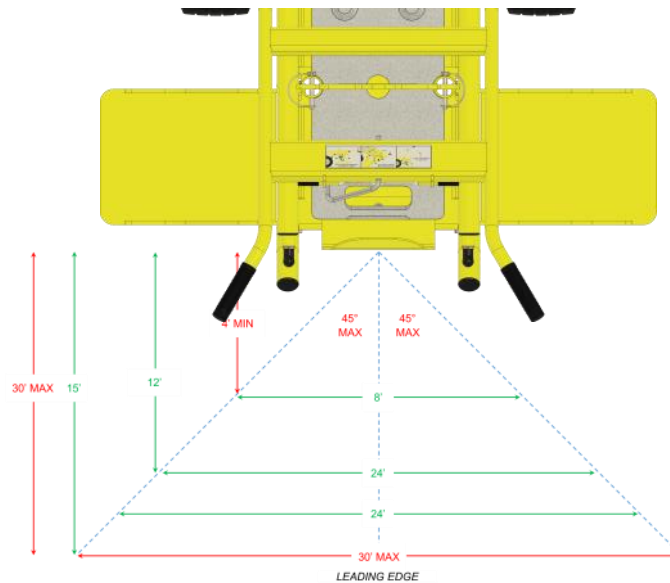

**8.3** Once the unit is properly positioned, ensure rear axle is parallel to the leading edge, raise the handle to lower the frame to the substrate, and deploy the outriggers. FIG 8-3

**8.3.A** To lower the X-CALIBUR frame to the 'frame down, brake position', apply & maintain pressure on the handle with one hand.

**8.3.B** While maintaining handle pressure with one hand, use your other hand to pull the locking pin out and release the handle.

**8.3.C** Slowly raise the handle to lower the X-CALIBUR frame to rest securely on the substrate in the 'brake position'.

**8.3.D** Pull T-Handle Pins to unlock and release outriggers, lower outriggers to the substrate until T-Handle Pins lock the outriggers in the deployed position.

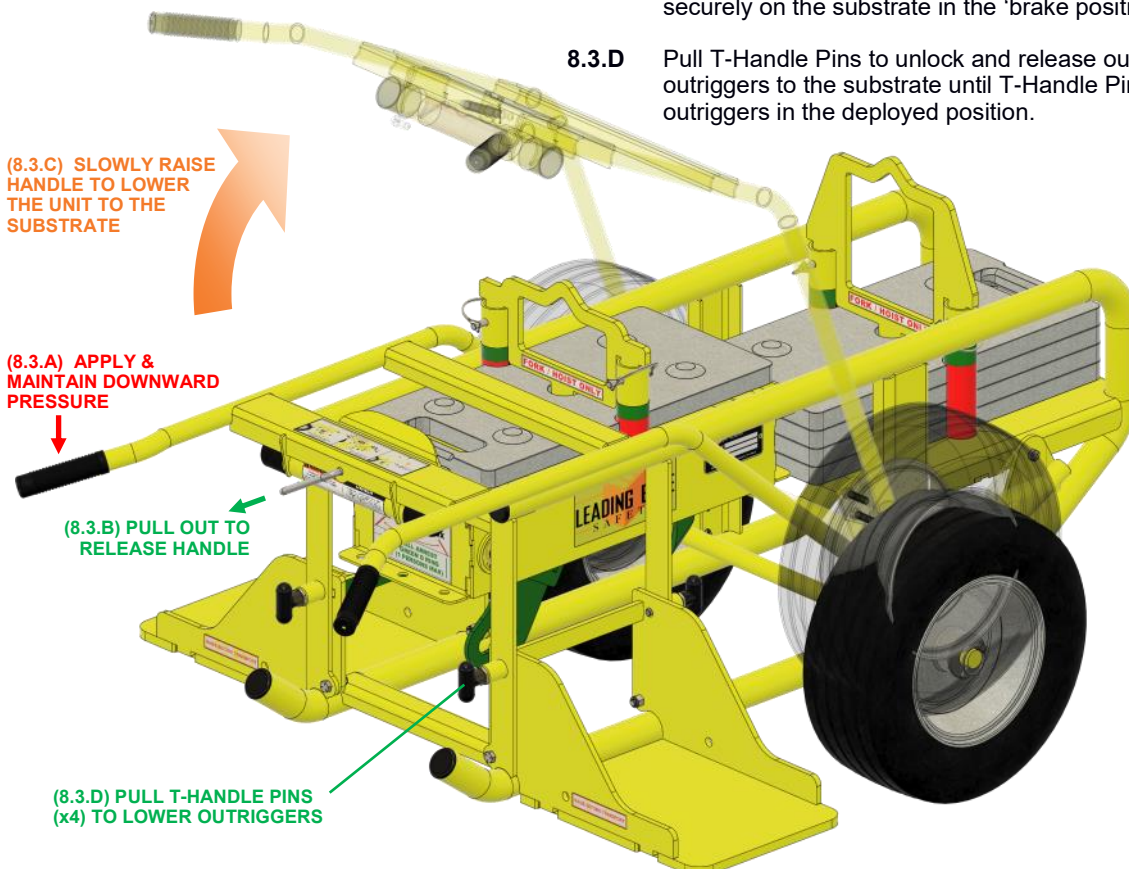

**FIG 8-3**

# X-CALIBUR INSTRUCTION MANUAL

## 9.0 SPECIAL APPLICATIONS

### 9.1 DISSIMILAR HEIGHT WALKING/WORKING SURFACES

**9.1.A** The X-CALIBUR may be used for fall arrest in dissimilar height applications where worker(s) are located on a surface lower than the surface the X-CALIBUR is positioned on and when properly set up and used with an SRL ANSI approved for leading edge conditions. FIG 9-1

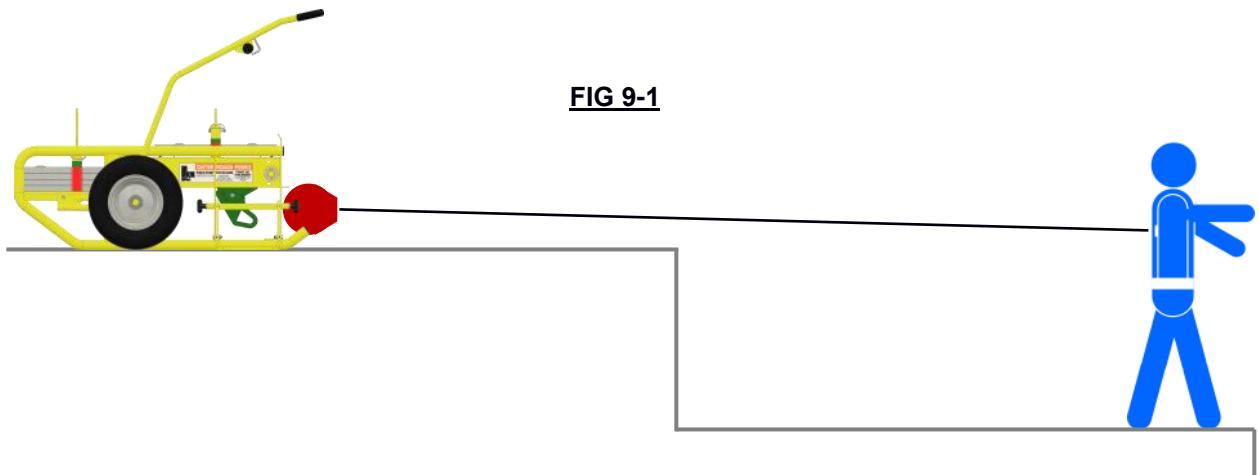

## 10.0 MAKING CONNECTIONS

**10.1** SRL's and lifelines shall only be connected to the 1-Ring Fall Arrest Attachment Points or to Fall Restraint D-Rings. FIG 10-1

**10.2** Only use self-locking snap hooks and self-locking carabiners when connecting SRL and lifelines to the X-CALIBUR. Only use connectors that are suitable to each application. Ensure connections are compatible in size, shape and strength. Do not use equipment that is not compatible with the X-CALIBUR connection points.

**10.4** Ensure that all connections are fully closed, locked and secure prior to use.

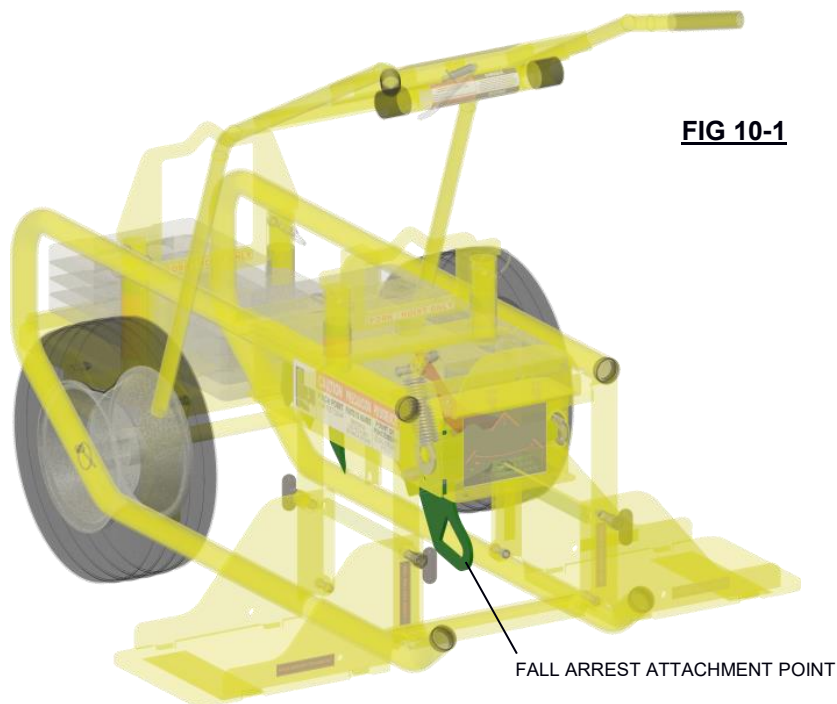



# X-CALIBUR INSTRUCTION MANUAL

## 11.0 MAINTENANCE, CARE & STORAGE

- 11.1 If the Engagement Arm has been activated by a fall, the Engagement Box Assembly (4) must be replaced before using the unit in fall arrest. Refer to assembly drawings for the location and part number and Appendix A for replacement instructions.
- 11.2 Keep tires free from build up and debris. Asphalt or adhesive build up on the tires can cause the unit to function improperly.
- 11.3 Inspect all bolts, pins, springs, welds and paint for visible damage. Damaged or missing parts can prevent the X-CALIBUR from working properly.
- 11.4 Maintain the paint finish to prevent corrosion. Use rust inhibitive paint compatible with the powder coat finish.
- 11.5 Store the X-CALIBUR in a place protected from the weather. Vinyl Weather Covers are available for long-term outdoor storage. Contact your local distributor or Leading Edge Safety for pricing and availability.
- 11.6 Rotate the tires or block the axles to avoid flat spots on the tires during long-term storage.

## 12.0 IN THE EVENT OF A FALL

- 12.1 Call 911 and report the fall emergency immediately.
- 12.2 Follow your company policy and site-specific rescue plan.
- 12.2 Before attempting to rescue a fall victim connected to the X-CALIBUR, ensure the X-CALIBUR is stable with the claw engaged into the substrate, both tires, and outriggers are contacting the walking/working surface.
- 12.3 Rescuers should attach themselves in fall restraint to a secondary mobile fall cart not involved in the fall or other certified anchor point before attempting to rescue a fall victim.
- 12.4 Once a fall victim has been recovered, the X-CALIBUR may be disengaged from the substrate. Use caution when disengaging the unit, keep hands and feet clear of moving parts and pinch points. In some cases, the Talon may become wedged into the substrate; to disengage the Talon from the substrate, unbolt the Engagement Box Assembly. Alternatively, use a wooden or metal beam to apply leverage against the underside of the frame to pry the unit free from the substrate, then remove the Engagement Box Assembly for return and replacement. FIG A-1
- 12.5 Remove the unit from fall arrest service by appropriate lock out/tag out procedures until the Engagement Box Assembly has been replaced.

# X-CALIBUR INSTRUCTION MANUAL

E  
N  
G  
L  
I  
S  
H

## APPENDIX A— X-CALIBUR ENGAGEMENT BOX ASSEMBLY REMOVAL & INSTALLATION

In the event of a fall or any damage to Engagement Box Assembly (XEBA-000-23) or it's associated components, the Engagement Box Assembly must be replaced before returning the unit to service.

### **STEP 1**

Remove the front Lifting Point (7) and Universal Weight (6)

### **STEP 2**

Remove the six 3/8-16 x 1" Flange Head Screws (12)

### **STEP 3**

Remove the X-CALIBUR Engagement Box Assembly

### **STEP 4**

Return the damaged Engagement Box Assembly to Leading Edge Safety:

Leading Edge Safety, LLC  
1400 Taney St  
North Kansas City, MO 64116  
888-990-2990

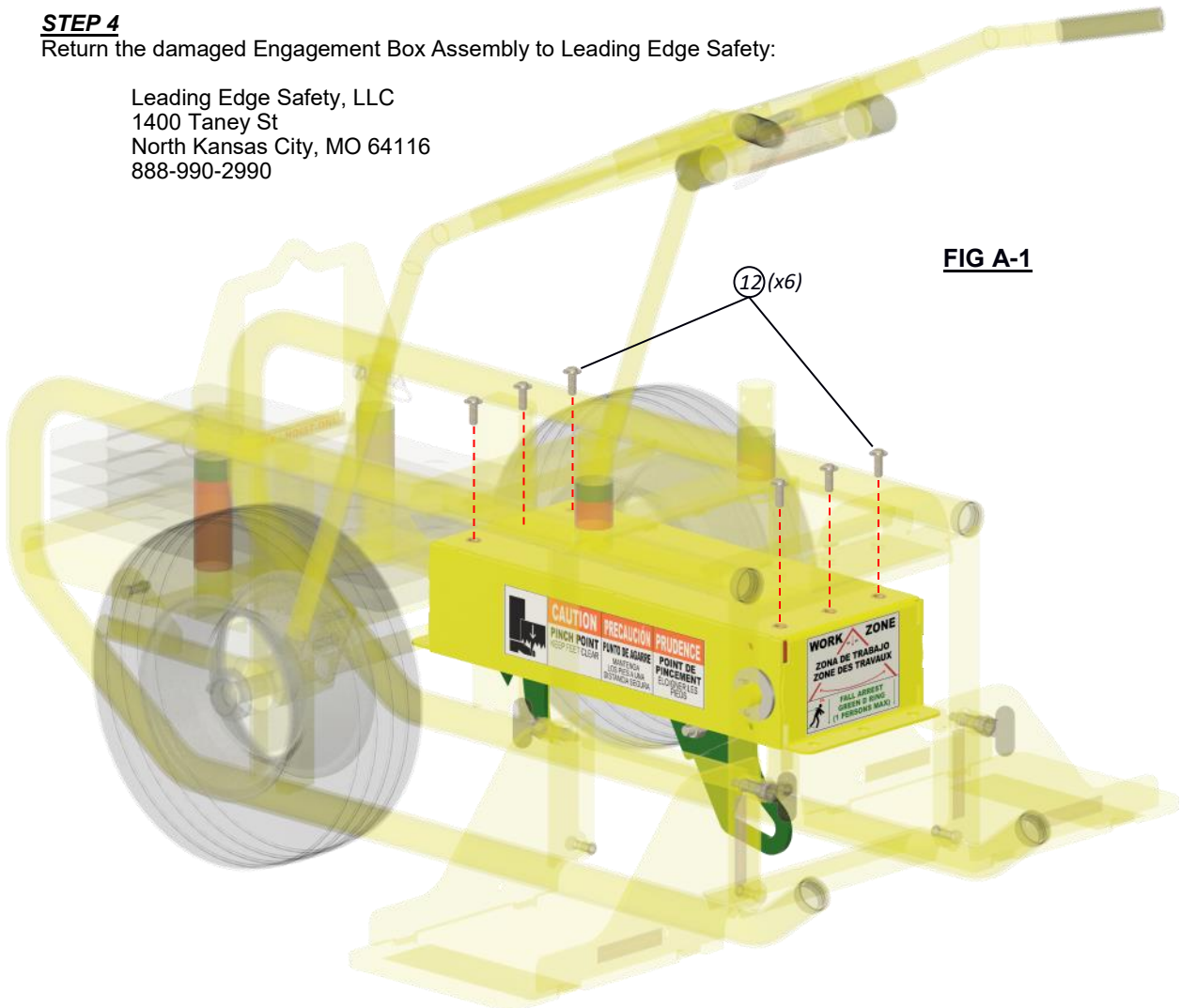

### **STEP 5**

Install new X-CALIBUR Engagement Box Assembly with Fall Arrest Tie Off Ring facing away from the rear tires as shown above.

### **STEP 6**

Secure the Engagement Box Assembly with six 3/8-16 x 1" Flange Head Screws (12)

**Once the new X-CALIBUR Engagement Box Assembly, Universal Weight, Lifting Point, and associated fasteners are all properly installed, the X-CALIBUR may be returned to service for fall arrest applications.**

# X-CALIBUR INSTRUCTION MANUAL

E  
N  
G  
L  
I  
S  
H

## MOBILE FALL CART INSPECTION AND MAINTENANCE LOG

PLEASE COPY THIS LOG, FILL IT OUT BEFORE EACH USE, AND KEEP IT IN YOUR RECORDS.

EQUIPMENT MODEL #: \_\_\_\_\_

EQUIPMENT SERIAL #: \_\_\_\_\_

DATE OF PURCHASE: \_\_\_\_\_

INSPECTION DATE: \_\_\_\_\_

Inspection Item	Corrective Action Needed?		Maintenance Performed
Overall Cart Parts	Yes	No	_____
			_____
Inspected By: _____			_____
Welded Connections	Yes	No	_____
			_____
Inspected By: _____			_____
Attachment Point Rings and Hoisting Rings	Yes	No	_____
			_____
Inspected By: _____			_____
Engagement Box Assembly	Yes	No	_____
			_____
Inspected By: _____			_____
Engagement Arm Freely Moving	Yes	No	_____
			_____
Inspected By: _____			_____
Warning Labels	Yes	No	_____
			_____
Inspected By: _____			_____
Overall Cart Corrosion	Yes	No	_____
			_____
Inspected By: _____			_____



Copyright © 2023 by Leading Edge Safety, LLC  
1345 Taney, North Kansas City, MO 64116  
[www.LeadingEdgeSafety.net](http://www.LeadingEdgeSafety.net)

PRINTED IN THE UNITED STATES OF AMERICA