

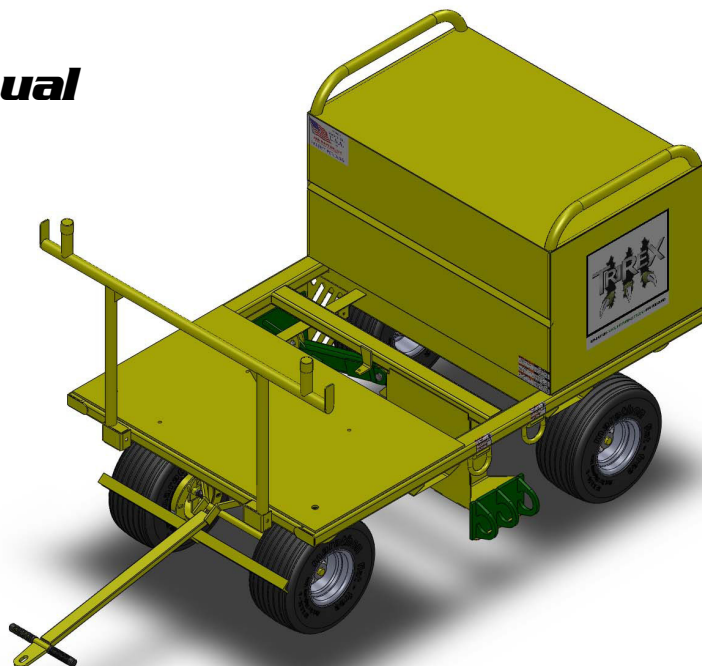

AES RAPTOR **TRI REX™** PATENT PENDING

Mobile Fall Protection System Anchorage Unit

Instruction Manual **(English Only)**



WARNING

Serious injury or death may result if this product is used for purposes other than designed. The manufacturer provides the following instructions for the use and care of this equipment. It is the responsibility of the purchaser to understand and convey explicit instruction to each user. The AES Raptor TriRex™ complies with the requirements of the Federal Occupational Safety and Health Administration (OSHA) when set up and used according to the manufacturers' instructions.

AES RAPTOR TriRex™ INSTRUCTION MANUAL

**E
N
G
L
I
S
H**

AES Raptor, LLC - Raptor TriRex™ Instruction Manual

Published by AES Raptor, LLC, North Kansas City, MO

AES RAPTOR COMPLETE MOBILE FALL PROTECTION SYSTEM
is a registered trademark of
AES Raptor, LLC
1349 Taney
North Kansas City MISSOURI 64116
www.raptorsafety.com

Copyright © 2010 by AES Raptor, LLC

PRINTED IN THE UNITED STATES OF AMERICA

AES RAPTOR TRIREX™ INSTRUCTION MANUAL

DIAGRAM OF PARTS

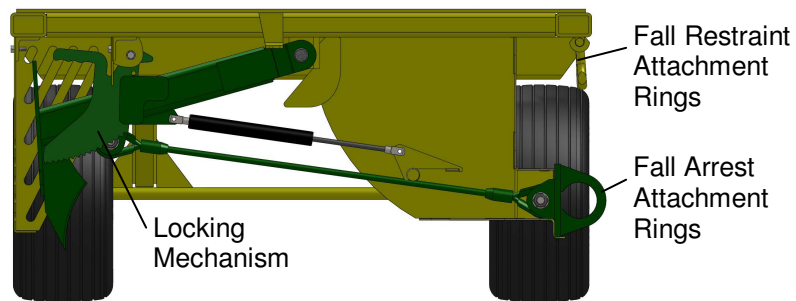
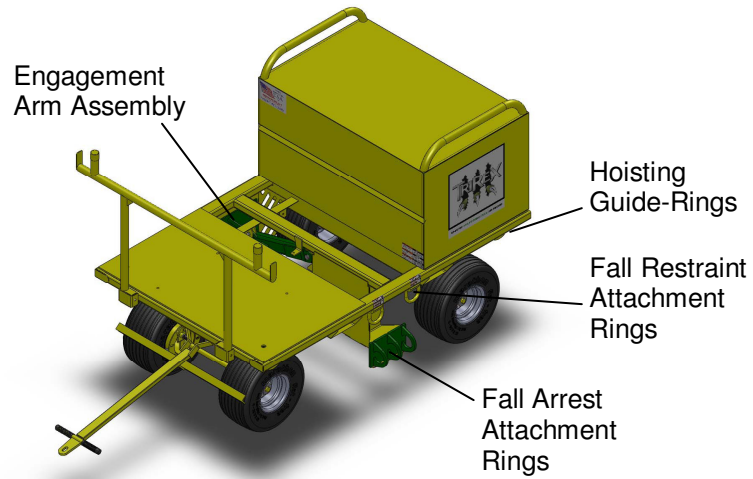

Patent Pending

1.0 ASSEMBLY

After unpacking the Raptor TriRex, bolt the cart handle to the yoke with the provided 5/8 x 2" bolts and 5/8" nylon locking nuts. Refer to the Illustration below:

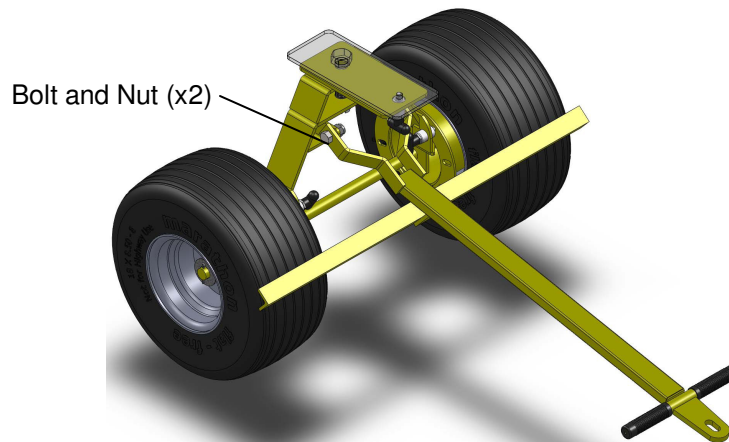

AES RAPTOR TRIREX™ INSTRUCTION MANUAL

2.0 APPLICATIONS

- 2.1 The Raptor TriRex is to be used as an anchorage in a complete mobile fall protection system. The Raptor TriRex may be used where worker mobility and fall protection are required. See WWW.OSHA.GOV for all regulations and standards.
- 2.2 When set up properly the Raptor TriRex allows for three workers to be tied off for fall arrest (using the specially designed fall arrest tie-off rings) and an additional two workers tied-off for fall restraint using the fall restraint tie-off rings. See the following definitions:

DEFINITIONS:

- A. **Fall Restraint System** – A fall restraint system (FRS) *prevents* the user from falling. The system is comprised of a body harness along with an anchorage, connectors and other necessary equipment. The components typically include a lanyard and also may include a lifeline and other devices. The Raptor TriRex can be used as an anchorage in a fall restraint system for up to two workers.
- B. **Personal Fall Arrest System** – A personal fall arrest system (PFAS) *arrests* a fall *after* a fall has begun. The system is comprised of an anchorage, connectors, and a body harness and may include a deceleration lifeline, or suitable combinations. Note that a PFAS does NOT prevent a fall from occurring. The Raptor TriRex can be used as an anchorage in a PFAS for up to three workers. A Personal Fall Arrest System must meet the following OSHA requirements:
 - Limit maximum arresting force on an employee to 1,800 pounds when used with a body harness;
 - Be rigged so that an employee can neither free-fall more than 6 feet (1.8 meters) nor contact any lower level;
 - Bring an employee to a complete stop and limit maximum deceleration distance an employee travels to 3.5 feet (1.07 meters); and
 - Have sufficient strength to withstand twice the potential impact energy of an employee free-falling a distance of 6 feet (1.8 meters) or the free-fall distance permitted by the system, whichever is less.
- C. **Anchorage** — An anchorage is a secure point of attachment for lifelines, lanyards, or deceleration devices. The Raptor TriRex is an anchorage.

3.0 USE AND LIMITATIONS

3.1 USE ON LOW SLOPE SURFACES ONLY

3.2 RECOMMENDED SURFACES INCLUDE:

- | | |
|---|---|
| 1. Built-up Roofing (BUR) Membrane | 11. Gypsum Deck |
| 2. Modified PVC Membranes | 12. Polyisocyanurate (ISO) |
| 3. Thermoplastic Polyolefin (TPO) Membranes | 13. Expanded Polystyrene (EPS) |
| 4. EPDM Roofing Membranes | 14. 4,000 and 6,000 psi Concrete* (See below) |
| 5. Ballasted EPDM Membrane | 15. Flat Surfaces to slopes up to 1:12. |
| 6. Modified Bitumen Membranes | |
| 7. Metal Deck (20 ga. And 22 ga. ONLY) | |
| 8. Dens Deck | |
| 9. Hardboard | |
| 10. Plywood | |

*For Concrete surfaces, see Section 12.0 for concrete use limitations.

3.3 DO NOT USE THE RAPTOR TRIREX SYSTEM ON THE FOLLOWING SURFACES:

- 1. Tectum Deck
- 2. Metal Deck less than 22 ga. Or over 20 ga. (Structural Deck)
- 3. Loose laid material not part of a complete finished system.
- 4. Ice
- 5. Snow

**** BEFORE A RAPTOR IS HOISTED TO ANY ROOF SURFACE ****
THE CONTRACTOR MUST VERIFY THAT THE DECK ASSEMBLY CAN ACCOMMODATE THE LIVE LOAD REQUIREMENTS OF THE RAPTOR.

AES RAPTOR TRIREX™ INSTRUCTION MANUAL

3.4 CAPACITY: The Raptor TriRex Mobile Fall Protection System is designed for a maximum of three persons for fall arrest and two for fall restraint with a combined weight (clothing, tools) of no more than 310 lbs. per person. No more than five persons may be connected to the Raptor TriRex at any time.

IMPORTANT: DO NOT begin work for which fall protection is required until the TriRex unit and corresponding FRS or PFAS have been completely installed. Do NOT disable any part of the FRS or PFAS, including the TriRex unit, or reposition the TriRex unit, until work for which fall protection is required has ceased.

3.5 POSITIONING THE UNIT: First, verify that the surface that the Raptor TriRex will be installed onto is capable of supporting the product and personnel using it. A complete assessment of the entire surrounding areas should be made to determine if the working surfaces have the strength and structural integrity to support users safely.

A. Position the Raptor TriRex such that the attachment plate is between 12 to 15 feet from the leading edge, and in line with the middle of the area to be worked. Refer to the Illustration below:

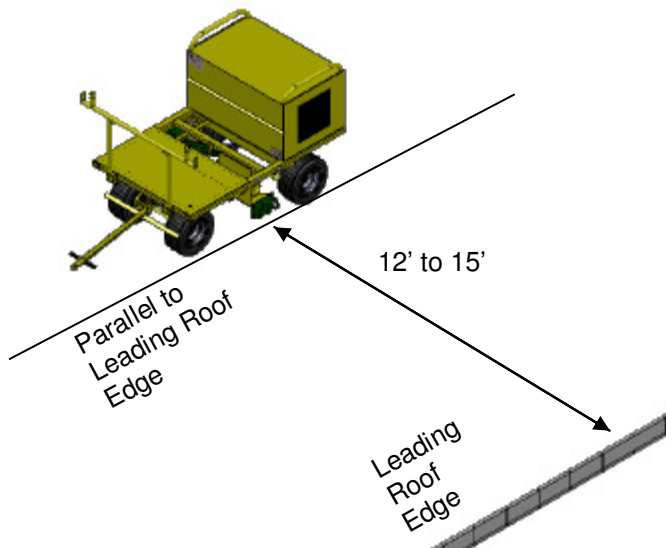

B. Make sure the Attachment Tie-off Rings are pointing toward the leading edge and the cart is set to travel parallel to the leading edge. Make sure the tire brake rests firmly against the front tires. Then set the handle by aligning the front axle with the unit and then locking the axle in place by pushing the spring-loaded pin into the corresponding slot. Next, lock the front wheels in place by pushing the spring-loaded pins into the nearest wheel slots. Refer to the following illustration:

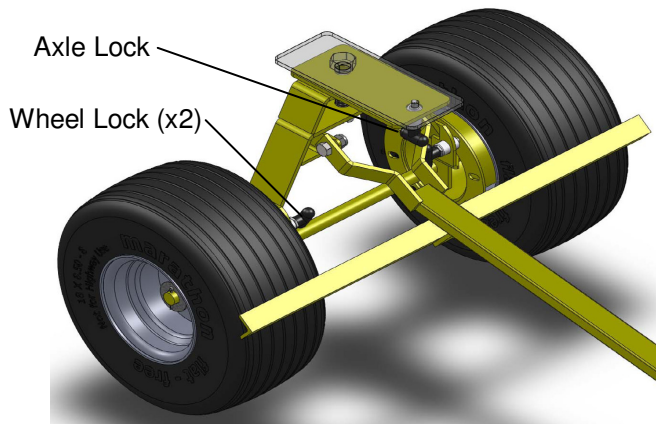

AES RAPTOR TriREX™ INSTRUCTION MANUAL

E
N
G
L
I
S
H

PLAN VIEW

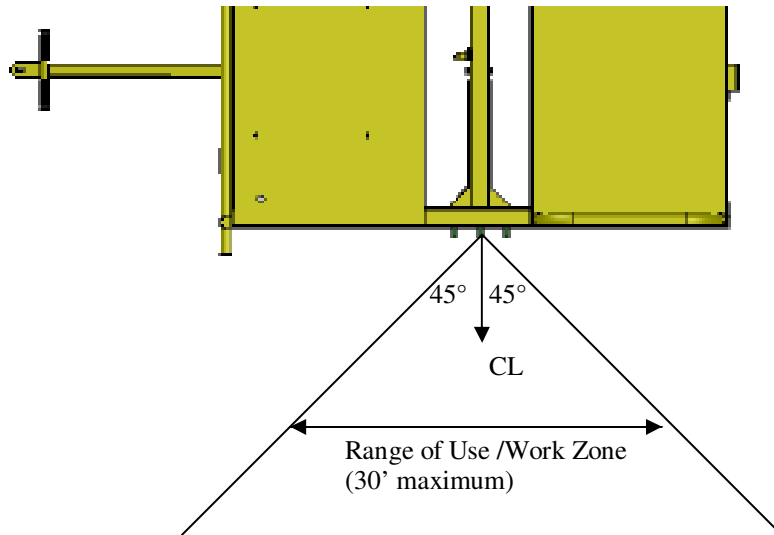

PLAN VIEW

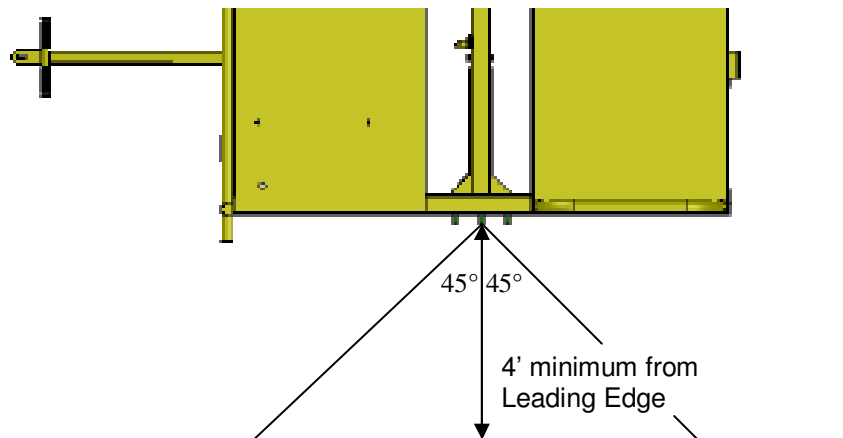

4.0 MAKING CONNECTIONS:

- 4.1 Only connect the Safety Tie-Off Plate to the Safety Engagement Arm using the provided Safety Cable. If the Safety Cable is broken, remove from service immediately and contact AES Raptor, LLC at 1-888-990-2990. If the Safety Cable is lost or stolen, contact AES Raptor, LLC at 1-888-990-2990.
- 4.2 DO NOT hook lifeline to any point except a Fall Arrest or Fall Restraint Tie-off Ring.
- 4.3 When making connections, only use self-locking snap hooks and self-locking carabiners with this equipment. Only use connectors that are suitable to each application. Ensure all connections are compatible in size, shape and strength. Do not use equipment that is not compatible. Ensure that all connectors are fully closed and locked.

5.0 FALL RESTRAINT TIE-OFF RINGS:

- 5.1 The Fall Restraint Tie-Off Rings are installed on either side of the Safety Engagement Arm.
- 5.2 The Fall Restraint Tie-Off Rings DO NOT arrest falls . The user must verify that the FRS, including lanyards, harnesses, etc., DO NOT allow the user to fall from any edge.

6.0 BEFORE EACH USE:

- 6.1 OSHA 1926.502 requires that before operating the system there must be an inspection for damaged equipment.

INSPECTION STEPS

- STEP 1: Check for loose, bent or damaged parts, including talon and claw tips.
- STEP 2: Check welded connections for distortion, cracks, or other damage.
- STEP 3: Check Tie-off Rings for distortion or damage.
- STEP 4: Check cables for rusting and/or wear before each use – DO NOT use if cable and cable connections have been damaged.
- STEP 5: All labels must be present and fully legible. (Copies of all labels are attached at the back of this section for accurate inspection.)
- STEP 6: Check for corrosion on entire unit.
- STEP 7: Check Safety Cable Ring Attachment plate for freedom of movement.
- STEP 8: Check Engagement Arm for freedom of movement.
- STEP 9: Check that the Engagement Arm Locking Mechanism is in the proper spring-loaded position.

Contact AES Raptor, LLC at 1-888-990-2990 for replacement parts.

6.2 IMPORTANT: IF THIS UNIT HAS BEEN USED IN A FALL ARREST:

The bronze bushings located at the pin connection where the Engagement Arm is attached to the frame MUST be replaced regardless of the magnitude of the previous fall. Contact AES Raptor, LLC at 1-888-990-2990 for replacement parts.

IMPORTANT: BEFORE USING THIS UNIT, A RESCUE PROCEDURE (PLAN) MUST BE ADOPTED AND LEARNED. A FALL EVENT IS NOT THE TIME TO DEVELOP SUCH PLANS.

- 6.3 OSHA 1926.502(d) requires employers to provide prompt rescue of employees in the event of a fall or employers shall assure that employees are able to rescue themselves. It is IMPOSSIBLE to guarantee that an employee can rescue himself because he may be unconscious or injured as a cause or result of the fall. Therefore, a rescue procedure involving rescuers necessarily must be adopted. See Section 10.0 in this manual for procedure for handling the TriRex during a rescue. See Section 11.0 for greatly simplifying your rescue procedure, and increasing your chance of effecting a rescue, with the Raptor Rescue Retrieval System (highly recommended) and Raptor Alert (highly recommended).

DO NOT OPERATE DAMAGED EQUIPMENT. DO NOT OPERATE EQUIPMENT THAT HAS BEEN MODIFIED.
(Please use the Inspection and Maintenance Log on page 12.)

6.4 MAINTENANCE, CARE, and STORAGE:

- A. Inspect all AES Raptor equipment and parts before and after each use.
- B. Keep wheels free from roofing build up or debris. Asphalt or adhesive build up on the tires can cause the wheel brake to function improperly.
- C. Regularly inspect all bolts, pins, springs, etc. Damaged or missing pins can severely hinder the safety factor of the Raptor.

AES RAPTOR TriRex™ INSTRUCTION MANUAL

- D. Store TriRex unit in a place protected from weather and where only authorized employees have access.
- E. Maintain paint finish to prevent corrosion.

7.0 GENERAL SAFETY

- 7.1 USE COMMON SENSE! Most accidents can be avoided by using common sense and concentrating on the job to be done.
- 7.2 The AES Raptor TriRex should not be used by persons whose ability or alertness is impaired by fatigue, intoxicating beverages, illegal or prescription drugs, or any other physical cause that exposes the user or others to injury.
- 7.3 Always wear proper safety attire.
- 7.4 Keep hands and feet clear of moving parts, Engagement Arm, etc. DO NOT stick hands or fingers in the equipment when operating.
- 7.5 Do not operate the equipment near electrical power lines.
- 7.6 Do not allow passengers to ride on safety cart.
- 7.7 Allow handle to drop and set brake when not in use.
- 7.8 Ensure that the safety arm works properly. Make sure that all areas directly underneath, and in front of the cart, are clear and free of debris.
- 7.9 Do not use on icy roofs.
- 7.10 Only use the unit on a surface or roof composition for which it has been tested.
- 7.11 Do not set unit atop unfastened materials. Materials may slide if not mechanically attached to the roof.
- 7.12 Depending on the presence of added weight on the unit (including materials, tools, generator) and the present circumstances, additional workers may be required to safely move the unit. Always use caution and common sense when moving the unit.

8.0 GENERATOR/AIR COMPRESSOR SAFETY:

- 8.1 When applicable: Always refer to Generator/Air Compressor User Manuals for use and safety directions.
- 8.2 Never let extension cords or the plug connection lay in water. Locate the equipment such that electrical components or equipment cannot fall into water.
- 8.3 Never use cords with frayed, cut or brittle insulation. Check the cord on the motor for nicks in the insulation and for sound connections to the ground fault interrupter plug and motor.
- 8.4 Operate in well ventilated areas only.
- 8.5 Do not breathe exhaust fumes when working in the area of the engine. (Exhaust gasses are odorless and can be fatal.)
- 8.6 Keep the exhaust system components tight and in good working condition.
- 8.7 Exhaust system parts get very hot and stay hot for some time after shutting the engine off – Do Not Touch.

AES RAPTOR TRIREX™ INSTRUCTION MANUAL

- 8.8 Never add fuel to the tank while the engine is running. Stop engine and allow it to cool. Avoid spilling fuel.
- 8.9 Do not refuel near open flame; wipe up spilled fuel.
- 8.10 Never remove factory-installed equipment from the cart. If any equipment is removed then the cart is deemed useless for fall protection.

9.0 HOISTING: ***WARNING***

- 9.1 Loads may slip or fall , if the TriRex Unit is not hoisted properly, resulting in injury or death.
- 9.2 Do not use with damaged slings or chain. For inspection criteria see ASME B30.9.
- 9.3 Utilize appropriate Rigging Gear suitable for overhead lifting.
- 9.4 Utilize Rigging Gear within the industry standards and the manufacturer’s recommendations.
- 9.5 Conduct regular inspection and maintenance of the Rigging Gear.
- 9.6 **DO NOT** hook lifeline to designated Hoisting Guide-Rings.
- 9.7 **Secure auxillary equipment and material before hoisting the TriRex.**
- 9.8 The Raptor TriRex was designed to be hoisted by a crane with the use of a four-leg wire rope sling or bridle chain sling. The TriRex may also be lifted by a forklift using the designated Fork Pockets. Refer to the following illustration for proper hoisting:

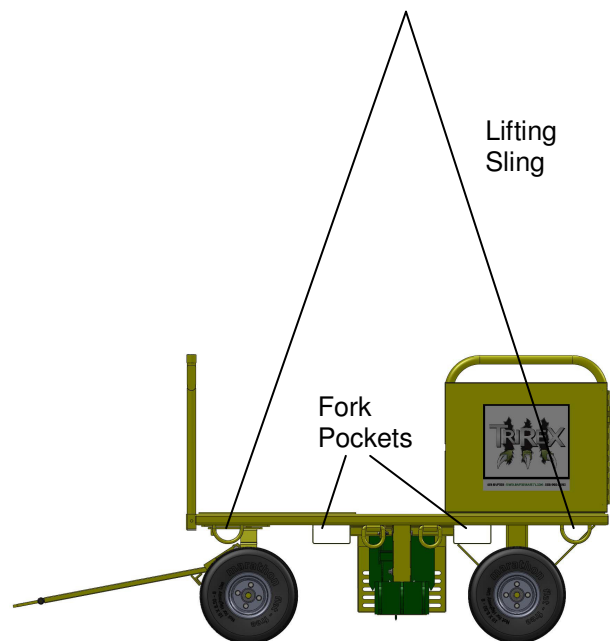

HOISTING DIAGRAM

AES RAPTOR TRIREX™ INSTRUCTION MANUAL

10.0 PROCEDURE FOR HANDLING THE TRIREX IN THE EVENT OF A FALL

- 10.1 Before rescuing a fallen employee, assess the TriRex Unit to be certain it has stabilized after activation. It is highly recommended that any rescuer be tied off in a FRS before attempting to aid in a rescue. The number of rescuers allowed to tie off to the TriRex PFAS attachment rings is 3 (three) minus the number of fallen workers. Up to 2 (two) additional rescuers may tie off to the TriRex to the fall restraint tie-off rings (for FRS).
- 10.2 If the TriRex unit comes with a Raptor Rescue Retrieval System (highly recommended, see Section 11.0 below), simply extend the cable to the fallen worker, verify that the worker has secured himself to the cable carabiner, and crank the winch until the worker can climb onto the roof, can be pulled onto the roof by rescuers, or can be lowered to the level below.
- 10.3 Complete the rescue procedure before attempting to “de-activate” the TriRex Unit. When the TriRex has been activated, the Engagement Arm will likely be severely wedged into the roof surface. Disengage the Locking Mechanism by pulling the locking mechanism handle. Use a wooden or metal beam to apply leverage to the Engagement Arm to disengage the claw and/or talon from the roof surface. Use caution when disengaging the moving parts. Keep hands and feet free of all pinch points.
- 10.4 Do not reuse any TriRex Unit until appropriate recertification and inspection has been performed.

11.0 Importance of the Raptor Rescue Retrieval System and Raptor Alert

- 11.1 OSHA 1926.502(d) requires employers to provide prompt rescue of employees in the event of a fall or employers shall assure that employees are able to rescue themselves. To that end, most general contractors require site-specific rescue plans. This is extremely time-consuming and leaves the possibility of oversight or unaccounted-for site changes. The alternative is installing and using the Raptor Rescue Retrieval System. It can be used wherever the TriRex is used, and is completely intuitive and easy to use, giving rescuers a simple means to retrieve the fallen worker, in every situation.
- 11.2 A well-thought-out rescue plan is USELESS if no one is aware of a fall. Jobsites are noisy, and workers are focused on the task at hand. Therefore a co-worker is likely to fall without nearby rescuers taking any action. The Raptor Alert greatly increases the chance of a rescue by emitting a 130 decibel siren and amber strobe-light.
- 11.3 If your TriRex is not equipped with the Raptor Rescue Retrieval System or Raptor Alert, contact AES Raptor, LLC at 1-888-990-2990 or your local dealer to order the Raptor Rescue Retrieval System and Raptor Alert and tremendously increase the effectiveness of the TriRex and likelihood of a successful rescue.

12.0 Concrete Use Limitations

- 12.1 The AES Raptor TriRex is rated for 4,000 and 6,000 psi concrete fall arrest of a maximum of 2 (two) and NOT 3 (three). Do NOT under any circumstances tie off more than 2 (two) workers in a PFAS configuration (i.e. to the fall arrest attachment rings) to an AES Raptor TriRex fall arrest unit when using the TriRex on Concrete.
- 12.2 If using the TriRex Unit on any type of Concrete surface, install the Attachment Restrictor on one of the TriRex Attachment Rings, to prevent a third person from tying-off to the Unit.
- 12.3 Make sure the concrete surface is not wet (i.e. precipitation, condensation, water run-off), is not oily or covered in any substance, and is free of debris including loose dust.
- 12.4 If there is any question or uncertainty about a particular substrate or configuration, contact AES Raptor, LLC at 1-888-990-2990.
- 12.5 To have a specific substrate/configuration tested for your specific application, contact AES Raptor, LLC at 1-888-990-2990.

AES RAPTOR TriREX™ INSTRUCTION MANUAL

WARNING LABELS

Upon each inspection please use this page to verify that all six Warning Labels are present and fully legible.



(One is to be located by each Hoisting Guide-Ring for a total of four)

! WARNING:	! ADVERTENCIA:	! AVERTISSEMENT
<p>This product is not designed for storing or transporting flammables, explosives, hazardous wastes or hazardous materials such as containers of solvents, gun powder, dynamite, gasoline, propane or acetylene tanks, etc.</p> <p>Any modification to or unintended use of this product could create a danger of an explosion or other hazardous condition that can result in death, serious injury or property damage.</p>	<p>Este producto no está diseñado para almacenar ni transportar materiales inflamables, explosivos, desperdicios o materiales peligrosos como contenedores de solventes, pólvora, dinamita, gasolina, tanques de propano o de acetileno, etc.</p> <p>Cualquier modificación que se haga a este producto o cualquier uso que se haga del mismo, que no sea el uso para el que se diseñó, podría crear un peligro de explosión u otra condición peligrosa que puede tener como resultado la muerte, las lesiones graves o los daños a la propiedad.</p>	<p>Ce produit n'est pas conçu pour stocker ou transporter des produits inflammables, des explosives, des déchets dangereux ou des matières dangereuses telles que des bidons de solvant, de la poudre explosive, de la dynamite, de l'essence, des réservoirs de propane ou d'acétylène, etc.</p> <p>Toute modification ou utilisation non prévue de ce produit peut créer un danger d'explosion et d'autres conditions dangereuses, pouvant entraîner la mort, des blessures graves ou des dommages matériels.</p>

(Located inside the job box)

! WARNING: TO PREVENT BODILY INJURY	OWNER
<p>OWNERS AND OPERATORS OF THIS EQUIPMENT SHOULD, PRIOR TO USING:</p> <p>Read the instruction manual. Read all warning labels. Know and comply with all OSHA, state and local regulations concerning roofing.</p>	<p>All employees should be instructed in the proper use of this equipment prior to use. If the employee cannot read or understand English, please provide a translator. This equipment should not be sold to, traded, or given to any other company or individual without instructing them in its proper use and without providing them with all instructions and warning labels.</p>
! ADVERTENCIA: PARA PREVENIR LAS LESIONES CORPORALES	DUENO
<p>LOS DUEÑOS Y LOS OPERADORES DE ESTE EQUIPO DEBEN, ANTES DE UTILIZARLO:</p> <p>Leer el manual de instrucciones. Leer todos los rótulos de advertencia. Saber y cumplir todos los reglamentos de OSHA, así como los reglamentos locales y estatales relacionados con el techado</p>	<p>Todos los empleados deben recibir instrucción sobre el uso apropiado de este equipo antes de utilizarlo. Si el empleado no puede leer o entender inglés, por favor, proporcione un traductor. Este equipo no se debe vender, comerciar ni entregar a ninguna otra compañía o persona sin instruirle en el uso apropiado o sin proporcionarle todas las instrucciones y los rótulos de advertencia.</p>
! AVERTISSEMENT: POUR EVITER LES BLESSURES	PROPRIÉTAIRE
<p>LES PROPRIÉTAIRES ET OPÉRATEURS DE CET ÉQUIPEMENT DOIVENT EFFECTUER LES ACTIONS SUIVANTES AVANT D'UTILISER LE PRODUIT:</p> <p>Lire le manuel d'instructions. Lire toutes les étiquettes d'avertissement. Connaître et respecter toutes les normes OSHA et les règlements locaux et provinciaux concernant les travaux de toiture</p>	<p>Tous les employés doivent être formés à l'utilisation appropriée de cet équipement avant de l'utiliser. Si l'employé ne peut pas lire ou comprendre l'français, un traducteur doit être fourni. Cet équipement ne doit pas être vendu, échangé, ni donné à une autre société ou à une autre personne sans les avoir préalablement formées à son utilisation correcte et sans leur avoir procuré toutes les instructions et étiquettes d'avertissement.</p>

(Located on the back of the job box)

AES RAPTOR TriREX™ INSTRUCTION MANUAL

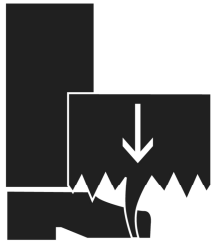
	CAUTION	PRECAUCIÓN	PRUDENCE
	PINCH POINT KEEP FEET CLEAR	PUNTO DE AGARRE MANTENGA LOS PIES A UNA DISTANCIA SEGURA	POINT DE PINCEMENT ÉLOIGNER LES PIEDS

(Located on the guard)

	CAUTION	PRECAUCIÓN	PRUDENCE
	PINCH POINT	PUNTO DE AGARRE	POINT DE PINCEMENT

(Located below the Job Box handle)

WORK		ZONE
ZONA DE TRABAJO ZONE DE TRAVAUX		
		

(Located above the Tie-Off Ring Attachment plate)

AES RAPTOR TRIREX™ INSTRUCTION MANUAL

E
N
G
L
I
S
H



Raptor Inspection and Maintenance Log

PLEASE COPY THIS LOG, FILL IT OUT BEFORE EACH USE, AND KEEP IT IN YOUR RECORDS.

RAPTOR SERIAL #:			
RAPTOR MODEL #:			
DATE PURCHASED:			
INSPECTION DATE:			
Inspection Item Noted:	Corrective Action Needed?		Maintenance Performed:
	Yes	No	
Overall Cart Parts			
<i>Approved By:</i>			
Welded Connection			
<i>Approved By:</i>			
Safety Lifeline Tie-off Rings and Hoisting D-Rings			
<i>Approved By:</i>			
Cables			
<i>Approved By:</i>			
Labels			
<i>Approved By:</i>			
Overall Cart Corrosion			
<i>Approved By:</i>			

AES RAPTOR TriREX™ INSTRUCTION MANUAL



Copyright © 2010 by AES Raptor, LLC
1349 Taney, North Kansas City MISSOURI 64116
www.raptorsafety.com

PRINTED IN THE UNITED STATES OF AMERICA