

Roof Anchor Point

Instruction Manual

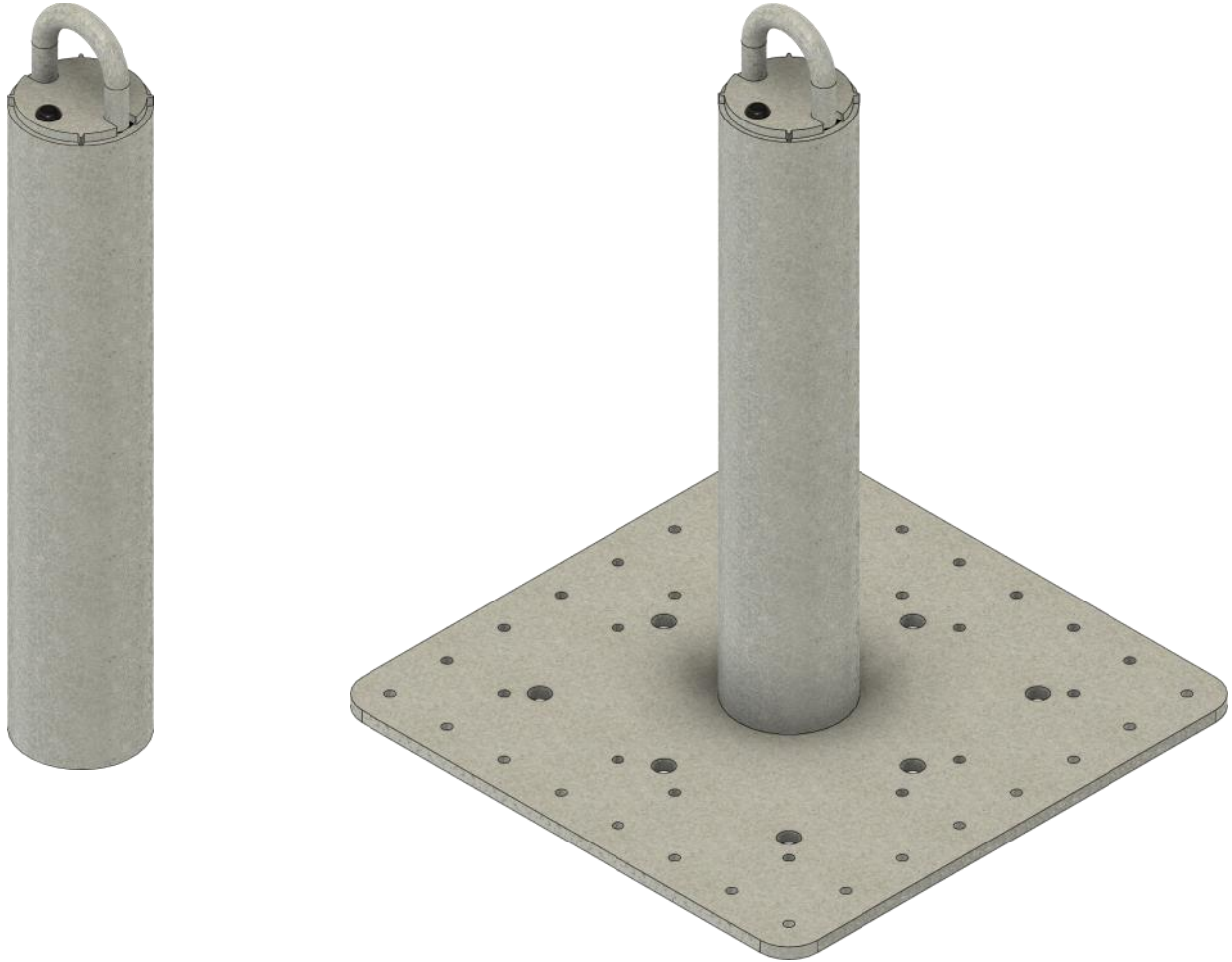

WARNING

Do not alter or misuse this equipment. Serious injury or death may result if this product is used for purposes other than designed. The manufacturer provides the following instructions for the use and care of this equipment. It is the responsibility of the purchaser to understand and convey explicit instruction to each user. The AES Manufacturing/Leading Edge Safety Roof Anchor Point complies with the requirements of the Federal Occupational Safety and Health Administration (OSHA) when set up and used according to the manufacturers' instructions.

LIT ID: RAP-IM-22.1129

**WE TAKE THE FIRST STEP
SO YOU DON'T TAKE YOUR LAST**



ROOF ANCHOR POINT INSTRUCTION MANUAL

TABLE OF CONTENTS

INTRODUCTION

Standards and Requirements	3
Applications	3
Definitions	4
Material Specifications	5
Product Part Numbers	5
Product Components	6

ROOF ANCHOR POINT ASSEMBLY DETAILS

Concrete Screw Anchors - 12" & 18" Risers	7
Concrete Screw Anchors - 24" Risers	8
Concrete Wedge Anchors - 12" & 18" Risers	9
Concrete Wedge Anchors - 24" Risers	10
Concrete Thru-Bolt - 12" & 18" Risers	11
Concrete Thru-Bolt - 24" Risers	12
Concrete Chemical Anchors - 12" & 18" Risers	13
I-Beam Thru-Bolt - 12", 18" & 24" Risers	14
I-Beam Welded - 12", 18" & 24" Risers	15
Metal Deck - 22ga Min - 12" Risers	16
Metal Deck - Less Than 22ga - 12" Risers	17
Metal Deck - Insulation & OSB - 12" & 18" Risers	18
Metal Deck - All Metal Decks - 12" & 18" Risers	19
Plywood Deck - 3/4" Min - 12" & 18" Risers	20
Plywood or OSB Deck - 12" & 18" Risers	21
Plywood Deck - Sandwich Deck Assembly - 12" & 18" Risers	22

ROOF ANCHOR POINT - PLATE DIMENSIONS

12", 18" & 24" Risers	23
Backup Plate	24

RECOMMENDED FASTENERS

Concrete Application	25
I-Beam Application	26
Metal Decks	27
Wood Decks	28

USE & LIMITATIONS

Use & Limitations	29
Making Connections	32
Inspections, Use, & Care	32
In the Event of a Fall	33

ROOF ANCHOR POINT INSTRUCTION MANUAL

E
N
G
L
I
S
H

LEADING EDGE SAFETY, LLC **Roof Anchor Point Instruction Manual**

Published by Leading Edge Safety, LLC
North Kansas City, MO

Leading Edge Safety, LLC
1345 Taney St
North Kansas City, MO 64116
www.LeadingEdgeSafety.net

Copyright © 2022 by Leading Edge Safety, LLC
PRINTED IN THE UNITED STATES OF AMERICA

ROOF ANCHOR POINT INSTRUCTION MANUAL

1.0 Standards and Requirements

- 1.1** The Roof Anchor Point, manufactured by Leading Edge Safety LLC, is an anchorage designed for a single user in either fall arrest or fall restraint. Do not connect more than one person to a Roof Anchor Point. Roof Anchor Points are capable of supporting at least 5,000lbs (22.2kN) or a Maximum Arresting Force (MAF) of 1,800lbs (8.0kN) when used and installed according to product installation instructions and designed by qualified person.
- 1.2** The Roof Anchorage Point anchorage shall only be used as part of a complete active fall protection system. Therefore, the following criteria must be met to satisfy applicable OSHA 1926 Subpart M, OSHA 1910, ANSI Z359.18-2017, and ANSI A10.32-2012 Standards:
- 1.2a** Use of full body harness(s) in compliance with Z359.1-2007 "Safety Requirements for Personal Fall Arrest Systems, subsystems, and Components"
 - 1.2b** Use of Lanyard(s) In compliance with Z359.13-2009 "Personal Energy Absorbers and Energy Absorbing Lanyards"
 - 1.2c** Use of Connection(s) In compliance with Z359.12-2009 "Connecting Components for Personal Fall Arrest Systems"
 - 1.2d** Use of Manufacturer's Recommendations; the Roof Anchor Point shall not be installed/positioned/utilized in a manner that violates the literature, instructions, technical bulletins or any other documentation produced by Leading Edge Safety LLC.
 - 1.2e** Calculations by an authorized user (qualified person) to verify that the substrate, edge distance, free fall distance, and the number of workers attached to anchorage satisfies those requirements of ANSI Z359.6.
 - 1.2f** The use of component(s) used in combination with the anchorage that are not covered by ANSI/ASSE Z359 will not result in an acceptable Active Fall Protection System.
- 1.3** The Roof Anchor Point has been tested in compliance with ANSI Z359.7 requirements. Testing is applicable to the anchorage and does not extend to the connection of the substrate the anchorage is secured to.

2.0 Applications

- 2.1** The Roof Anchor Point is designed to be used as an anchorage as part of a complete personal fall protection system (PFAS). The Roof Anchor Point may be used where worker mobility and fall protection are required. See WWW.OSHA.GOV for all current regulations and standards.
- 2.2** The Roof Anchor Point allows for one worker to be tied-off for fall arrest or fall restraint to the *Connection Point*. See the following definitions (Section 3.0).
- 2.3** Roof Anchor Points may be used as part of a HLL system for up to two workers when the complete system is designed by a qualified person and installed by a competent per the manufacture's instructions.
- 2.4** Roof Anchor Points may used on structures and substrates capable of withstanding applicable loads applied in all permissible for the specific application.
- 2.5** Roof Anchor Points may be used for fall restraint on substrates with a 4/12 slope or less.

ROOF ANCHOR POINT INSTRUCTION MANUAL

3.0 Definitions

- 3.1 Anchorage** — An anchorage is a secure point of attachment for lifelines, lanyards, or deceleration devices. The Roof Anchor Point can be used as an anchorage for one worker.
- 3.2 Connector** — a device which is used to couple (connect) parts of the personal fall arrest system and positioning device systems together. It may be an independent component of the system, such as a carabiner, or it may be an integral component of part of the system (such as a buckle or D-ring sewn into a body belt or body harness, or a snap-hook spliced or sewn to a lanyard or self-retracting lanyard).
- 3.3 Fall Restraint System**— A fall restraint system (FRS) *prevents* the user from falling. The system is comprised of a body harness along with an anchorage, connectors and other necessary equipment. The components typically include a lanyard and also may include a lifeline and other devices. The Roof Anchor Point can be used as an anchorage in a fall restraint system for one worker.
- 3.4 Lanyard**— A flexible line of rope, wire rope, or strap which generally has a connector at each end for connecting the body belt or body harness to a deceleration device, lifeline, or anchorage.
- 3.5 Lifeline** — A component consisting of a flexible line for connection to an anchorage at one end to hang vertically (vertical lifeline), or for connection to anchorages at both ends to stretch horizontally (horizontal lifeline), and which serves as a means for connecting other components of a personal fall arrest system to the anchorage.
- 3.6 Personal Fall Arrest System** – A personal fall arrest system (PFAS) arrests a fall *after* a fall has begun. The system is comprised of an anchorage, connectors, and a body harness and may include a deceleration lifeline, or suitable combinations. Note that a PFAS does NOT prevent a fall from occurring. The Roof Anchor Point can be used as an anchorage in a PFAS for one worker. A Personal Fall Arrest System must meet the following OSHA requirements:
- Limit maximum arresting force on an employee to 1,800 pounds when used with a body harness;
 - Be rigged so that an employee can neither free-fall more than 6 feet (1.8 meters) nor contact any lower level;
 - Bring an employee to a complete stop and limit maximum deceleration distance an employee travels to 3.5 feet (1.07 meters); and
 - Have sufficient strength to withstand twice the potential impact energy of an employee free-falling a distance of 6 feet (1.8 meters) or the free-fall distance permitted by the system, whichever is less.
- 3.7 Rope Grab** — A deceleration device which travels on a lifeline and automatically, by friction, engages the lifeline and locks so as to arrest the fall of an employee. A rope grab usually employs the principle of inertial locking, cam/level locking, or both.
- 3.8 Self-Retracting Lifeline/Lanyard** — A deceleration device containing a drum-wound line which can be slowly extracted from, or retracted onto, the drum under slight tension during normal employee movement, and which, after onset of a fall, automatically locks the drum and arrests the fall.
- 3.9 Snaphook** — A connector comprised of a hook-shaped member with a normally closed keeper, or similar arrangement, which may be opened to permit the hook to receive an object and, when released, automatically closes to retain the object.

ROOF ANCHOR POINT INSTRUCTION MANUAL

E
N
G
L
I
S
H

4.0 Material Specifications

Riser Height	Post Material	Post O.D.	Base Plate Thickness	Base Plate Dim	Securement Type	Fastener Holes	Weight (lbs)	Part #
12"	Sched 40	3.5"	3/8"	16" x 16"	Screw/Bolt On	40 Wood/Metal/8 Concrete		RAP-12-1616-23
	Sched 40	3.5"	N/A	N/A	Weld On	5/16" Field Weld		RAP-012-35-23
18"	Sched 40	3.5	3/8"	16" x 16"	Screw/Bolt On	40 Wood/Metal/8 Concrete		RAP-18-1616-23
	Sched 40	3.5	N/A	N/A	Weld On	5/16" Field Weld		RAP-018-35-23
24"	Sched 40	4.5	5/8"	16" x 16"	Screw/Bolt On	8 Concrete		RAP-24-1616-23
	Sched 40	4.5	N/A	N/A	Weld On	5/16" Field Weld		RAP-024-45-23

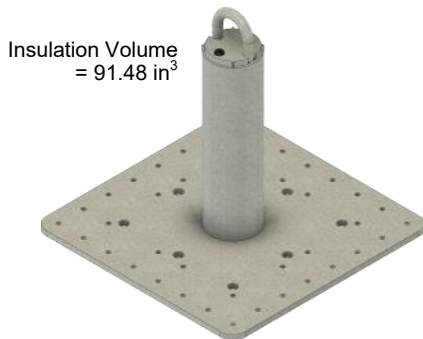

RAP-12-1616-23

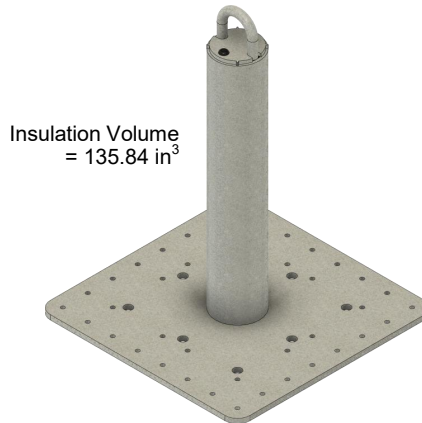

RAP-18-1616-23



RAP-24-1616-23



RAP-BP-1111-0.1875



RAP-012-35-23



RAP-018-35-23

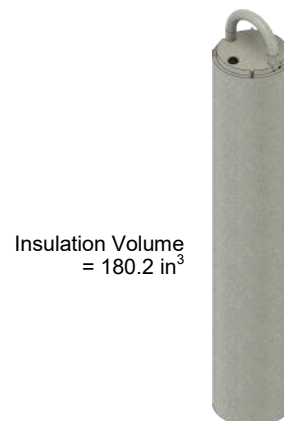

RAP-024-45-23

ROOF ANCHOR POINT INSTRUCTION MANUAL

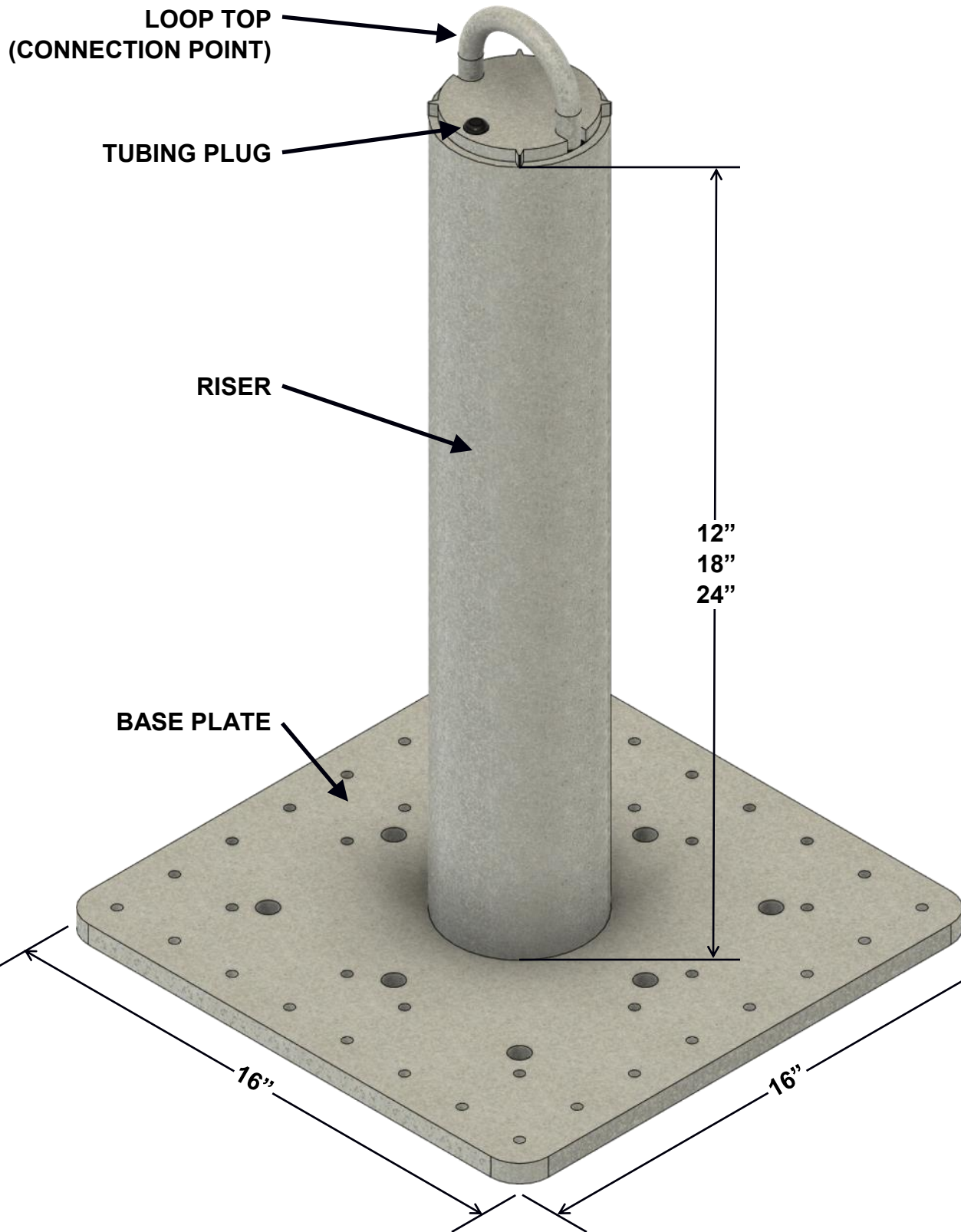

ROOF ANCHOR POINT INSTRUCTION MANUAL

E
N
G
L
I
S
H

Roof Anchor Point - 12" & 18" Riser Concrete Screw Anchor

FASTENERS REFERENCE
PAGE 25

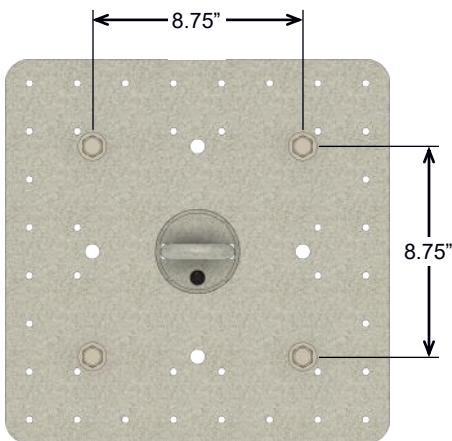
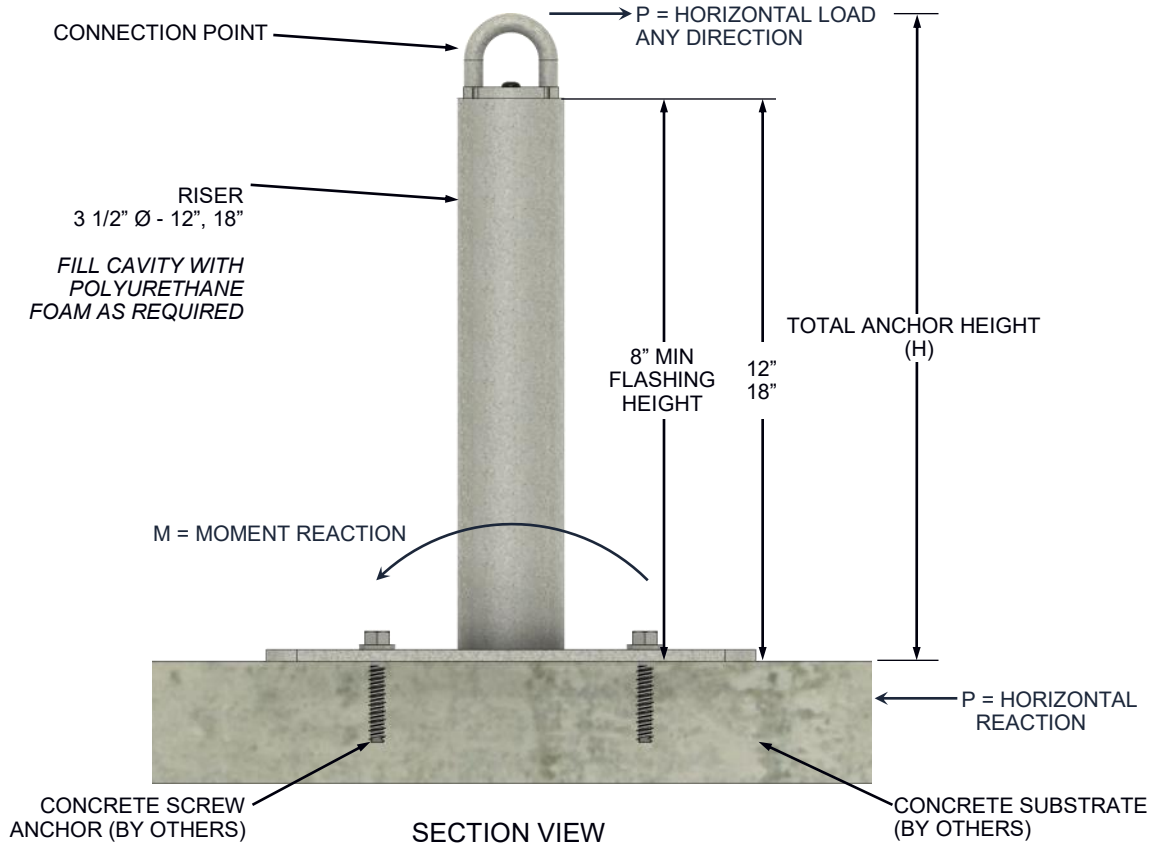

Materials

Riser:	12", 18"	3" Schedule 40 pipe ASTM A53
Base Plate:	12", 18"	0.375" x 16" x 16" ASTM A36
Riser Cap:	12", 18"	0.375" x 3.2"Ø ASTM A36
Loop Top:	All	0.625"Ø ASTM A36
Finish:		Hot-Dipped Galvanized ASTM A123

Structural Connections

- Design shall be approved by a qualified engineer to local standards and codes.
- Installation of field bolts shall be inspected in accordance with AISC guidelines.
- All welding shall conform to AWS code.
- All bolts shall be installed to a snug-fit condition, properly aligned with holes.
- All welds on drawing shall be shop weld.
- Welded connection shall have a minimum 5/16" fillet weld.
- Weld size on drawings is considered effective weld size and shall increase as required by skews or gaps between components in accordance with AWS.
- Reinforcing of structure to completed by other as required.

Design Loads

*All loads are factored

RISER	H (inches)	P (lbs)	M (in-lbs)
12"	14.8	5000	74000
18"	20.8	5000	104000

ROOF ANCHOR POINT INSTRUCTION MANUAL

ENGLISH

Roof Anchor Point - 24" Riser Concrete Screw Anchor

FASTENERS REFERENCE
PAGE 25

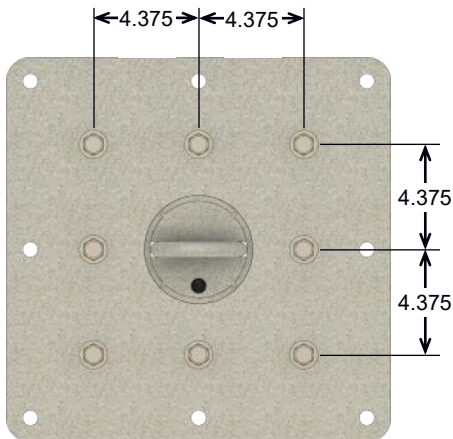
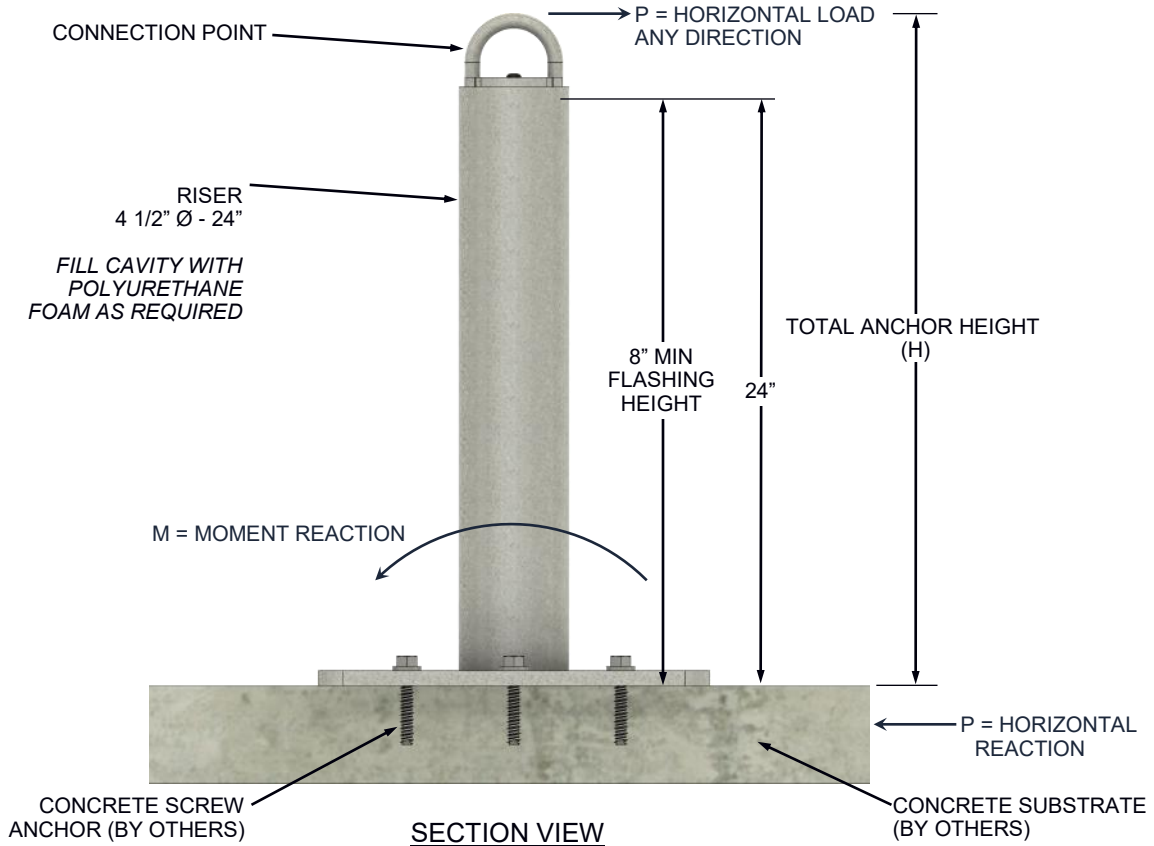

Materials

Riser:	24"	4" Schedule 40 pipe ASTM A53
Base Plate:	24"	0.625" x 16" x 16" ASTM A36
Riser Cap:	24"	0.375" x 4"Ø ASTM A36
Loop Top:	All	0.625"Ø ASTM A36
Finish:		Hot-Dipped Galvanized ASTM A123

Structural Connections

- Design shall be approved by a qualified engineer to local standards and codes.
- Installation of field bolts shall be inspected in accordance with AISC guidelines.
- All welding shall conform to AWS code.
- All bolts shall be installed to a snug-fit condition, properly aligned with holes.
- All welds on drawing shall be shop weld.
- Welded connection shall have a minimum 5/16" fillet weld.
- Weld size on drawings is considered effective weld size and shall increase as required by skews or gaps between components in accordance with AWS.
- Reinforcing of structure to completed by other as required.

Design Loads

*All loads are factored

RISER	H (inches)	P (lbs)	M (in-lbs)
24"	27	5000	135000

ROOF ANCHOR POINT INSTRUCTION MANUAL

ENGLISH

Roof Anchor Point - 12" & 18" Riser Concrete Wedge Anchor

FASTENERS REFERENCE
PAGE 25

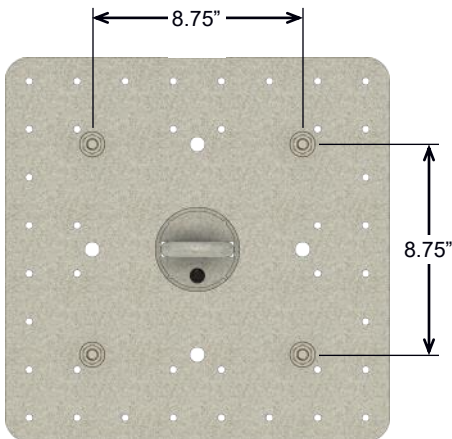
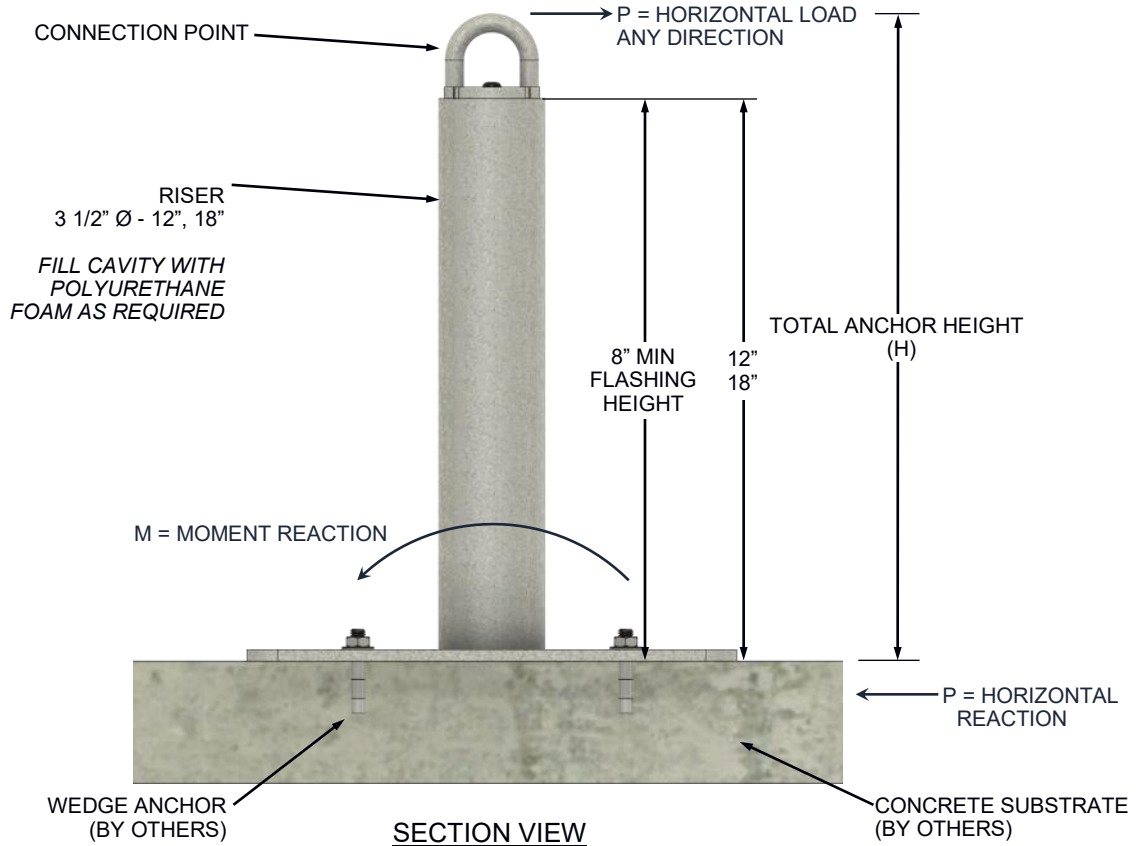

Materials

Riser:	12", 18"	3" Schedule 40 pipe ASTM A53
Base Plate:	12", 18"	0.375" x 16" x 16" ASTM A36
Riser Cap:	12", 18"	0.375" x 3.2"Ø ASTM A36
Loop Top:	All	0.0625"Ø ASTM A36
Finish:		Hot-Dipped Galvanized ASTM A123

Structural Connections

- Design shall be approved by a qualified engineer to local standards and codes.
- Installation of field bolts shall be inspected in accordance with AISC guidelines.
- All welding shall conform to AWS code.
- All bolts shall be installed to a snug-fit condition, properly aligned with holes.
- All welds on drawing shall be shop weld.
- Welded connection shall have a minimum 5/16" fillet weld.
- Weld size on drawings is considered effective weld size and shall increase as required by skews or gaps between components in accordance with AWS.
- Reinforcing of structure to completed by other as required.

Design Loads

*All loads are factored

RISER	H (inches)	P (lbs)	M (in-lbs)
12"	14.8	5000	74000
18"	20.8	5000	104000

ROOF ANCHOR POINT INSTRUCTION MANUAL

E
N
G
L
I
S
H

Roof Anchor Point - 24" Riser Concrete Wedge Anchor

FASTENERS REFERENCE
PAGE 25

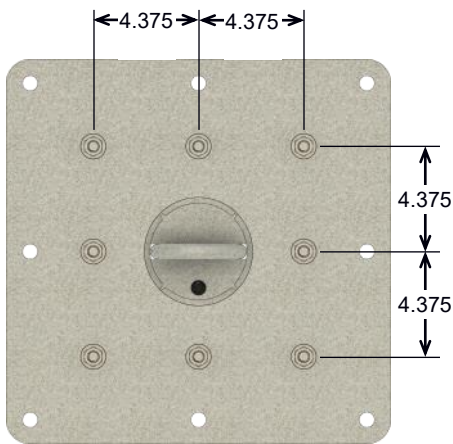
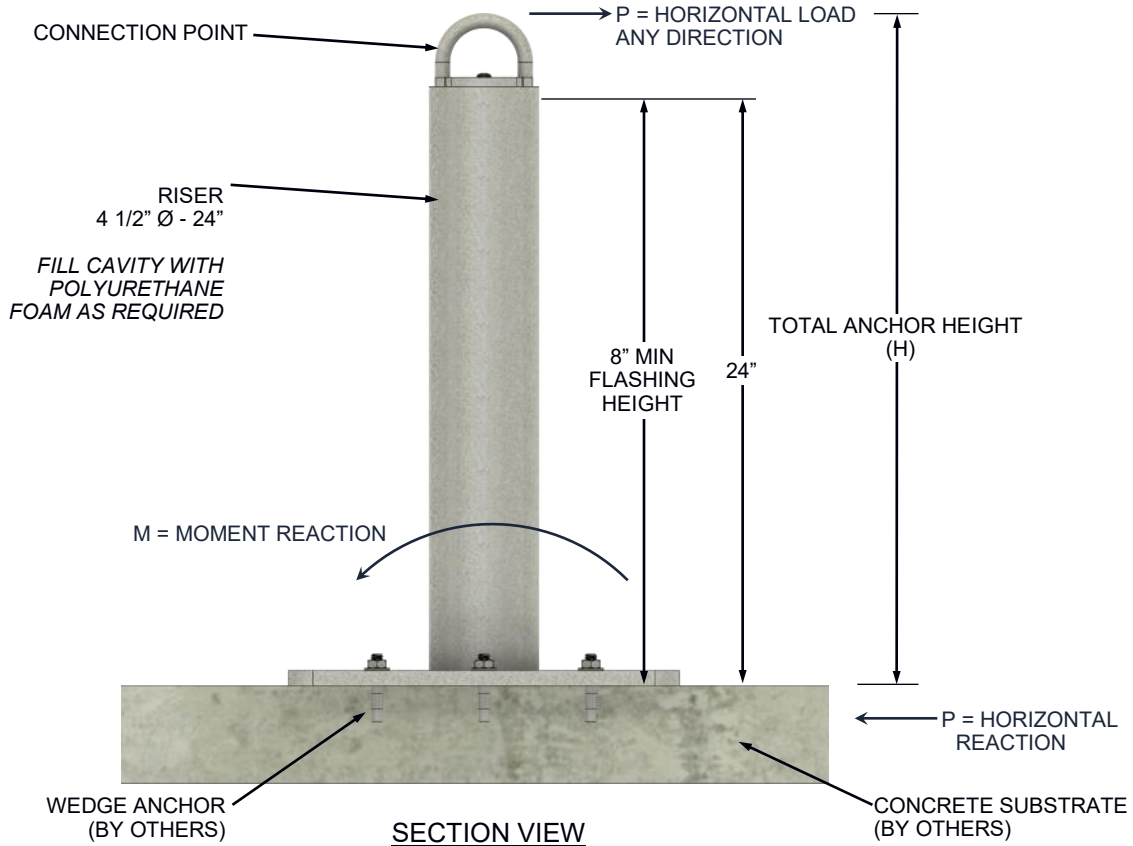

Materials

Riser:	24"	4" Schedule 40 pipe ASTM A53
Base Plate:	24"	0.625" x 16" x 16" ASTM A36
Riser Cap:	24"	0.375" x 4"Ø ASTM A36
Loop Top:	All	0.0625"Ø ASTM A36
Finish:		Hot-Dipped Galvanized ASTM A123

Structural Connections

- Design shall be approved by a qualified engineer to local standards and codes.
- Installation of field bolts shall be inspected in accordance with AISC guidelines.
- All welding shall conform to AWS code.
- All bolts shall be installed to a snug-fit condition, properly aligned with holes.
- All welds on drawing shall be shop weld.
- Welded connection shall have a minimum 5/16" fillet weld.
- Weld size on drawings is considered effective weld size and shall increase as required by skews or gaps between components in accordance with AWS.
- Reinforcing of structure to completed by other as required.

Design Loads

*All loads are factored

RISER	H (inches)	P (lbs)	M (in-lbs)
24"	27	5000	135000

ROOF ANCHOR POINT INSTRUCTION MANUAL

ENGLISH

Roof Anchor Point - 12" & 18" Concrete Thru-Bolt

FASTENERS REFERENCE
PAGE 25

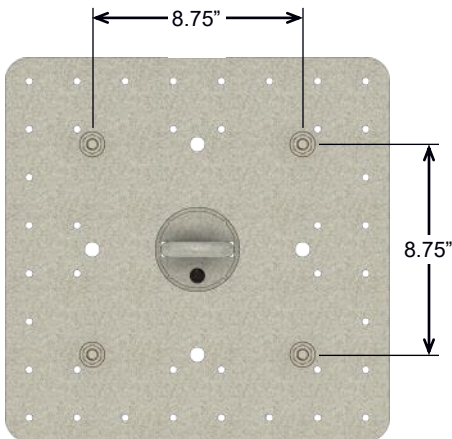
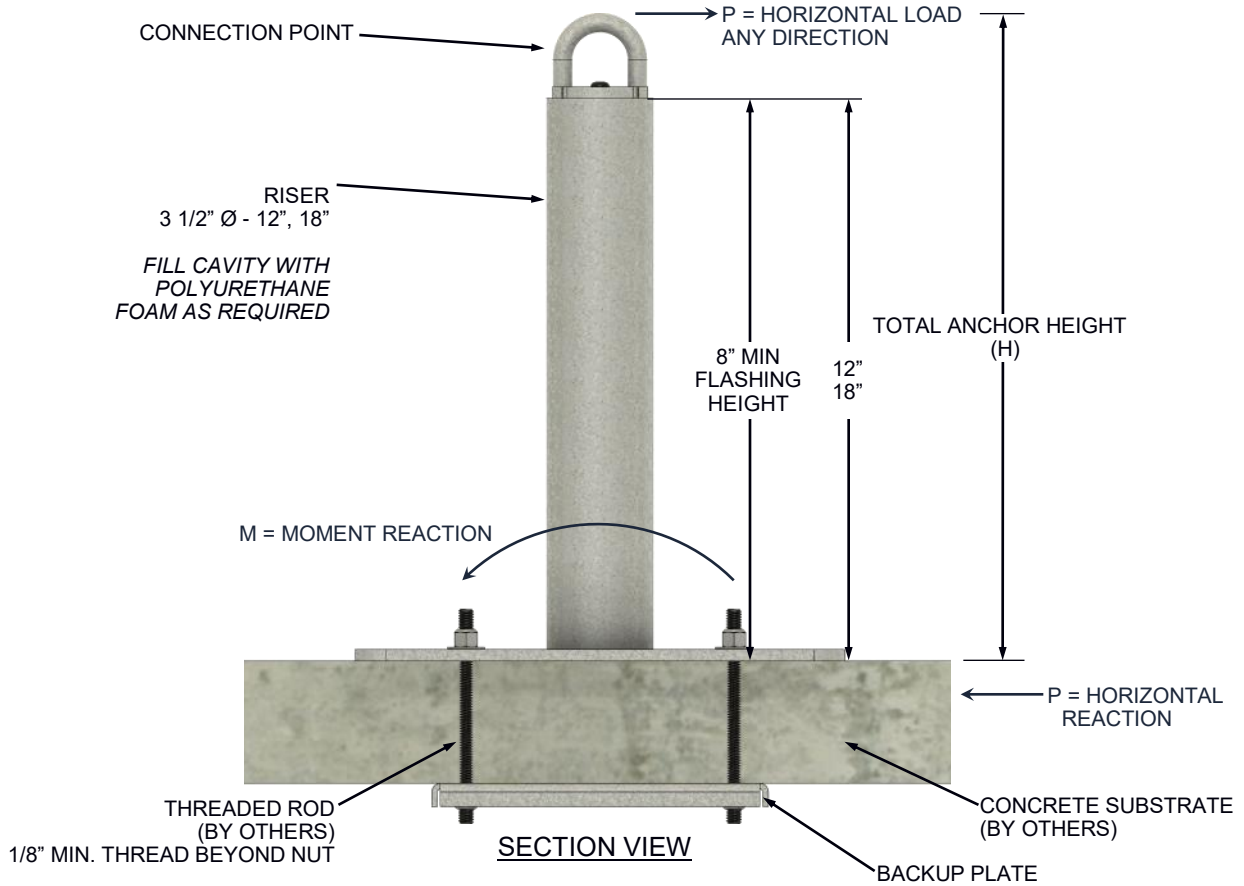

Materials

Riser:	12", 18"	3" Schedule 40 pipe ASTM A53
Base Plate:	12", 18"	0.375" x 16" x 16" ASTM A36
Backup Plate:		0.1875" x 10" x 10" ASTM A36
Riser Cap:	12", 18"	0.375" x 3.2"Ø ASTM A36
Loop Top:	All	0.0625"Ø ASTM A36
Finish:		Hot-Dipped Galvanized ASTM A123

Structural Connections

- Design shall be approved by a qualified engineer to local standards and codes.
- Installation of field bolts shall be inspected in accordance with AISC guidelines.
- All welding shall conform to AWS code.
- All bolts shall be installed to a snug-fit condition, properly aligned with holes.
- All welds on drawing shall be shop weld.
- Welded connection shall have a minimum 5/16" fillet weld.
- Weld size on drawings is considered effective weld size and shall increase as required by skews or gaps between components in accordance with AWS.
- Reinforcing of structure to completed by other as required.

Design Loads

*All loads are factored

RISER	H (inches)	P (lbs)	M (in-lbs)
12"	14.8	5000	74000
18"	20.8	5000	104000

ROOF ANCHOR POINT INSTRUCTION MANUAL

E
N
G
L
I
S
H

Roof Anchor Point - 12" & 18" Concrete Chemical Anchor

FASTENERS REFERENCE
PAGE 25

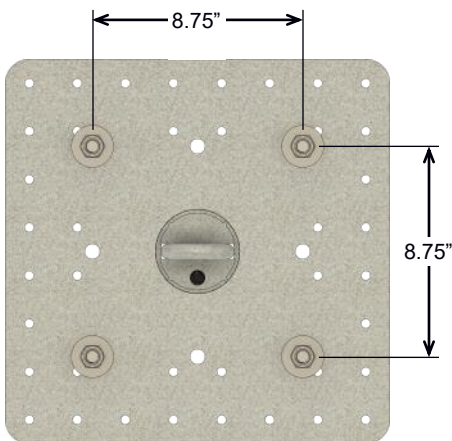
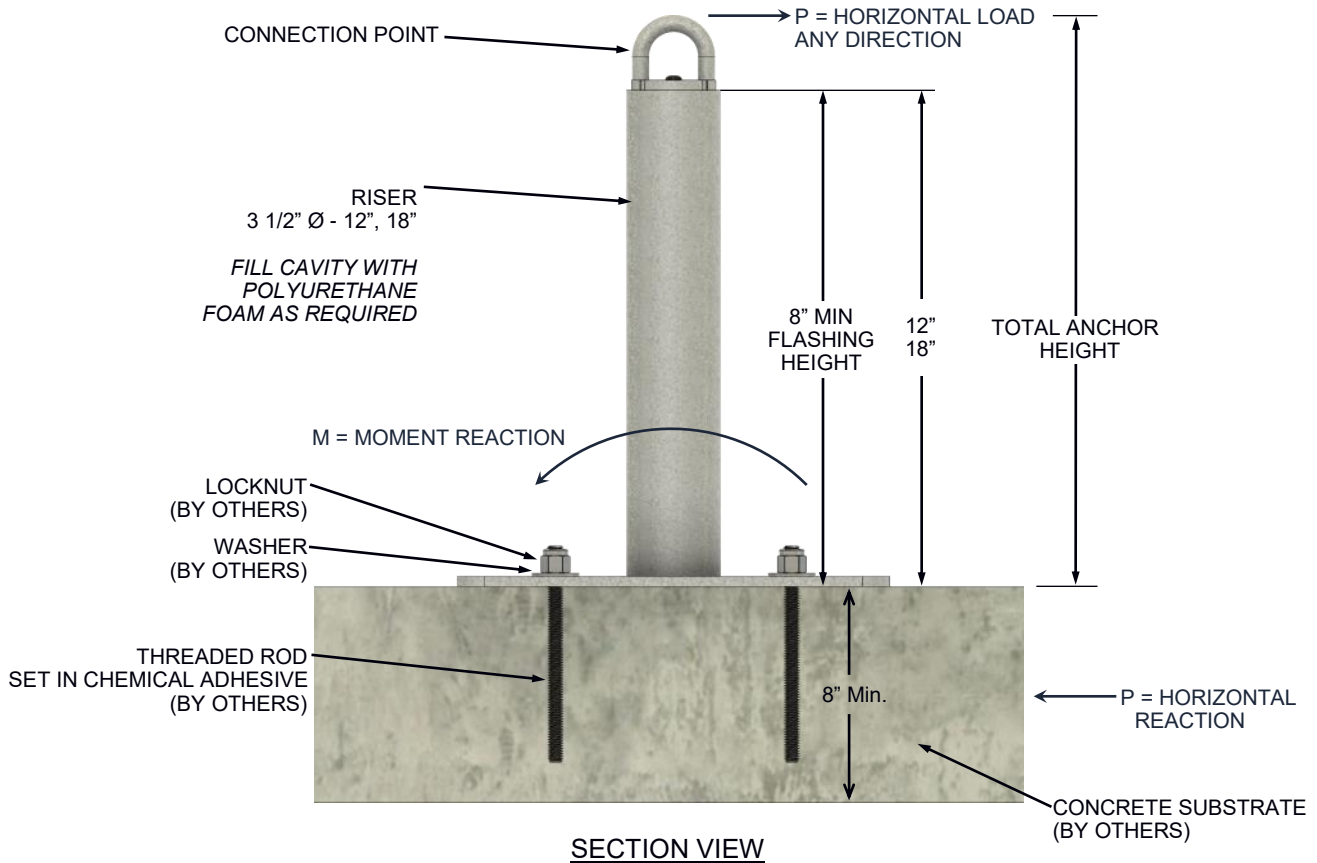

Materials

Riser:	12", 18"	3" Schedule 40 pipe ASTM A53
Base Plate:	12", 18"	0.375" x 16" x 16" ASTM A36
Backup Plate:		0.1875" x 10" x 10" ASTM A36
Riser Cap:	12", 18"	0.375" x 3.2"Ø ASTM A36
Loop Top:	All	0.0625"Ø ASTM A36
Finish:		Hot-Dipped Galvanized ASTM A123

Structural Connections

- Design shall be approved by a qualified engineer to local standards and codes.
- Installation of field bolts shall be inspected in accordance with AISC guidelines.
- All welding shall conform to AWS code.
- All bolts shall be installed to a snug-fit condition, properly aligned with holes.
- All welds on drawing shall be shop weld.
- Welded connection shall have a minimum 5/16" fillet weld.
- Weld size on drawings is considered effective weld size and shall increase as required by skews or gaps between components in accordance with AWS.
- Reinforcing of structure to completed by other as required.

Design Loads

*All loads are factored

RISER	H (inches)	P (lbs)	M (in-lbs)
12"	14.8	5000	74000
18"	20.8	5000	104000

ROOF ANCHOR POINT INSTRUCTION MANUAL

Roof Anchor Point - 12", 18" & 24" I-Beam Thru-Bolt

FASTENERS REFERENCE
PAGE 26

ENGLISH

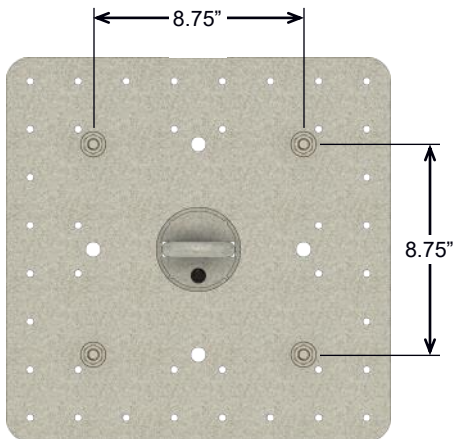
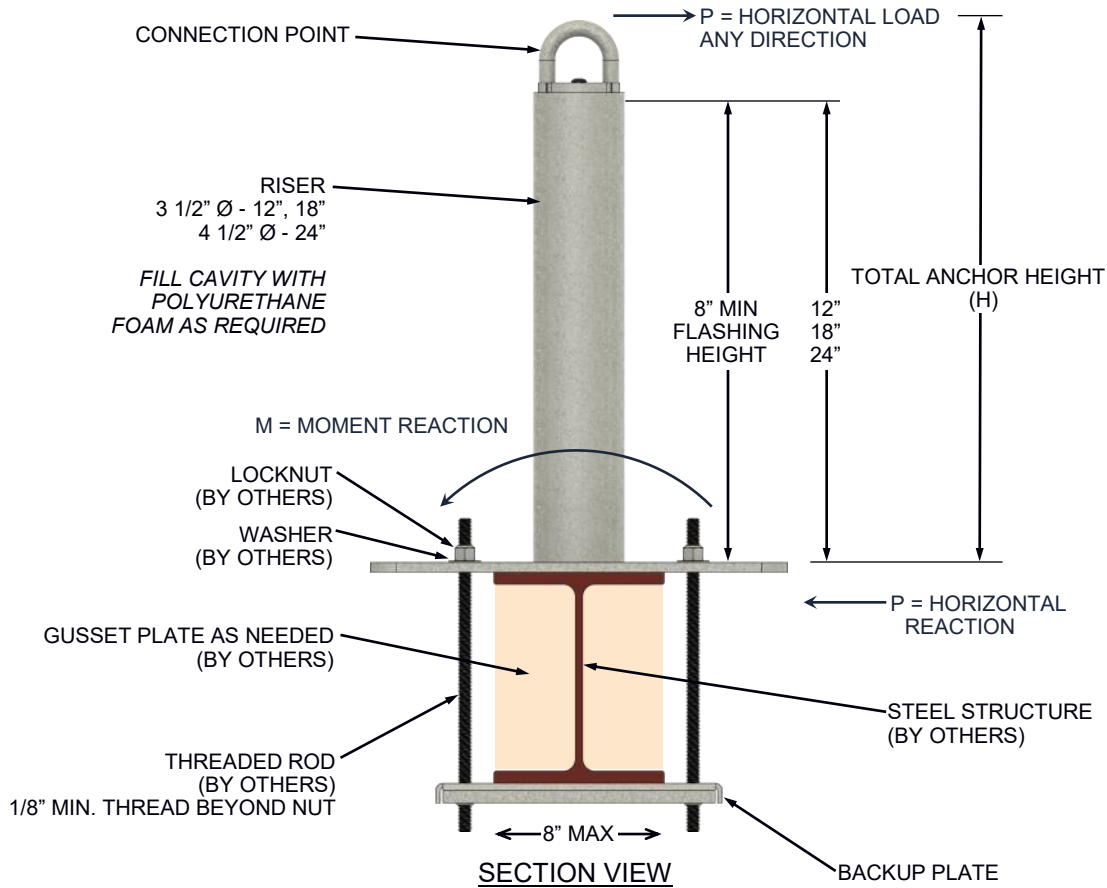

Materials

Risers:	12", 18" 24"	3" Schedule 40 pipe ASTM A53 4" Schedule 40 pipe ASTM A53
Base Plate:	12", 18" 24"	0.375" x 16" x 16" ASTM A36 0.625" x 16" x 16" ASTM A36
Backup Plate:		0.1875" x 10" x 10" ASTM A36
Riser Cap:	12", 18" 24"	0.375" x 3.2"Ø ASTM A36 0.375" x 4"Ø ASTM A36
Loop Top:	All	0.0625"Ø ASTM A36
Finish:		Hot-Dipped Galvanized ASTM A123

Structural Connections

- Design shall be approved by a qualified engineer to local standards and codes.
- Installation of field bolts shall be inspected in accordance with AISC guidelines.
- All welding shall conform to AWS code.
- All bolts shall be installed to a snug-fit condition, properly aligned with holes.
- All welds on drawing shall be shop weld.
- Welded connection shall have a minimum 5/16" fillet weld.
- Weld size on drawings is considered effective weld size and shall increase as required by skews or gaps between components in accordance with AWS.
- Reinforcing of structure to completed by other as required.

Design Loads

*All loads are factored

RISER	H (inches)	P (lbs)	M (in-lbs)
12"	14.8	5000	74000
18"	20.8	5000	104000
24"	27	5000	135000

ROOF ANCHOR POINT INSTRUCTION MANUAL

ENGLISH

Roof Anchor Point - 12", 18" & 24" I-Beam Welded

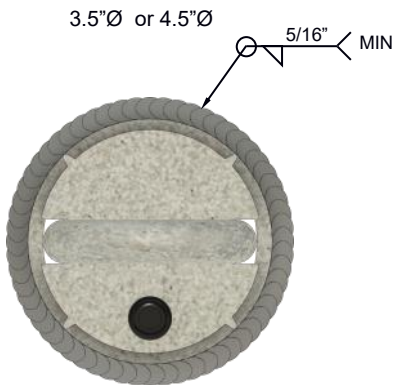
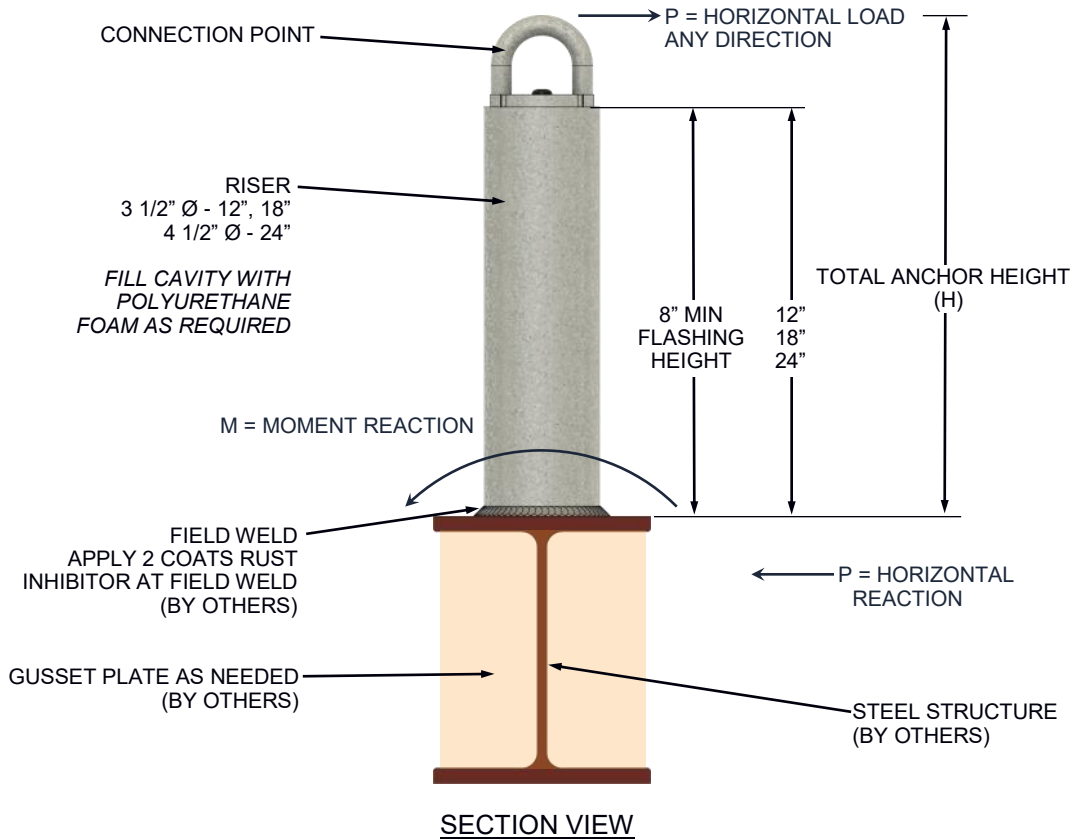

Materials

Risers:	12", 18" 24"	3" Schedule 40 pipe ASTM A53 4" Schedule 40 pipe ASTM A53
Riser Cap:	12", 18" 24"	0.375" x 3.2"Ø ASTM A36 0.375" x 4"Ø ASTM A36
Loop Top:	All	0.0625"Ø ASTM A36
Finish:		Hot-Dipped Galvanized ASTM A123

Structural Connections

- Design shall be approved by a qualified engineer to local standards and codes.
- Installation of field bolts shall be inspected in accordance with AISC guidelines.
- All welding shall conform to AWS code.
- All bolts shall be installed to a snug-fit condition, properly aligned with holes.
- All welds on drawing shall be shop weld.
- Welded connection shall have a minimum 5/16" fillet weld.
- Weld size on drawings is considered effective weld size and shall increase as required by skews or gaps between components in accordance with AWS.
- Reinforcing of structure to completed by other as required.

Design Loads

*All loads are factored

RISER	H (inches)	P (lbs)	M (in-lbs)
12"	14.8	5000	74000
18"	20.8	5000	104000
24"	27	5000	135000

ROOF ANCHOR POINT INSTRUCTION MANUAL

Roof Anchor Point - 12" Riser 22ga Min. Metal Deck

FASTENERS REFERENCE
PAGE 25

E
N
G
L
I
S
H

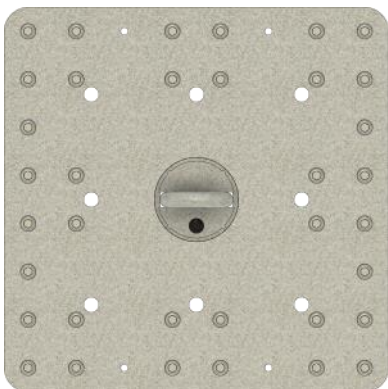
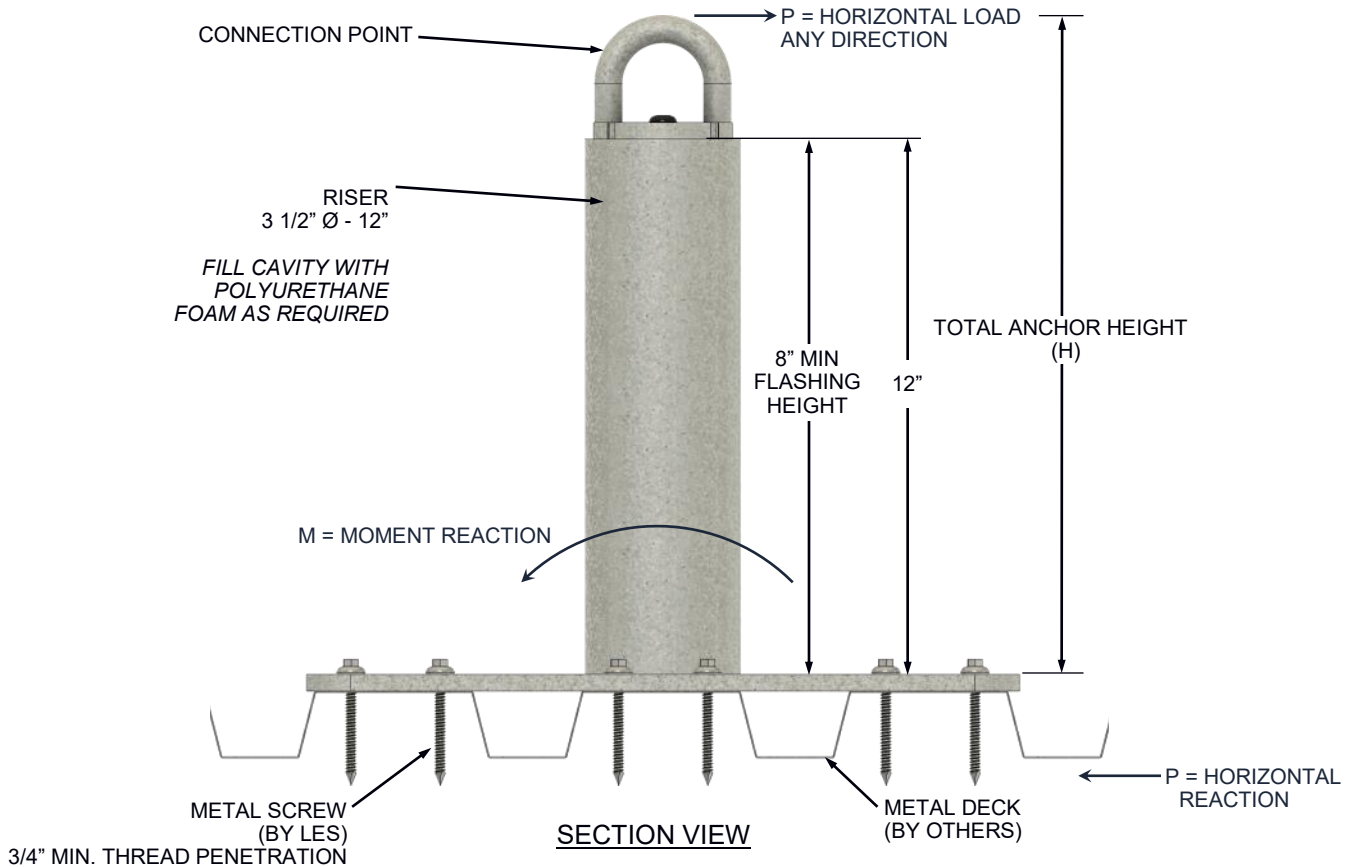

Materials

Riser:	12"	3" Schedule 40 pipe ASTM A53
Base Plate:	12"	0.375" x 16" x 16" ASTM A36
Riser Cap:	12"	0.375" x 3.2"Ø ASTM A36
Loop Top:	All	0.625"Ø ASTM A36
Finish:		Hot-Dipped Galvanized ASTM A123

Structural Connections

- Design shall be approved by a qualified engineer to local standards and codes.
- Installation of field bolts shall be inspected in accordance with AISC guidelines.
- All welding shall conform to AWS code.
- All bolts shall be installed to a snug-fit condition, properly aligned with holes.
- All welds on drawing shall be shop weld.
- Welded connection shall have a minimum 5/16" fillet weld.
- Weld size on drawings is considered effective weld size and shall increase as required by skews or gaps between components in accordance with AWS.
- Reinforcing of structure to completed by other as required.

Design Loads

*All loads are factored

RISER	H (inches)	P (lbs)	M (in-lbs)
12"	14.8	5000	74000

ROOF ANCHOR POINT INSTRUCTION MANUAL

ENGLISH

Roof Anchor Point - 12" Riser Less Than 22ga Metal Deck

FASTENERS REFERENCE
PAGE 27

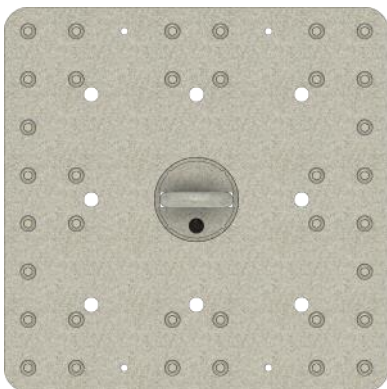
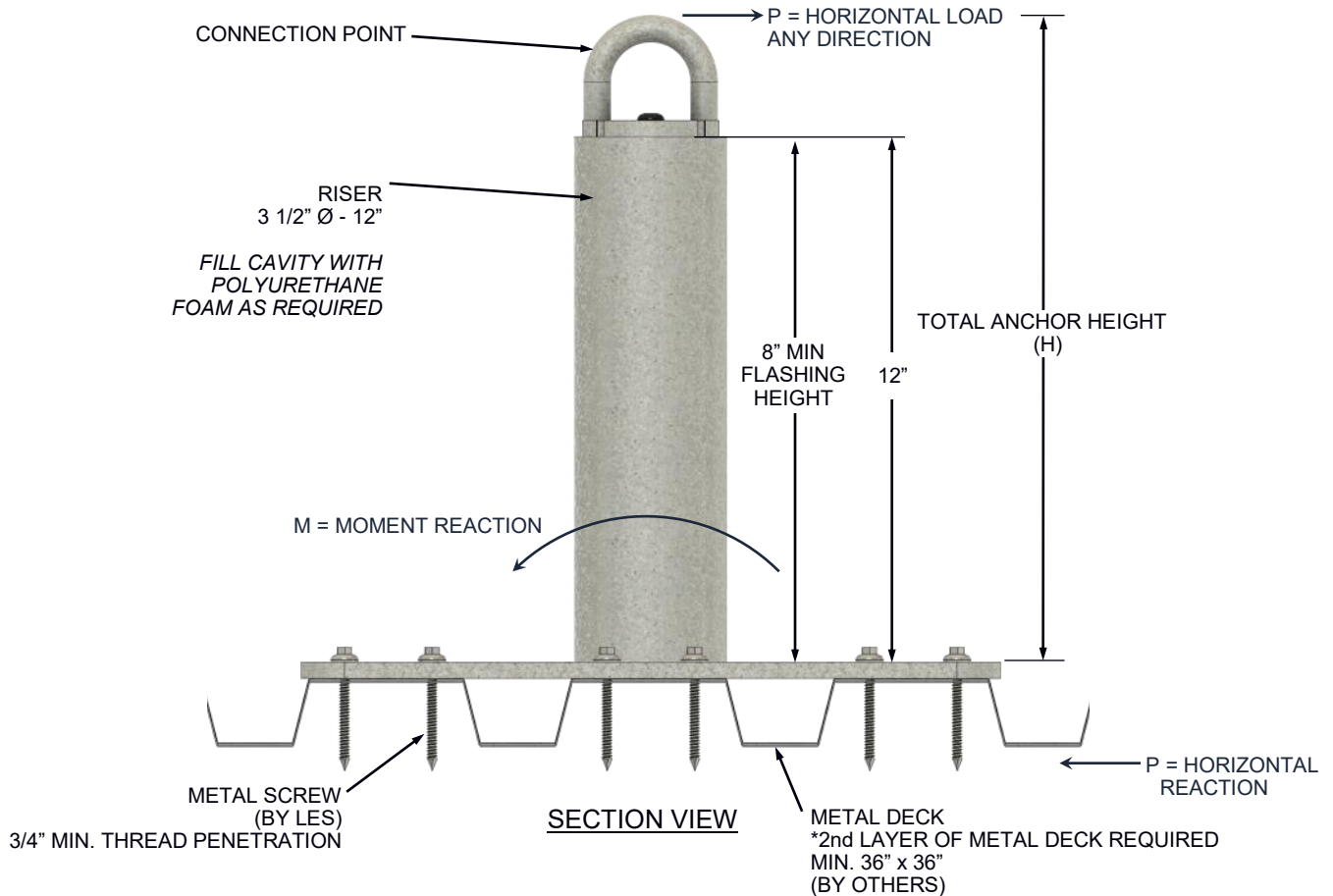

Materials

Riser:	12"	3" Schedule 40 pipe ASTM A53
Base Plate:	12"	0.375" x 16" x 16" ASTM A36
Riser Cap:	12"	0.375" x 3.2"Ø ASTM A36
Loop Top:	All	0.625"Ø ASTM A36
Finish:		Hot-Dipped Galvanized ASTM A123

Structural Connections

- Design shall be approved by a qualified engineer to local standards and codes.
- Installation of field bolts shall be inspected in accordance with AISC guidelines.
- All welding shall conform to AWS code.
- All bolts shall be installed to a snug-fit condition, properly aligned with holes.
- All welds on drawing shall be shop weld.
- Welded connection shall have a minimum 5/16" fillet weld.
- Weld size on drawings is considered effective weld size and shall increase as required by skews or gaps between components in accordance with AWS.
- Reinforcing of structure to completed by other as required.

Design Loads

*All loads are factored

RISER	H (inches)	P (lbs)	M (in-lbs)
12"	14.8	5000	74000

ROOF ANCHOR POINT INSTRUCTION MANUAL

Roof Anchor Point - 12" & 18" Riser 22ga Min. Metal Deck, Insulation, OSB

FASTENERS REFERENCE
PAGE 27

E
N
G
L
I
S
H

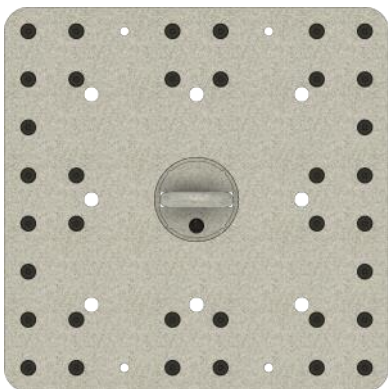
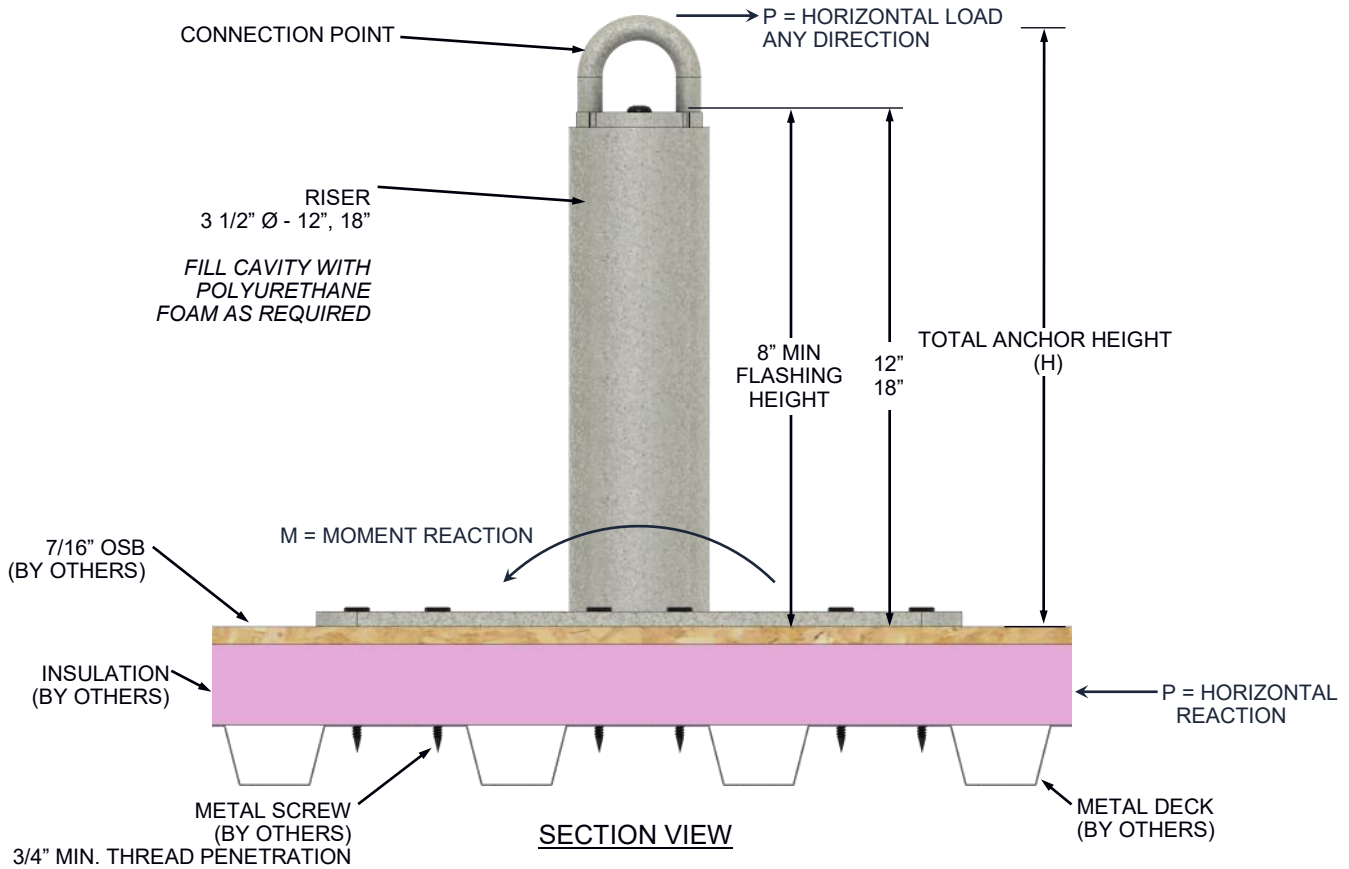

Design Loads

*All loads are factored

RISER	H (inches)	P (lbs)	M (in-lbs)
12"	14.8	5000	74000
18"	20.8	5000	104000

Materials

Riser:	12", 18"	3" Schedule 40 pipe ASTM A53
Base Plate:	12", 18"	0.375" x 16" x 16" ASTM A36
Riser Cap:	12", 18"	0.375" x 3.2"Ø ASTM A36
Loop Top:	All	0.625"Ø ASTM A36
Finish:		Hot-Dipped Galvanized ASTM A123

Structural Connections

- Design shall be approved by a qualified engineer to local standards and codes.
- Installation of field bolts shall be inspected in accordance with AISC guidelines.
- All welding shall conform to AWS code.
- All bolts shall be installed to a snug-fit condition, properly aligned with holes.
- All welds on drawing shall be shop weld.
- Welded connection shall have a minimum 5/16" fillet weld.
- Weld size on drawings is considered effective weld size and shall increase as required by skews or gaps between components in accordance with AWS.
- Reinforcing of structure to completed by other as required.

ROOF ANCHOR POINT INSTRUCTION MANUAL

ENGLISH

Roof Anchor Point - 12" & 18" Riser All Metal Decks

FASTENERS REFERENCE
PAGE 27

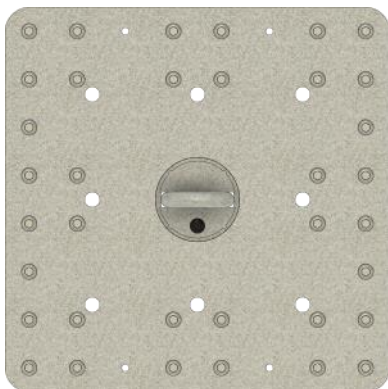
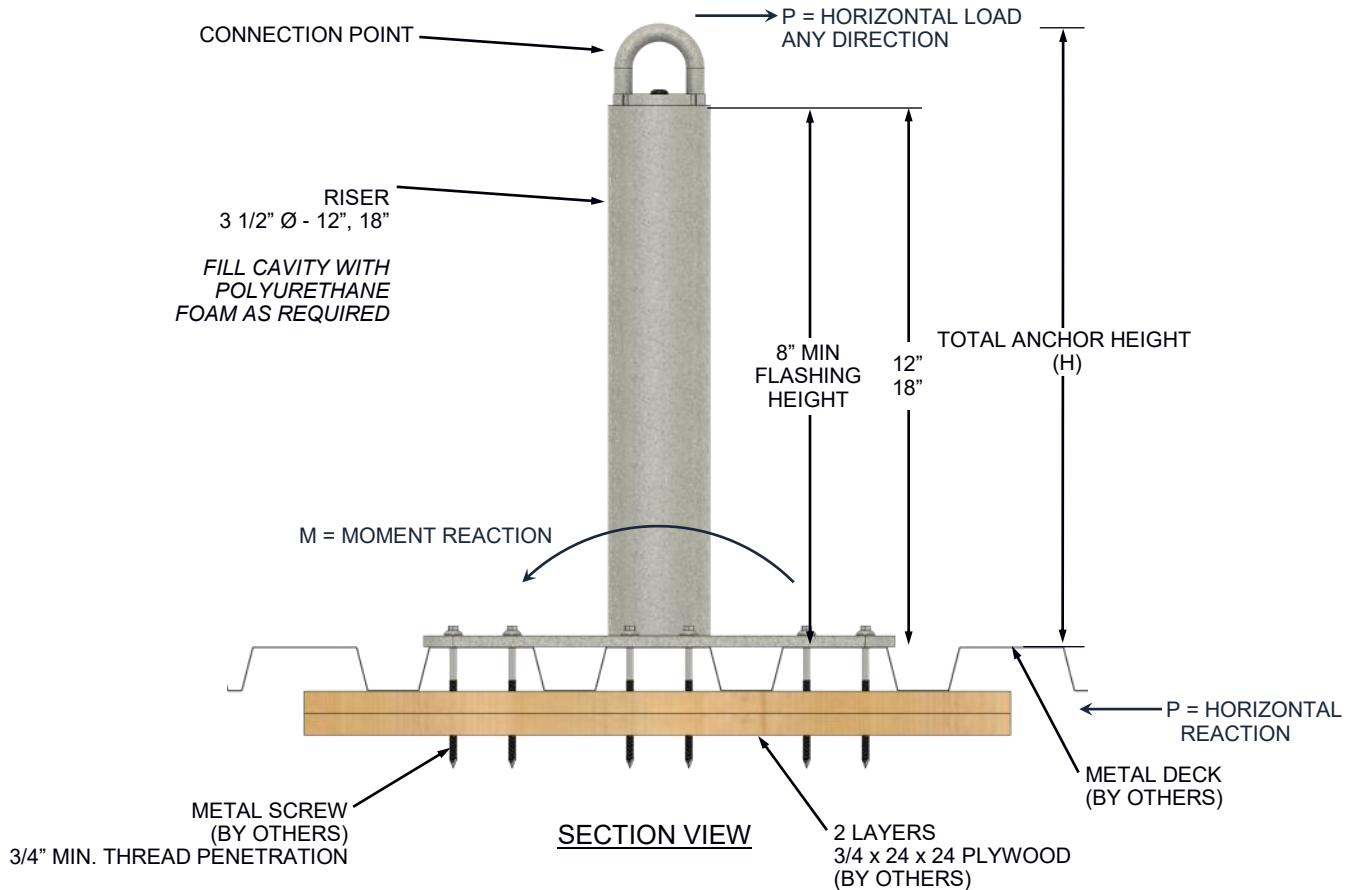

Materials

Riser:	12", 18"	3" Schedule 40 pipe ASTM A53
Base Plate:	12", 18"	0.375" x 16" x 16" ASTM A36
Riser Cap:	12", 18"	0.375" x 3.2"Ø ASTM A36
Loop Top:	All	0.625"Ø ASTM A36
Finish:		Hot-Dipped Galvanized ASTM A123

Structural Connections

- Design shall be approved by a qualified engineer to local standards and codes.
- Installation of field bolts shall be inspected in accordance with AISC guidelines.
- All welding shall conform to AWS code.
- All bolts shall be installed to a snug-fit condition, properly aligned with holes.
- All welds on drawing shall be shop weld.
- Welded connection shall have a minimum 5/16" fillet weld.
- Weld size on drawings is considered effective weld size and shall increase as required by skewers or gaps between components in accordance with AWS.
- Reinforcing of structure to completed by other as required.

Design Loads

*All loads are factored

RISER	H (inches)	P (lbs)	M (in-lbs)
12"	14.8	5000	74000
18"	20.8	5000	104000

ROOF ANCHOR POINT INSTRUCTION MANUAL

Roof Anchor Point - 12" & 18" Riser 3/4" Plywood Deck

FASTENERS REFERENCE
PAGE 28

E
N
G
L
I
S
H

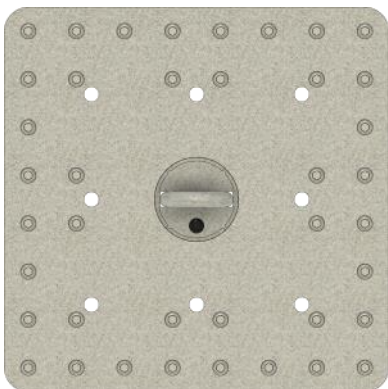
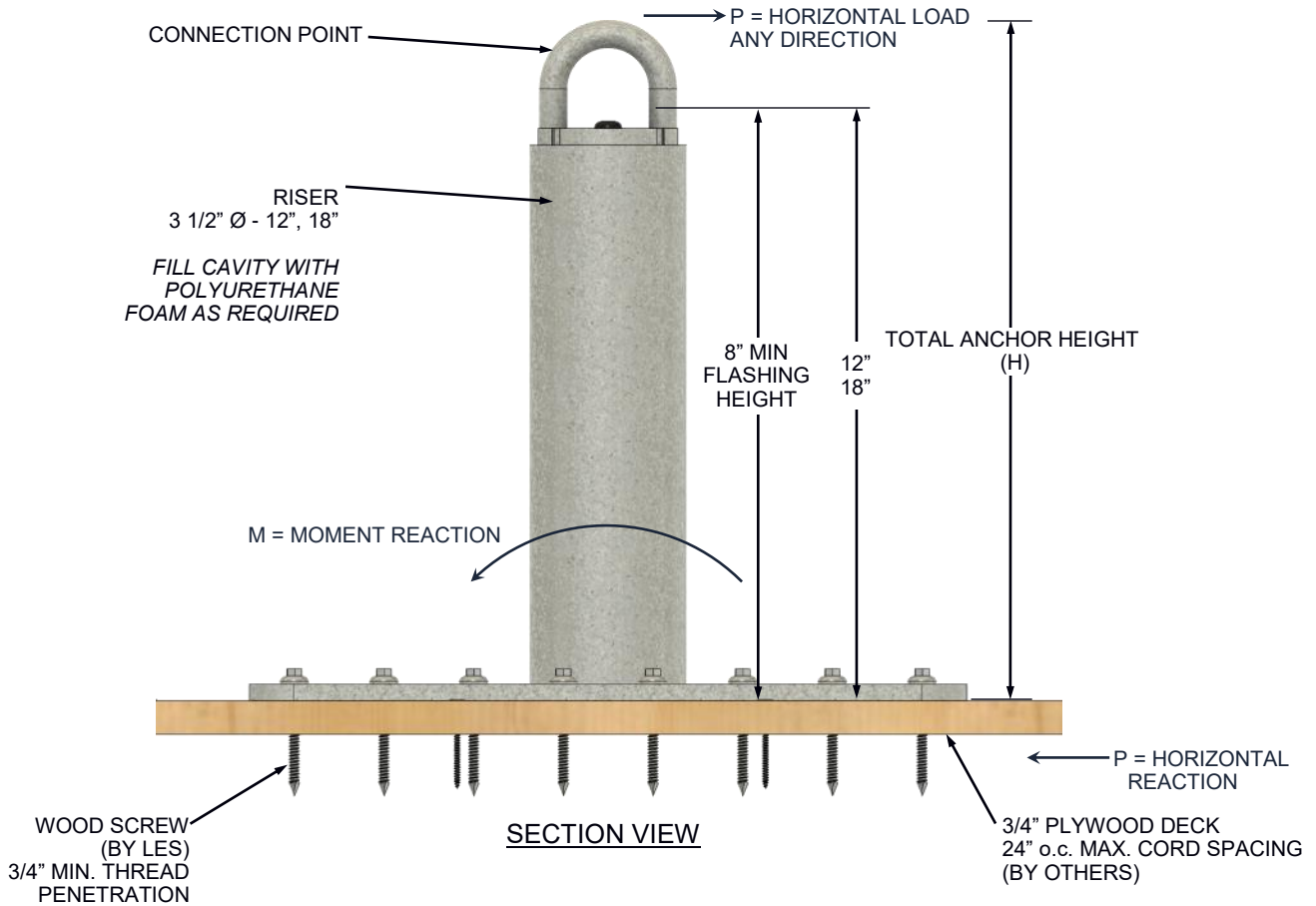

Materials

Riser:	12", 18"	3" Schedule 40 pipe ASTM A53
Base Plate:	12", 18"	0.375" x 16" x 16" ASTM A36
Riser Cap:	12", 18"	0.375" x 3.2"Ø ASTM A36
Loop Top:	All	0.625"Ø ASTM A36
Finish:		Hot-Dipped Galvanized ASTM A123

Structural Connections

- Design shall be approved by a qualified engineer to local standards and codes.
- Installation of field bolts shall be inspected in accordance with AISC guidelines.
- All welding shall conform to AWS code.
- All bolts shall be installed to a snug-fit condition, properly aligned with holes.
- All welds on drawing shall be shop weld.
- Welded connection shall have a minimum 5/16" fillet weld.
- Weld size on drawings is considered effective weld size and shall increase as required by skews or gaps between components in accordance with AWS.
- Reinforcing of structure to completed by other as required.

Design Loads

*All loads are factored

RISER	H (inches)	P (lbs)	M (in-lbs)
12"	14.8	5000	74000
18"	20.8	5000	104000

ROOF ANCHOR POINT INSTRUCTION MANUAL

ENGLISH

Roof Anchor Point - 12" & 18" Riser 1/2" Plywood or 7/16" OSB Deck

FASTENERS REFERENCE
PAGE 28

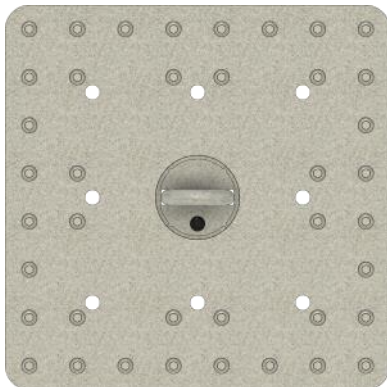
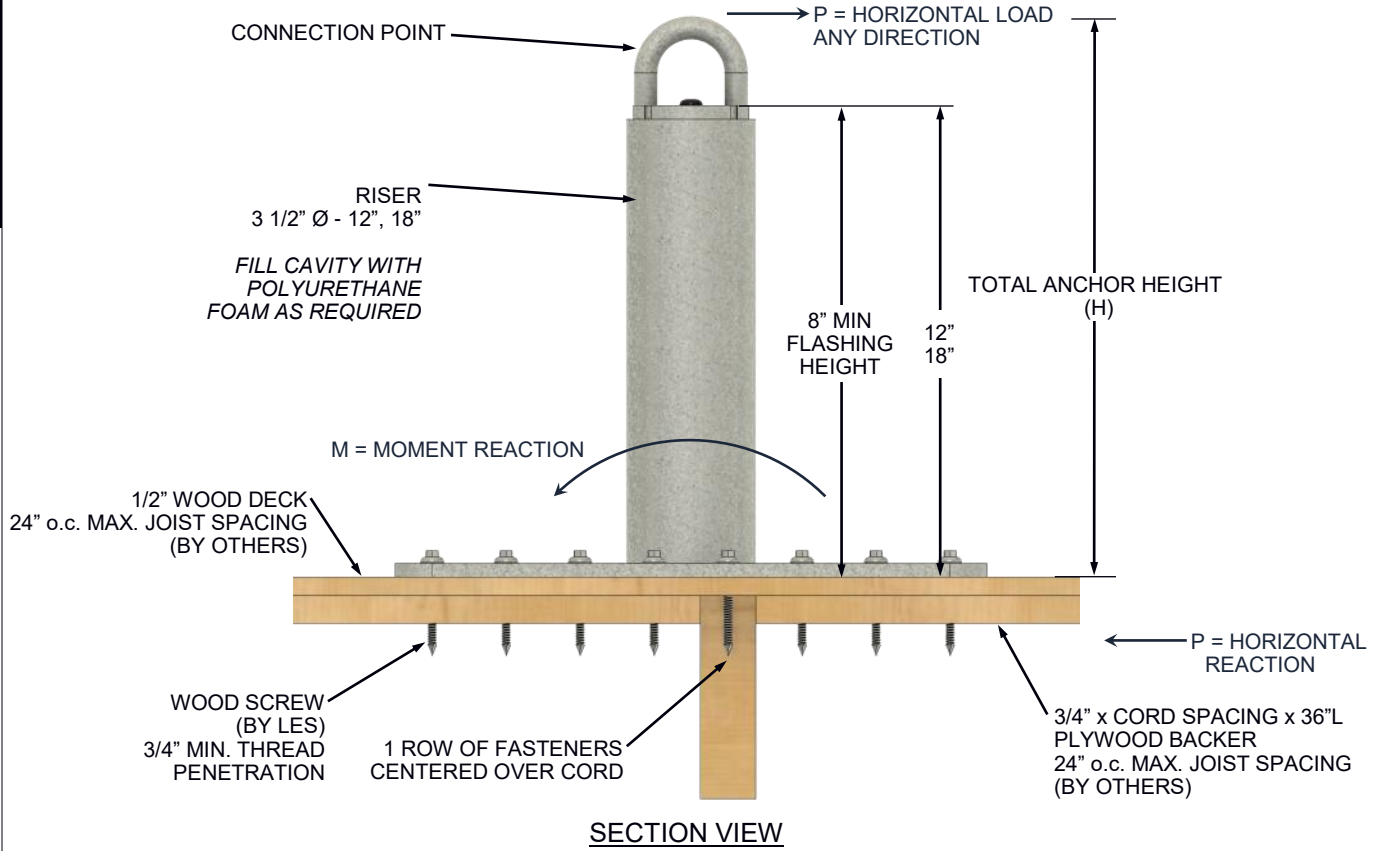

Materials

Riser:	12", 18"	3" Schedule 40 pipe ASTM A53
Base Plate:	12", 18"	0.375" x 16" x 16" ASTM A36
Riser Cap:	12", 18"	0.375" x 3.2"Ø ASTM A36
Loop Top:	All	0.625"Ø ASTM A36
Finish:		Hot-Dipped Galvanized ASTM A123

Design Loads

*All loads are factored

RISER	H (inches)	P (lbs)	M (in-lbs)
12"	14.8	5000	74000
18"	20.8	5000	104000

Structural Connections

- Design shall be approved by a qualified engineer to local standards and codes.
- Installation of field bolts shall be inspected in accordance with AISC guidelines.
- All welding shall conform to AWS code.
- All bolts shall be installed to a snug-fit condition, properly aligned with holes.
- All welds on drawing shall be shop weld.
- Welded connection shall have a minimum 5/16" fillet weld.
- Weld size on drawings is considered effective weld size and shall increase as required by skews or gaps between components in accordance with AWS.
- Reinforcing of structure to completed by other as required.

ROOF ANCHOR POINT INSTRUCTION MANUAL

E
N
G
L
I
S
H

Roof Anchor Point - 12" & 18" Riser Sandwich Roof Assembly

FASTENERS REFERENCE
PAGE 28

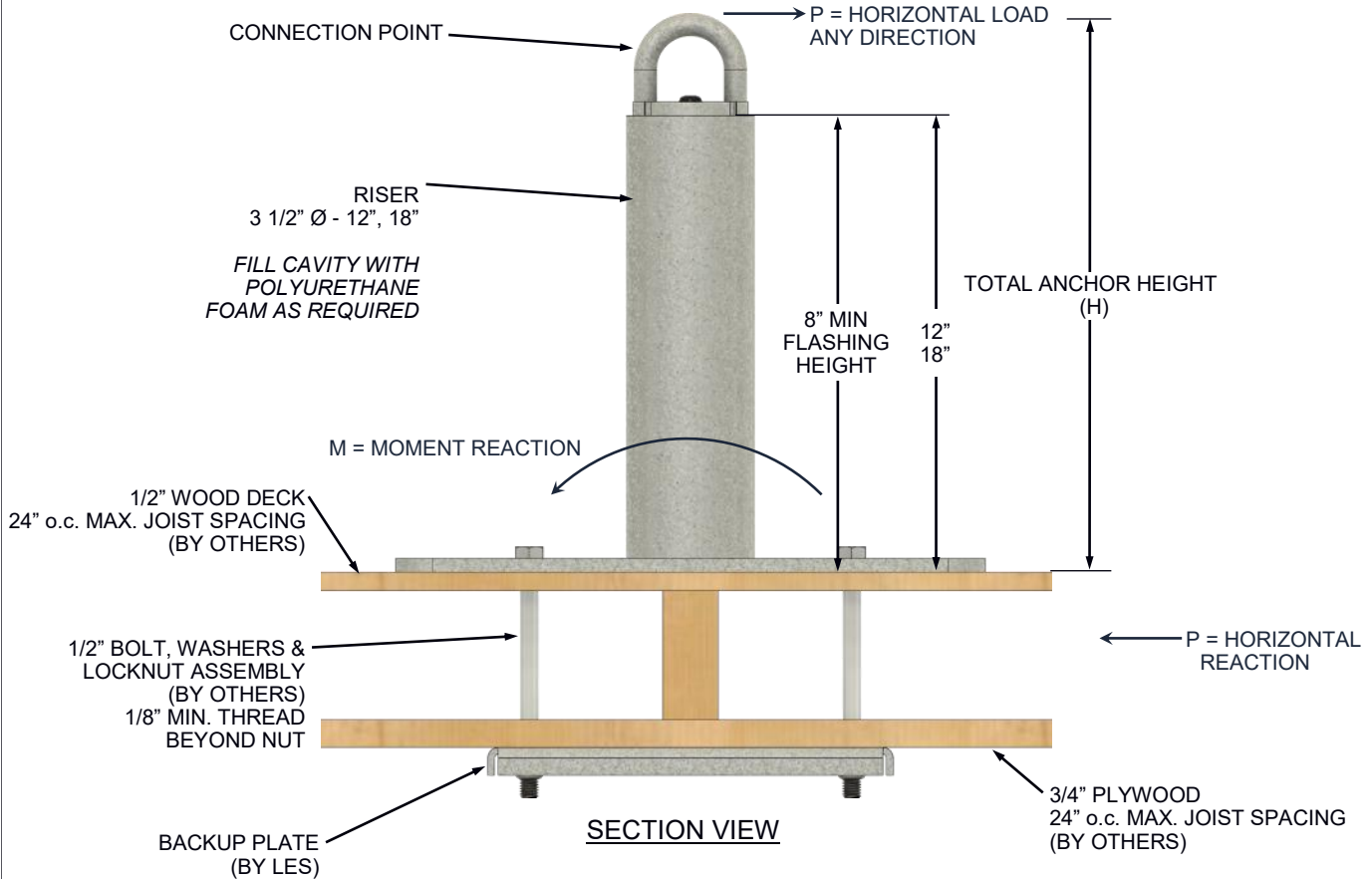

Materials

Riser:	12", 18"	3" Schedule 40 pipe ASTM A53
Base Plate:	12", 18"	0.375" x 16" x 16" ASTM A36
Riser Cap:	12", 18"	0.375" x 3.2"Ø ASTM A36
Loop Top:	All	0.625"Ø ASTM A36
Finish:		Hot-Dipped Galvanized ASTM A123

Structural Connections

- Design shall be approved by a qualified engineer to local standards and codes.
- Installation of field bolts shall be inspected in accordance with AISC guidelines.
- All welding shall conform to AWS code.
- All bolts shall be installed to a snug-fit condition, properly aligned with holes.
- All welds on drawing shall be shop weld.
- Welded connection shall have a minimum 5/16" fillet weld.
- Weld size on drawings is considered effective weld size and shall increase as required by skews or gaps between components in accordance with AWS.
- Reinforcing of structure to completed by other as required.

Design Loads

*All loads are factored

RISER	H (inches)	P (lbs)	M (in-lbs)
12"	14.8	5000	74000
18"	20.8	5000	104000

ROOF ANCHOR POINT INSTRUCTION MANUAL

ENGLISH

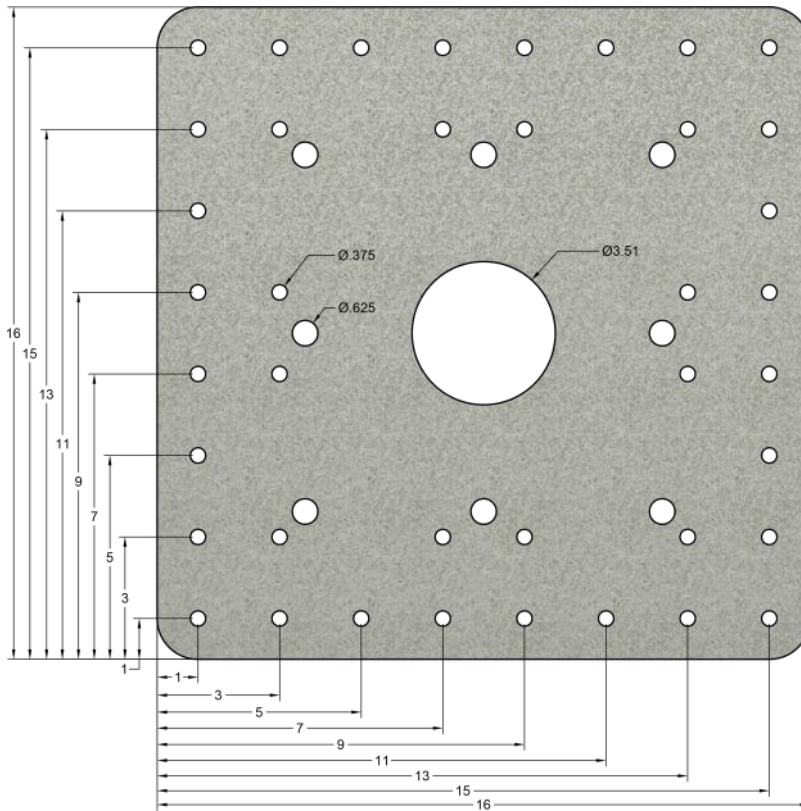

12" & 18" RISER BASE PLATE DIMENSIONS

3/8" x 16" x 16"

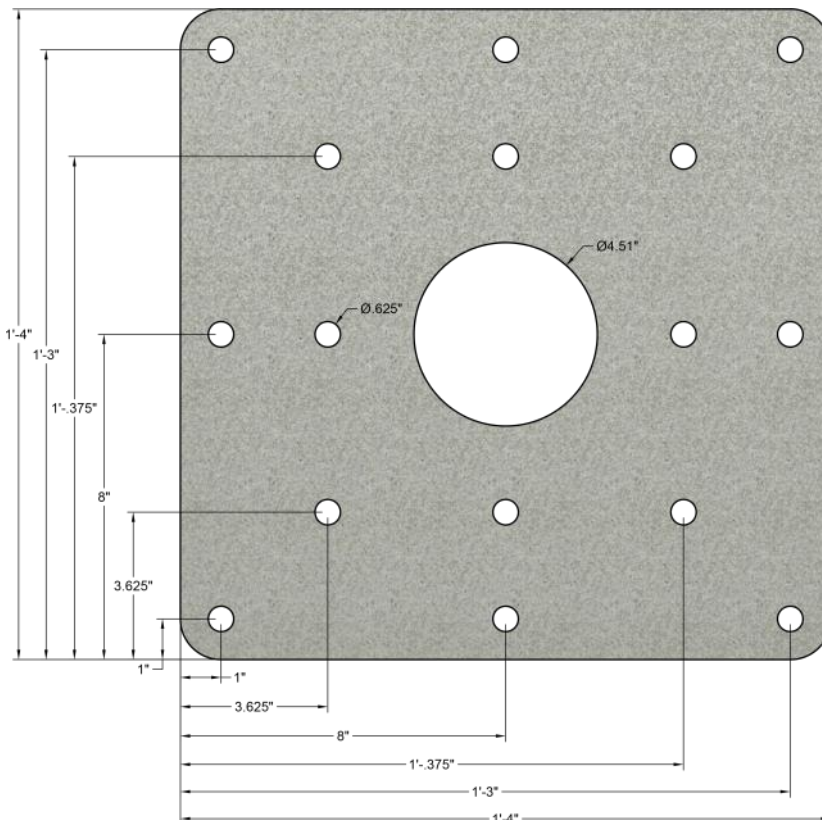

24" RISER BASE PLATE DIMENSIONS

5/8" x 16" x 16"

ROOF ANCHOR POINT INSTRUCTION MANUAL

E
N
G
L
I
S
H

Concrete Applications

Concrete Screw Anchor

Page 7 - 12" & 18" Riser
Page 8 - 24" Riser

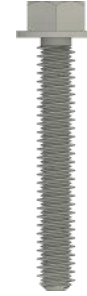

1/2" Large Diameter Tapcon (LDT) or Equivalent

Model	Min. Embedment	
	4 Bolt	8 Bolt
RAP-12-1616-23	3.75	N/A
RAP-18-1616-23	5.5	3.5
RAP-24-1616-23	6.875	4.5

Poured-in-place J-bolts may be used in lieu of concrete anchors.

Concrete Wedge Anchor

Page 9 - 12" & 18" Riser
Page 10 - 24" Riser



1/2" Wedge Anchor

Model	Min. Embedment	
	4 Bolt	8 Bolt
RAP-12-1616-23	3.75	N/A
RAP-18-1616-23	5.5	3.5
RAP-24-1616-23	6.875	4.5

Poured-in-place J-bolts may be used in lieu of concrete anchors.

Concrete Thru-Bolt

Page 11 - 12" & 18" Riser
Page 12 - 24" Riser

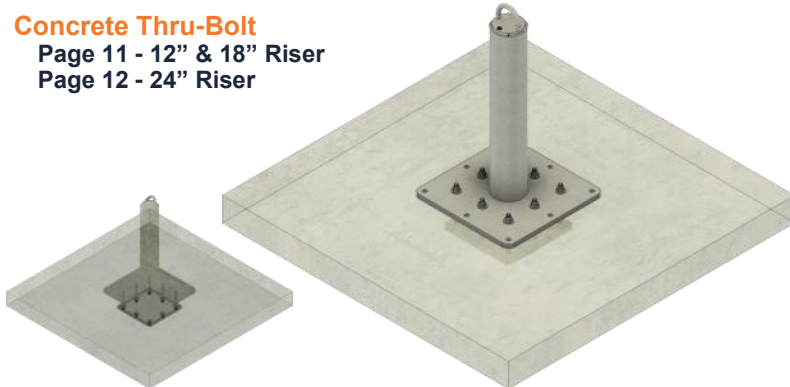

1/2" Bolt, Nut & Washer Grade 8

OR



1/2" Threaded Rod, Nut & Washer Grade 8

Concrete Chemical Anchor

Page 13 - 12" & 18" Riser



1/2" Hilti HAS-R or Equivalent

+



Hilti HY 200 or Equivalent

ROOF ANCHOR POINT INSTRUCTION MANUAL

I-Beam Applications

I-Beam Thru-Bolt

Page 14 - 12", 18" & 24" Riser

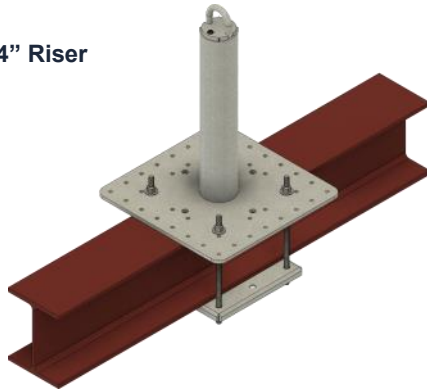

OR



1/2" Bolt, Nut & Washer
Grade 8

1/2" Threaded Rod, Nut
& Washer Grade 8

I-Beam Welded

Page 15 - 12", 18" & 24" Riser

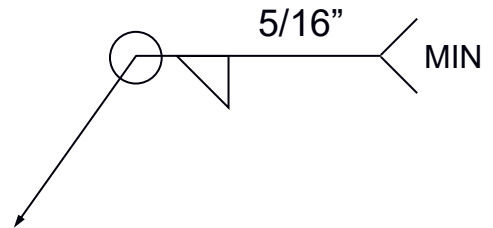
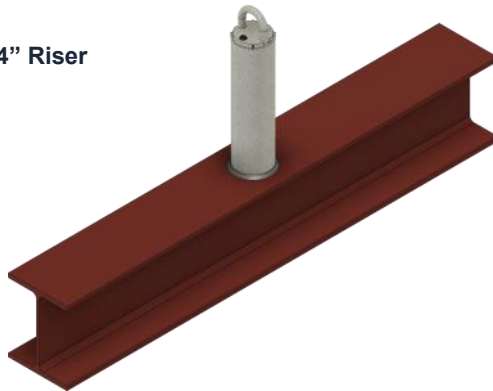

ROOF ANCHOR POINT INSTRUCTION MANUAL

E
N
G
L
I
S
H

Metal Deck Applications

Metal Deck - 22ga Min
Page 16 - 12" Riser

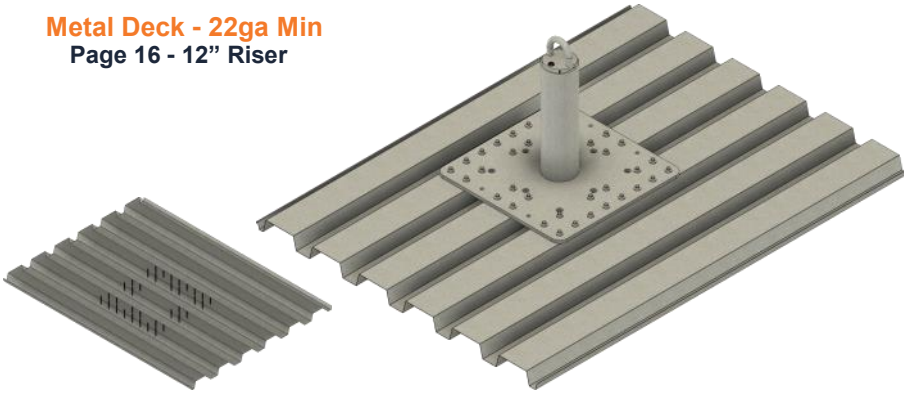

#14 Hex Head Screw

OR



3/16" HeadLok Screw
or equivalent

Metal Deck - Less Than 22ga
Page 17 - 12" Riser

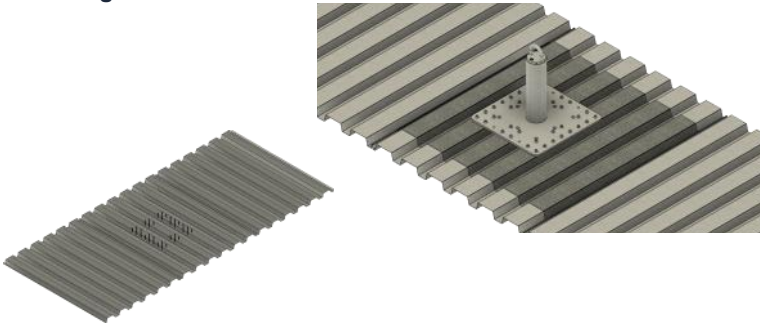

#14 Hex Head Screw

OR



3/16" HeadLok Screw
or equivalent

Metal Deck - Insulation & OSB
Page 18 - 12" & 18" Riser

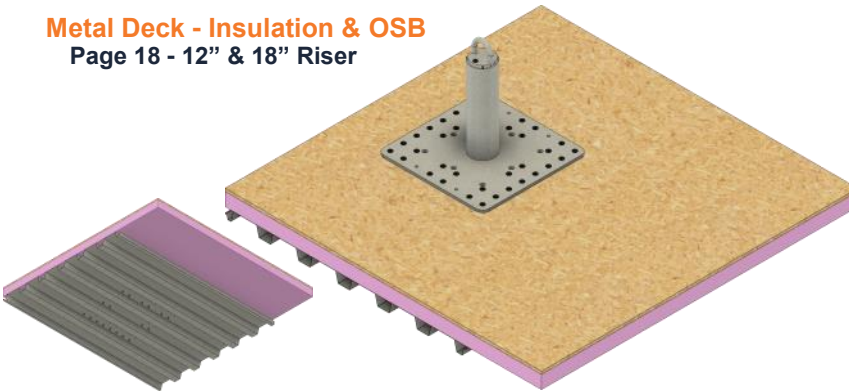

#14 Hex Head Screw

OR



3/16" HeadLok Screw
or equivalent

Metal Deck - Any Gauge
Page 19 - 12" & 18" Riser

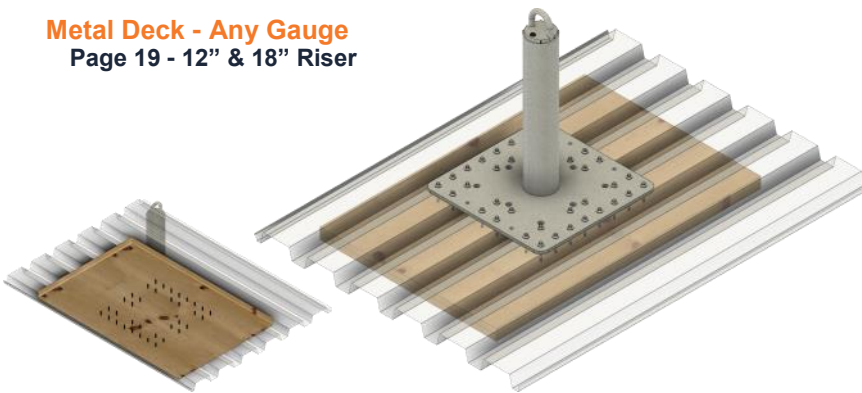

#14 Hex Head Screw

OR



3/16" HeadLok Screw
or equivalent

ROOF ANCHOR POINT INSTRUCTION MANUAL

Wood Deck Applications

**Wood Deck - 3/4" Plywood Min.
24" o.c. Cord Spacing**
Page 20 - 12" & 18" Riser



#14 Hex Head Screw

OR



3/16" HeadLok Screw
or equivalent

**Wood Deck - 1/2" Plywood
or 7/16" OSB, 16" o.c. Cord
Spacing**
Page 21 - 12" & 18" Riser



#14 Hex Head Screw

OR



3/16" HeadLok Screw
or equivalent

**Wood Deck - Thru-Bolt
Sandwiched Cords**
Page 22 - 12" & 18" Riser

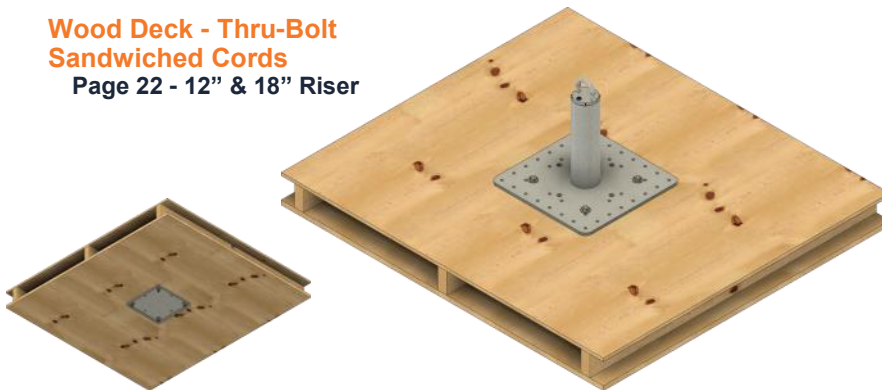

1/2" Bolt, Nut & Washer
Grade 8

OR



1/2" Threaded Rod, Nut
& Washer Grade 8

ROOF ANCHOR POINT INSTRUCTION MANUAL

4.0 Use and Limitations

4.1 Roof Anchor Points are designed for use as a single-user anchor point with a maximum user weight of 340 lbs, including the user, tools, and equipment.

4.1a The structural attachment point for the Roof Anchor Point must be capable of supporting 5,000lb or 2x the intended load when used as a fall arrest anchor or Maximum Arresting Force (MAF) of 1,800lbs (8.0kN) when used and installed according to product installation instructions and designed by qualified person.

4.1b Structural attachment locations shall be specified by the project engineer, architect or safety consultant. In general, single-user anchor points are spaced every 20-30 feet. and window washing anchors are spaced 12 feet or less.

4.1c Roof Anchor Points may be installed inverted or vertical as specified by a qualified person.

4.1d Risers over 18 inches in height shall be bolted, concrete embedded, or field welded unless otherwise specified by a qualified person.

4.2 Roof Anchor Points may be used as an anchorage for suspended component/tie-back or as an active fall protection system when designed by a qualified person.

4.2a Roof Anchor Points used for window washing anchors must be proof loaded to 2,500lbs by a qualified person. Note: Anchors attached to metal or wood substrates may flex when proof loaded. Risers should return to vertical position when load tension is released

4.2b Structural attachment locations shall be specified by the project engineer, architect or safety consultant. In general, window washing anchors are spaced 12 feet or less.

4.2c Risers used for window washing anchors shall be bolted, concrete embedded, or field welded unless otherwise specified by a qualified person.

4.2d Roof Anchor Points may be installed inverted or vertical as specified by a qualified person.

4.2f ANSI/IWCA.1-14.1 applicable standards:

4.2f.1 Analysis of the structural supporting member shall be performed by a registered engineer.

4.2f.2 Anchorage used for fall arrest shall be independent from anchorage used for the suspension system.

4.2f.3 Maximum angle for fall arrest shall not exceed 15° from perpendicular.

4.2f.4 Workers may not reach more than 6 feet left or right from the drop point.

4.2f.5 Maximum spacing between anchors is 12 feet.

4.2f.6 Anchorage shall be inspected annually by a qualified person.

4.2f.7 Anchorage shall be recertified at least every 10 years by a registered engineer.

ROOF ANCHOR POINT INSTRUCTION MANUAL

Single Person Anchor (Recommended Set Back)

Set Back From Leading Edge: 12'-0"

Anchor Spacing: 20'-0" to 30'-0" o.c.

Working Angle From Anchor Centerline: 15° Max.

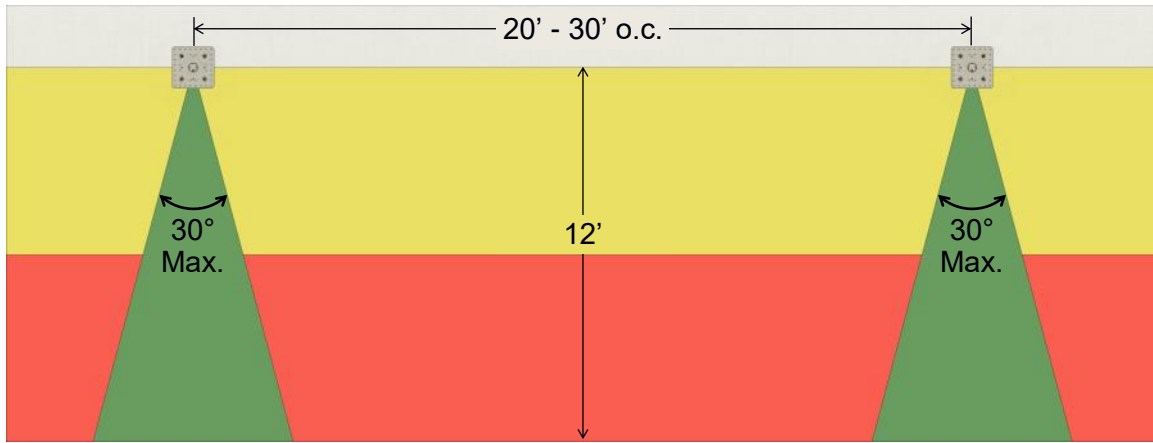
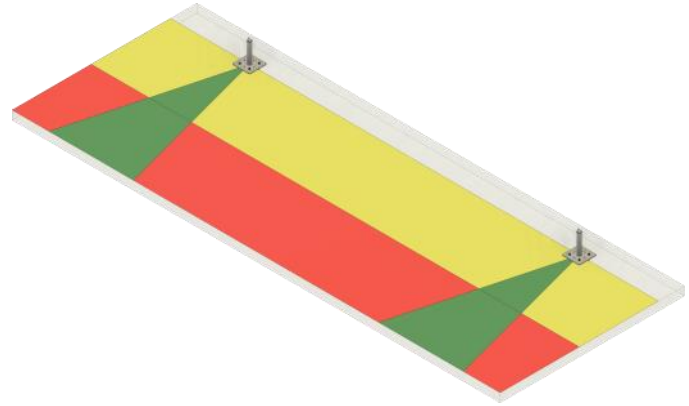

Single Person Anchor (Minimum Set Back)

Set Back From Leading Edge: 6'-0"

Anchor Spacing: 20'-0" to 30'-0" o.c.

Working Angle From Anchor Centerline: 15° Max.

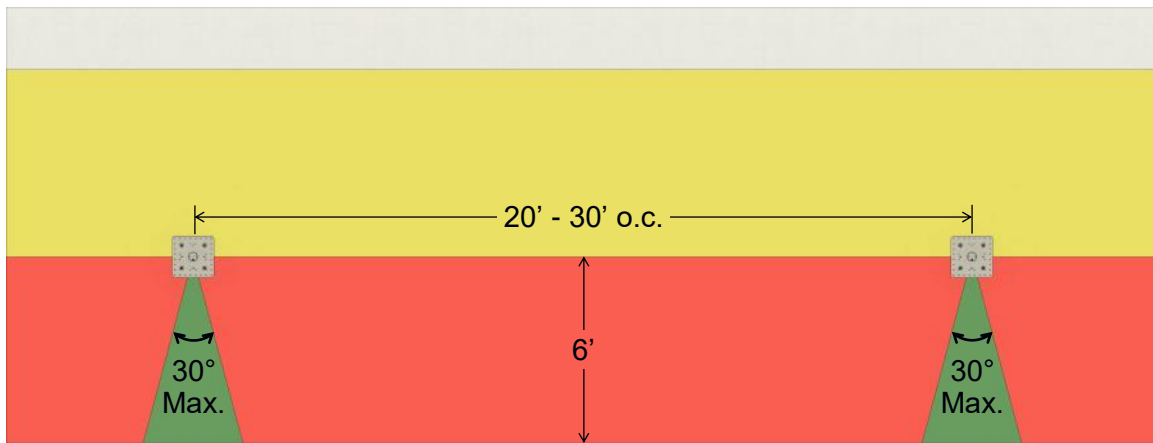
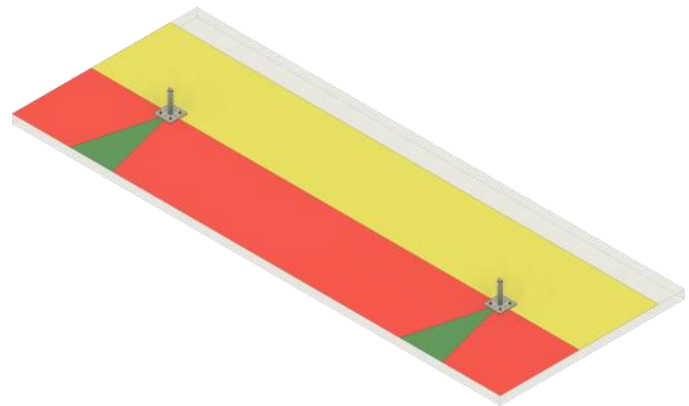

ROOF ANCHOR POINT INSTRUCTION MANUAL

E
N
G
L
I
S
H

Window Washing Anchors (Recommended Set Back)

Set Back From Leading Edge: 12'-0"

Suspension Anchor Spacing: 12'-0" o.c. Max.

Working Angle From Anchor Centerline: 15° Max.

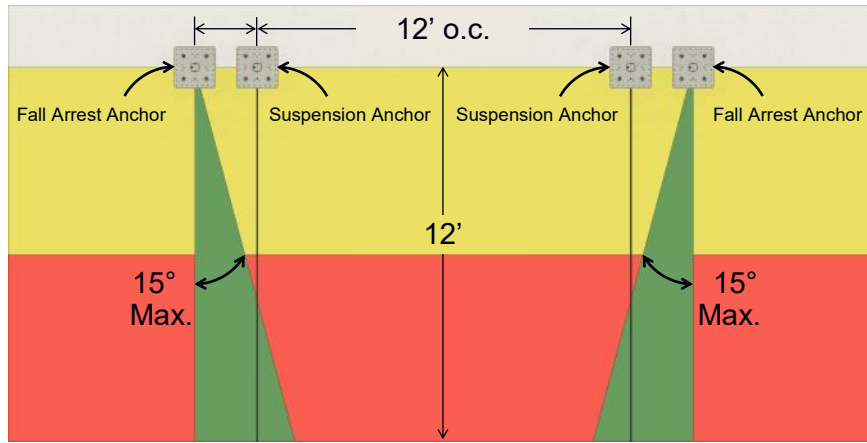
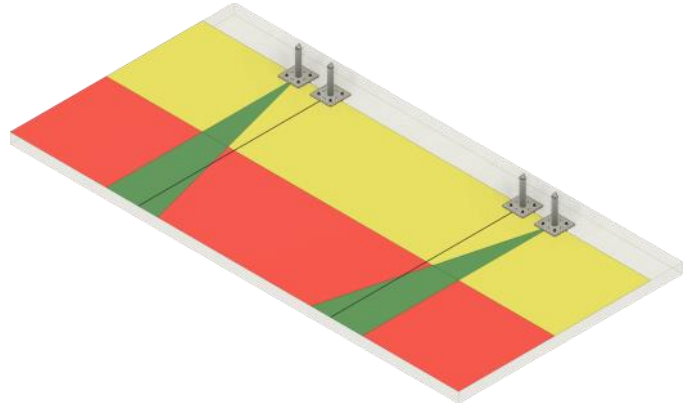

Window Washing Anchors (Alternative Set Backs)

Set Back From Leading Edge: 6'-0" to 12'-0"

Suspension Anchor Spacing: 12'-0" o.c. Max.

Working Angle From Anchor Centerline: 15° Max.

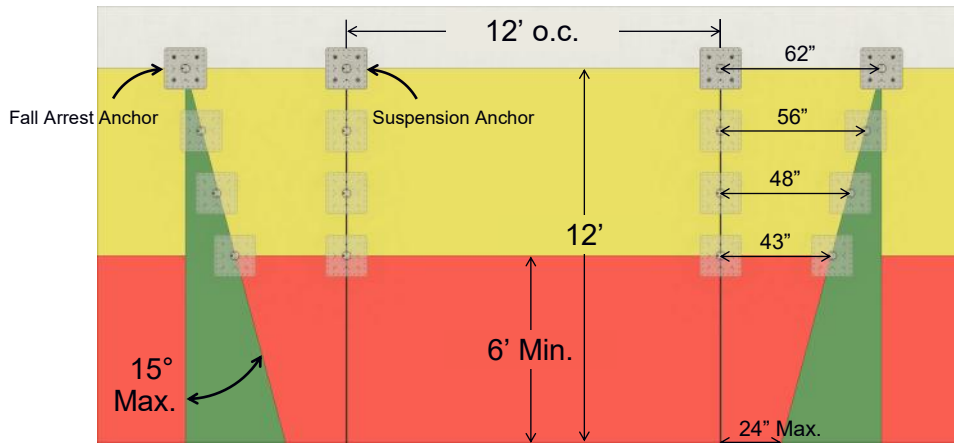
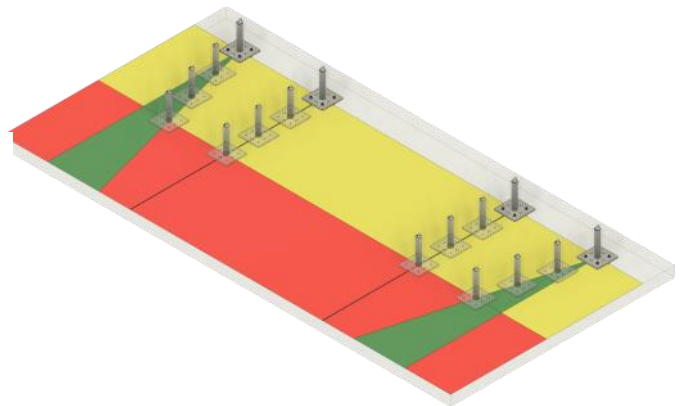

ROOF ANCHOR POINT INSTRUCTION MANUAL

5.0 Making Connections

- 5.1 Connectors must meet current ANSI, OSHA, CalOSHA, CSA or other Standards that may be applicable to the jurisdiction in which anchor points are installed.
- 5.2 Window washers may use knots approved by IWCA for suspension applications.
- 5.3 Only one connector shall be attached to an anchor point at any time.

6.0 Inspections, Maintenance and Care

- 6.1 Each anchor shall be visually inspected to ensure anchors are free from defects or damage caused by shipping and handling prior to installation.
- 6.2 Anchor points shall be inspected and certified by a qualified or competent person prior to use for fall protection or suspension.
- 6.3 Annual inspections of every anchor point shall be performed and documented. Below is a recommended list of inspection items:
 - 6.3a Visually inspect welds for cracks or other signs of failure. Immediately remove from service if cracks or other signs of failure are apparent per your companies lockout/tagout procedures.
 - 6.3b Visually inspect anchor points for rust. If rust is present, clean the affected area and apply cold zinc coating over affected areas.
 - 6.3c Verify Permanent Identification (PID) label is in place and legible. If the PID is missing or illegible, contact Leading Edge Safety for replacement label.
 - 6.3d Visually inspect the riser for bending or deformation. If the riser is deformed or bent, immediately remove from service per your companies lockout/tagout procedures.
 - 6.3e Visually inspect anchor points for any missing fasteners. If any required fasteners are missing, immediately remove from service per your companies lockout/tagout procedures.
 - 6.3f Ensure vent hole plug is in place. If the plug is missing, contact Leading Edge Safety for a replacement plug.
- 6.4 Anchors subjected to a free fall shall be removed from service until inspected by a qualified or competent person.

6.5 Simplified Inspection List:

INSPECTION ITEMS	✓ / ✗	IF CONDITION EXISTS OR PART IS MISSING
CHECK WELDS		REMOVE FROM SERVICE
CHECK FOR RUST		REPAIR
CHECK FOR PID LABEL		REPLACE
CHECK FOR DEFORMATION		REMOVE FROM SERVICE
CHECK FASTENERS		REMOVE FROM SERVICE
CHECK VENT PLUG		REPLACE

ROOF ANCHOR POINT INSTRUCTION MANUAL

7.0 IN THE EVENT OF A FALL

- 7.1 Call 911 and report the fall emergency immediately.
- 7.2 Follow your company policy and site-specific rescue plan.
- 7.3 Before attempting to rescue a fall victim connected to a Roof Anchor Point, ensure the Roof Anchor Point is secure & stable.
- 7.4 Rescuers should attach themselves in fall restraint to a secondary Roof Anchor Point not involved in the fall or other certified anchor point before attempting to rescue a fall victim. In the event a secondary Roof Anchor Point or other certified anchor point is not available, wait for emergency services to arrive.
- 7.5 Remove the Roof Anchor Point from service by appropriate lock out/tag out procedures until the Roof Anchor Point has been inspected and recertified by a qualified person.

ROOF ANCHOR POINT INSTRUCTION MANUAL

E
N
G
L
I
S
H



Copyright © 2022 by Leading Edge Safety, LLC
1345 Taney, North Kansas City, MO 64116
www.LeadingEdgeSafety.net

PRINTED IN THE UNITED STATES OF AMERICA