

LEADING EDGE SAFETY

INSTRUCTION MANUAL

STINGERTM PATENT # US 8240431 B2
Mobile Fall Protection System

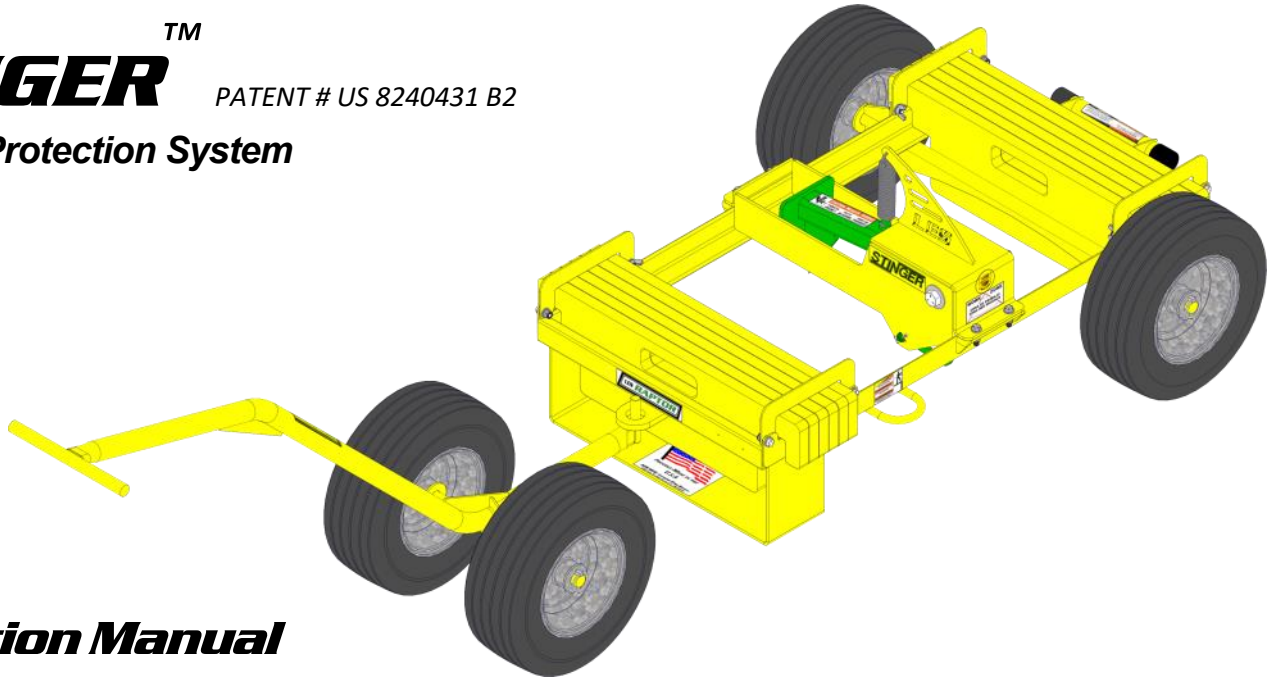

Instruction Manual

WARNING

Serious injury or death may result if this product is used for purposes other than designed. The manufacturer provides the following instructions for the use and care of this equipment. It is the responsibility of the purchaser to understand and convey explicit instruction to each user. The AES Manufacturing/Leading Edge Safety STINGER™ complies with the requirements of the Federal Occupational Safety and Health Administration (OSHA) when set up and used according to the manufacturers' instructions.

TABLE OF CONTENTS

INTRODUCTION

Standards and Requirements_____	3
Accessories_____	4
Parts List_____	5

GETTING STARTED

Applications_____	9
Definitions_____	9
Use & Limitations_____	10
Hoisting or Lifting_____	12
General Safety_____	12
Before Each Use_____	13
Positioning the Unit_____	13
Special Applications_____	15
Making Connections_____	16
Maintenance, Care & Storage_____	17
In The Event of A Fall_____	17

APPENDIX

Appendix A - Troubleshooting_____	18
Appendix B - Replacing Locking Plate on Engagement Box_____	19
Inspection & Maintenance Log_____	22

STINGER™ INSTRUCTION MANUAL

**E
N
G
L
I
S
H**

***LEADING EDGE SAFETY, LLC* Stinger™ Instruction Manual**

Published by Leading Edge Safety, LLC
North Kansas City, MO

STINGER COMPLETE MOBILE FALL PROTECTION SYSTEM

is a registered trademark of
Leading Edge Safety, LLC
1345 Taney
North Kansas City, MO 64116
www.LeadingEdgeSafety.net

Copyright © 2020 by Leading Edge Safety, LLC

PRINTED IN THE UNITED STATES OF AMERICA

STINGER™ INSTRUCTION MANUAL

1.0 Standards and Requirements

1.1 The STINGER™, manufactured by Leading Edge Safety LLC, is a dynamic anchor designed to dissipate the energy generated from a fall event into the surrounding substrate and arrest a fall. The STINGER™ is capable of supporting a Maximum Arresting Force (MAF) of 1,800lbs for up to (1) worker on approved substrates. Therefore, the STINGER™ is an acceptable component of a complete active fall arrest system and satisfies those requirements specified in: ANSI/ASSE Z359.6-2009 “Specifications and Design Requirements for Active Fall Protection Systems.”

1.2 Let it be noted that this mobile fall protection anchorage unit shall only be used as part of a complete active fall protection system. Therefore, the following criteria must be met to satisfy ANSI/ASSE Z359.6-2009:

- 1.2a** Use of full body harness(s) in compliance with Z359.1-2007 “Safety Requirements for Personal Fall Arrest Systems, subsystems, and Components”
- 1.2b** Use of Lanyard(s) In compliance with Z359.13-2009 “Personal Energy Absorbers and Energy Absorbing Lanyards”
- 1.2c** Use of Connection(s) In compliance with Z359.12-2009 “Connecting Components for Personal Fall Arrest Systems”
- 1.2d** Use of Manufacturer’s Recommendations; the STINGER™ shall not be installed/positioned/utilized in a manner that violates the literature, instructions, technical bulletins or any other documentation produced by Leading Edge Safety LLC.
- 1.2e** Calculations by an authorized user (qualified person) to verify that the substrate, edge distance, free fall distance, and the number of workers attached to cart satisfies those requirements of ANSI Z359.6.
- 1.2f** The use of component(s) used in combination with the STINGER™ that are not covered by ANSI/ASSE Z359 will not result in an acceptable Active Fall Protection System.

1.3 In addition to satisfying Z359.6, the STINGER™ is also in compliance with OSHA’s “Fall protection systems criteria and practices” (CFR › Title 29 › Subtitle B › Chapter XVII › Part 1926 › Subpart M › Section 1926.502). Section 1926.502(d)(15) requires that an anchor either support 5,000 pounds per employee attached or is used as part of a complete personal fall arrest system. Note that this anchorage unit is never intended to withstand a force of 5,000 lbs per user, but rather to be used as part of a complete personal fall arrest system. Determining if this complete personal fall arrest system can maintain a safety factor of at least (2) will require an authorized user to verify the above criteria.

STINGER SMC-000-16

MOBILE FALL PROTECTION SYSTEM

MODEL# SMC-000-16

- INCLUDES DOLLY
- 1-PERSON FALL ARREST
- 1-PERSON FALL RESTRAINT

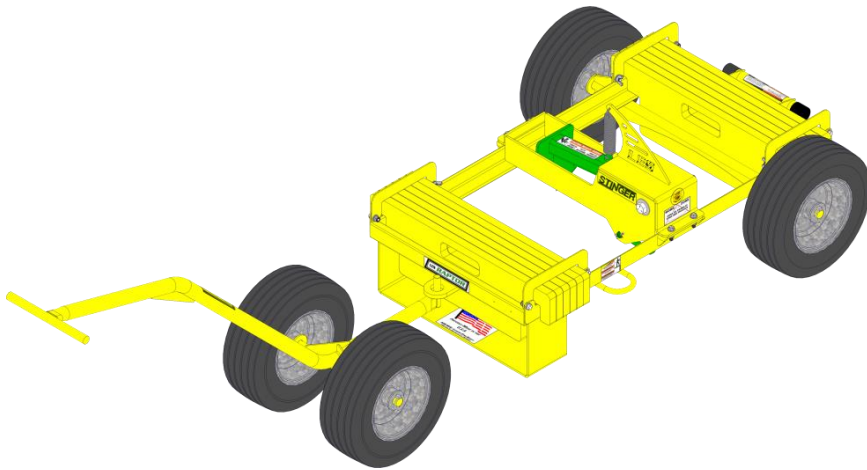

RAPTOR RESCUE

RMS-000-16

FALL RESCUE RETRIEVAL SYSTEM

MODEL# RMS-000-16

- 100 LF STAINLESS STEEL CABLE
- INCLUDES RETRIEVAL POLE

COMPATIBLE WITH ALL STINGER MODELS AND CONFIGURATIONS, TRIEX, R1000 AND R2000 MODELS.

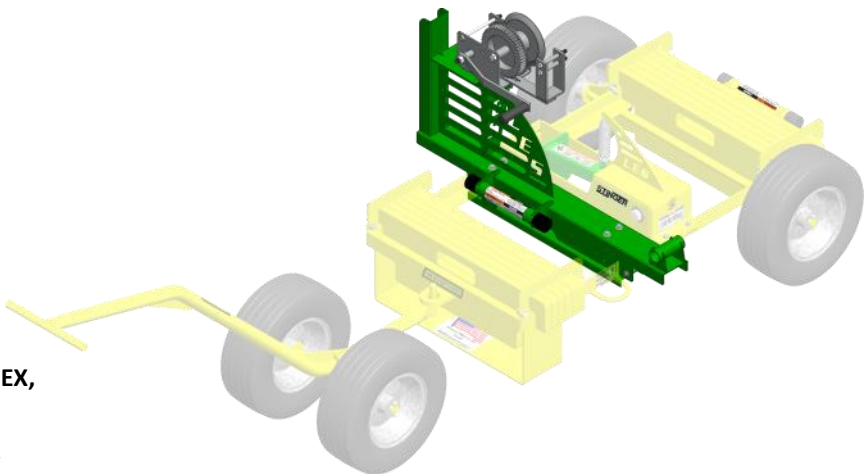

RAPTOR ALERT

RAS-000-18

FALL ARREST ALERT SYSTEM

MODEL# RAS-000-18

- 130 DB SIREN
- STROBE LIGHT
- 12v RECHARGEABLE BATTERY

COMPATIBLE WITH ALL STINGER MODELS AND CONFIGURATIONS, TRIEX, R1000 AND R2000 MODLES.

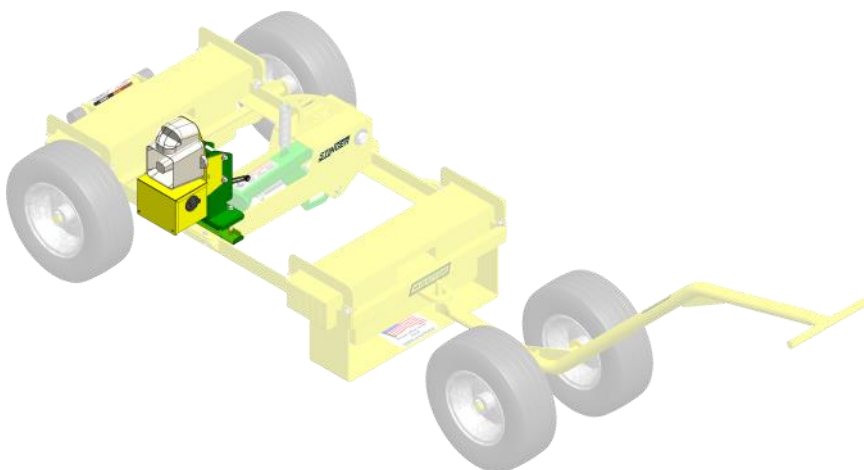

STINGER & DOLLY SERVICABLE PARTS

1	TRANSPORT DOLLY ASSEMBLY	SMD-000-11
2	STINGER FRAME ASSEMBLY	SMCF-000-11(16)
3	FLAT-FREE TIRE	T-16-6.5-8-SP
4	STINGER ENGAGEMENT BOX ASSEMBLY	SEBA-000-11
5	LES RAPTOR DECAL	LAB-001-15
6	MADE IN THE USA DECAL	LAB-014-15
7	WARNING - D-RING HOIST DECAL	LAB-APX-001-09
8	WARNING - WORK ZONE DECAL	LAB-GB-001-09
9	WARNING - PINCH POINT DECAL	LAB-IB-001-09
10	WARNING - INSTRUCTION DECAL	LAB-IB-002-09c
11	STINGER DECAL	LAB-SMC-001-11
12	3/16" X 1-1/4" LINCH PIN	LP-187-1312
13	STINGER 50# COUNTERWEIGHT	SMC-CW-050-1-11
14	COUNTERWEIGHT HOLD-DOWN CLIP	SMCF-008-11
15	1" FLAT WASHER	W-1-FLT-ZC

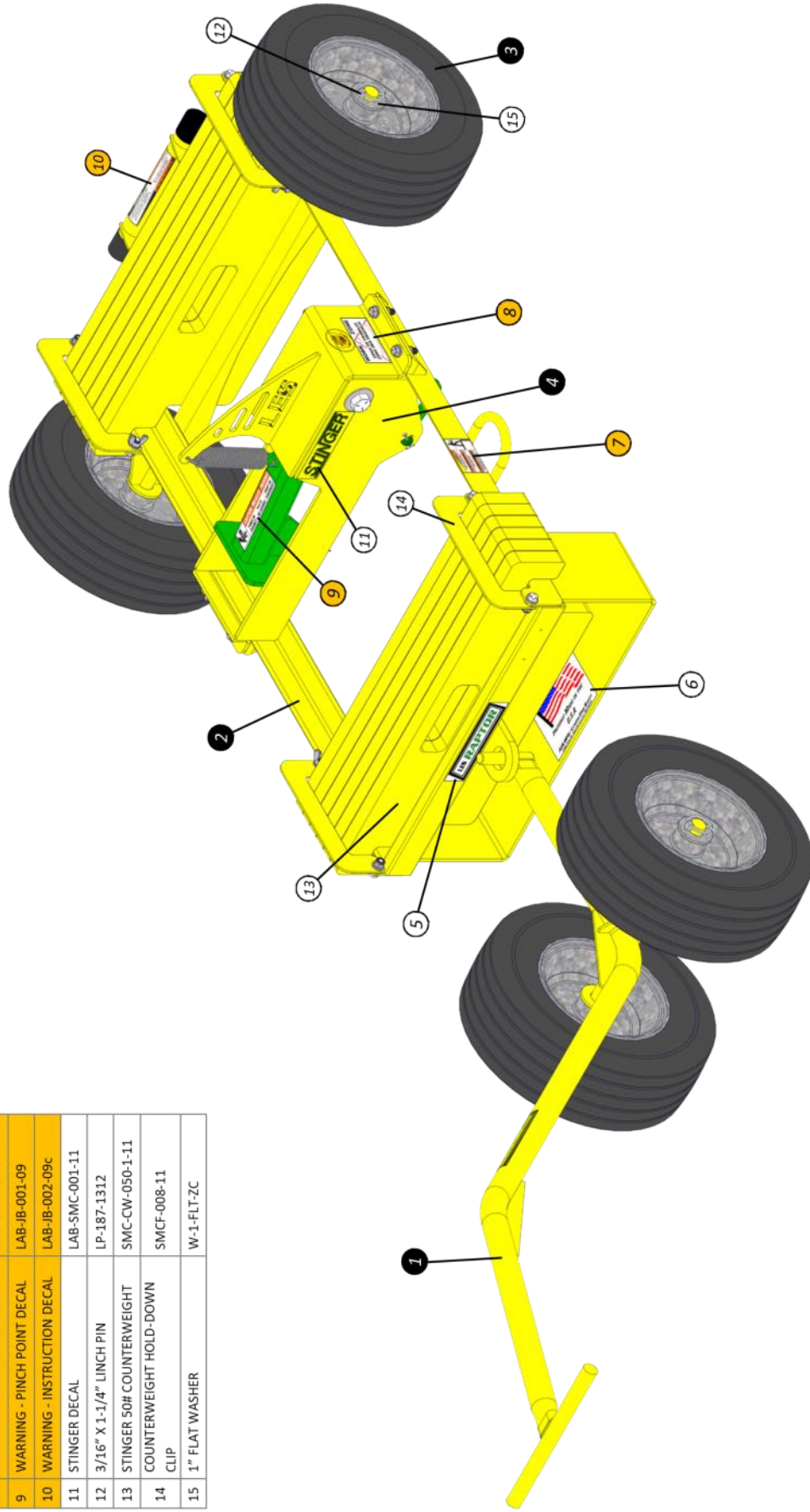

STINGER SERVICABLE PARTS

2	STINGER FRAME ASSEMBLY	SMCF-000-11(16)
3	FLAT-FREE TIRE	T-16-6.5-8-SP
4	STINGER ENGAGEMENT BOX ASSEMBLY	SEBA-000-11
5	LES RAPTOR DECAL	LAB-001-15
6	MADE IN THE USA DECAL	LAB-014-15
7	WARNING - D-RING HOIST DECAL	LAB-APX-001-09
8	WARNING - WORK ZONE DECAL	LAB-GB-001-09
9	WARNING - PINCH POINT DECAL	LAB-IB-001-09
10	WARNING - INSTRUCTION DECAL	LAB-IB-002-09c
11	STINGER DECAL	LAB-SMC-001-11
12	3/16" X 1-1/4" LINCH PIN	LP-187-1312
13	STINGER 50# COUNTERWEIGHT	SMC-CW-050-1-11
14	COUNTERWEIGHT HOLD-DOWN CLIP	SMCF-008-11
15	1" FLAT WASHER	W-1-FLT-ZC

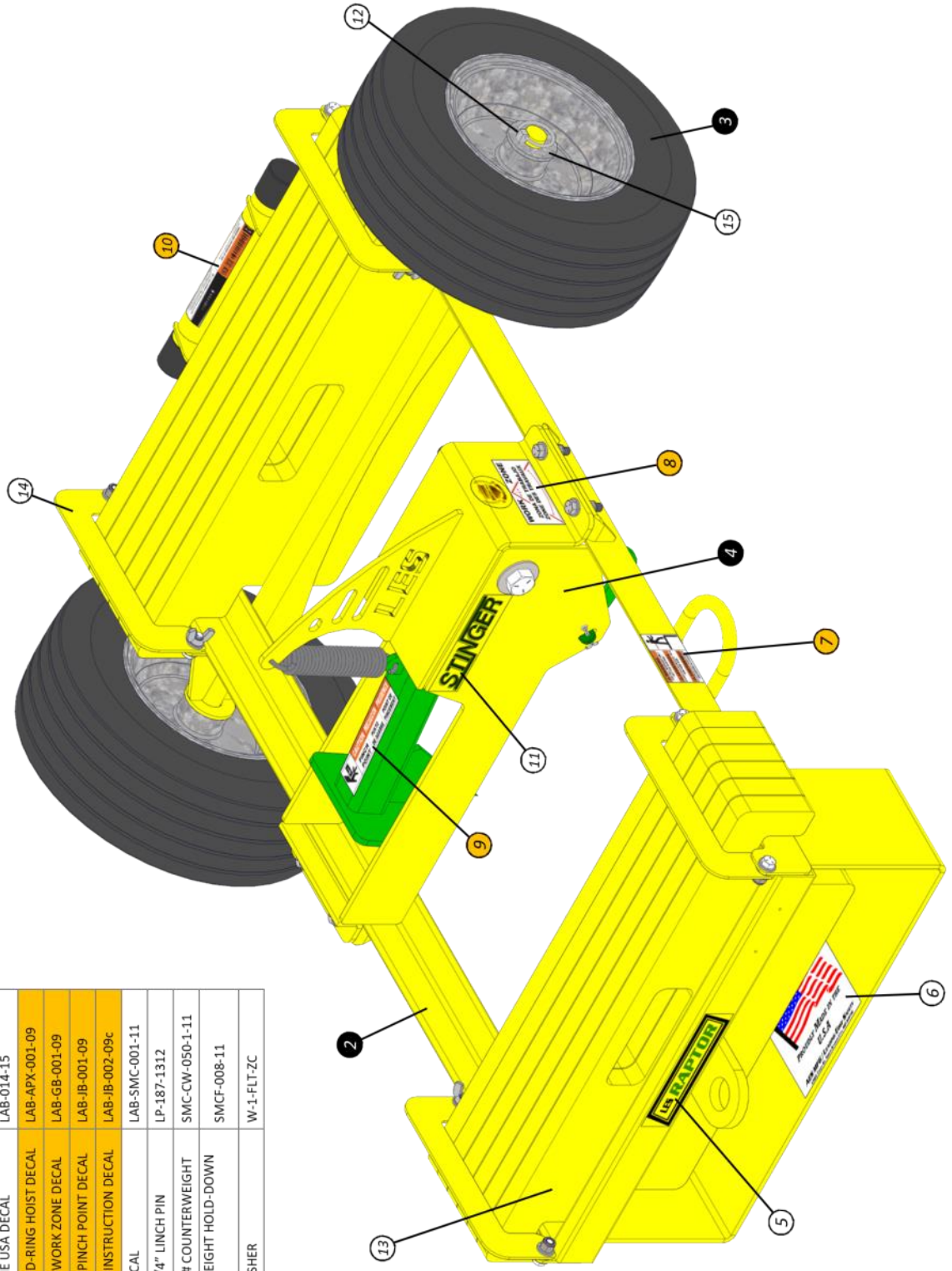

STINGER SERVICABLE PARTS

2	STINGER FRAME ASSEMBLY	SMCF-000-11(16)
3	FLAT-FREE TIRE	T-16-6.5-8-SP
4	STINGER ENGAGEMENT BOX ASSEMBLY	SEBA-000-11
7	WARNING - D-RING HOIST DECAL	LAB-APX-001-09
8	WARNING - WORK ZONE DECAL	LAB-GB-001-09
9	WARNING - PINCH POINT DECAL	LAB-JB-001-09
10	WARNING - INSTRUCTION DECAL	LAB-JB-002-09c
11	STINGER DECAL	LAB-SMC-001-11
12	3/16" X 1-1/4" LINCH PIN	LP-187-1312
13	STINGER 50# COUNTERWEIGHT	SMC-CW-050-1-11
14	COUNTERWEIGHT HOLD-DOWN CLIP	SMCF-008-11
15	1" FLAT WASHER	W-1-FLT-ZC
16	SERIAL NUMBER PLATE	LE-SMC-SP

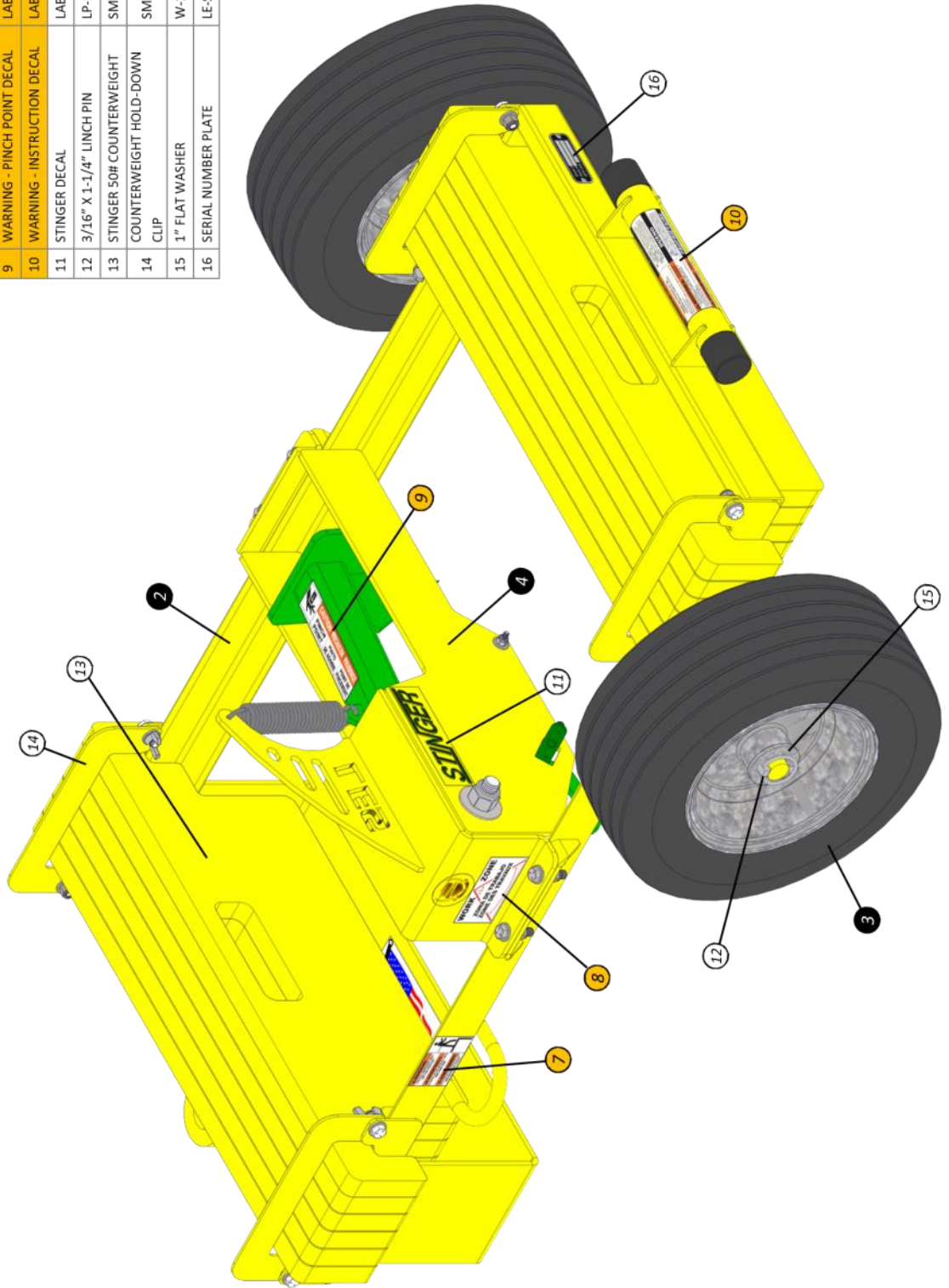

STINGER ENGAGEMENT BOX SERVICABLE PARTS

4	STINGER ENGAGEMENT BOX ASSEMBLY	SEBA-000-11
9	WARNING - PINCH POINT DECAL	LAB-JB-001-09
17	STINGER ENGAGEMENT ARM SPRING ***NON-SERVICABLE PART	SES-001-11
18	LOCKING PLATE FOR ENGAGEMENT BOX	SPMB-005-11
19	LOCKING PLATE SPRING	LES-001-11

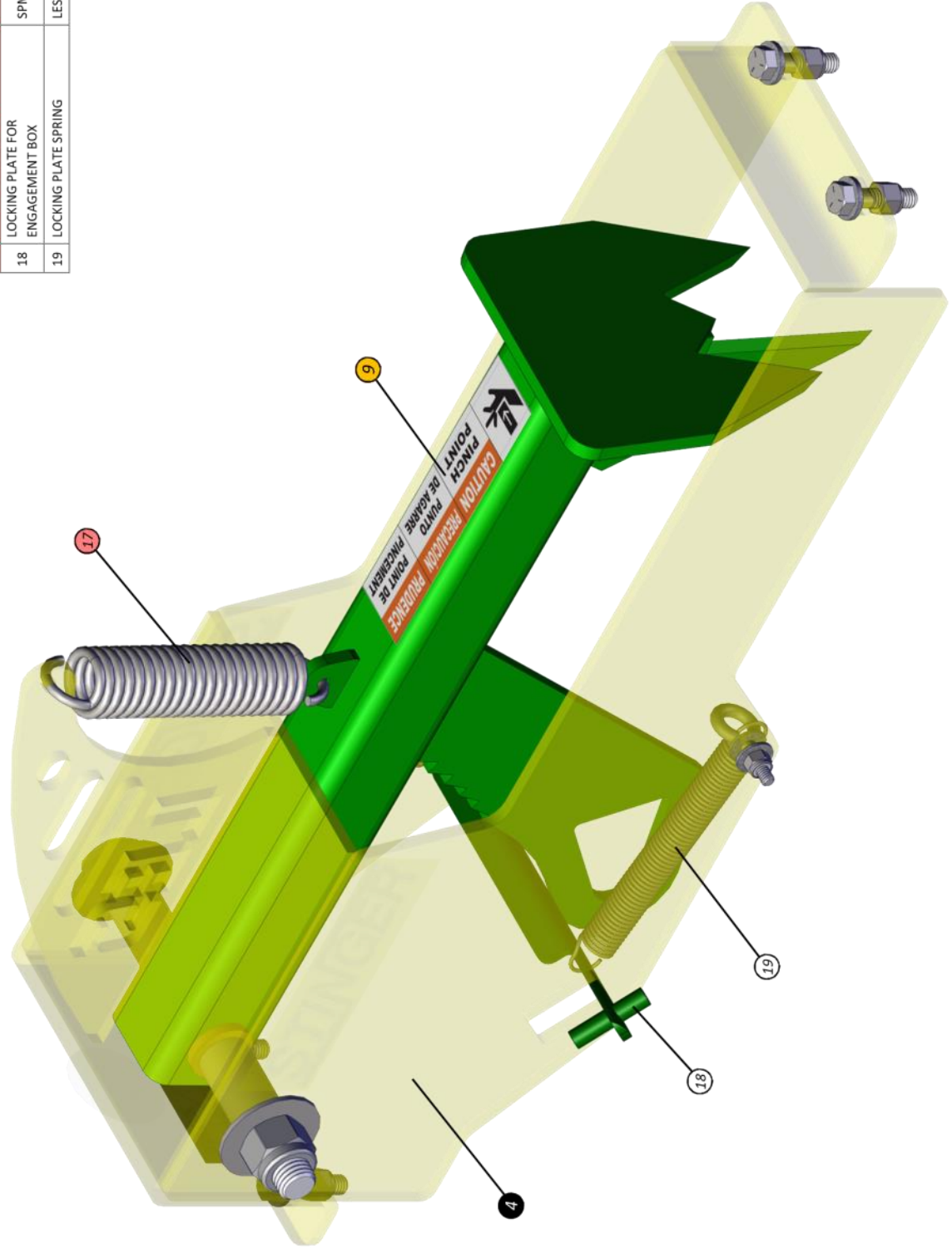

STINGER™ INSTRUCTION MANUAL

2.0 APPLICATIONS

- 2.1 The STINGER™ is designed to be used as an anchorage as part of a complete mobile fall protection system. The STINGER™ may be used where worker mobility and fall protection are required. See WWW.OSHA.GOV for all regulations and standards.
- 2.2 The STINGER™ allows for up to one worker to be tied-off for fall arrest to the *Fall Arrest Attachment Point* and an additional one worker tied-off simultaneously for fall restraint to the *Fall Restraint D-Ring*. FIG 2-2
See the following definitions (Section 3.0):

FIG 2-2

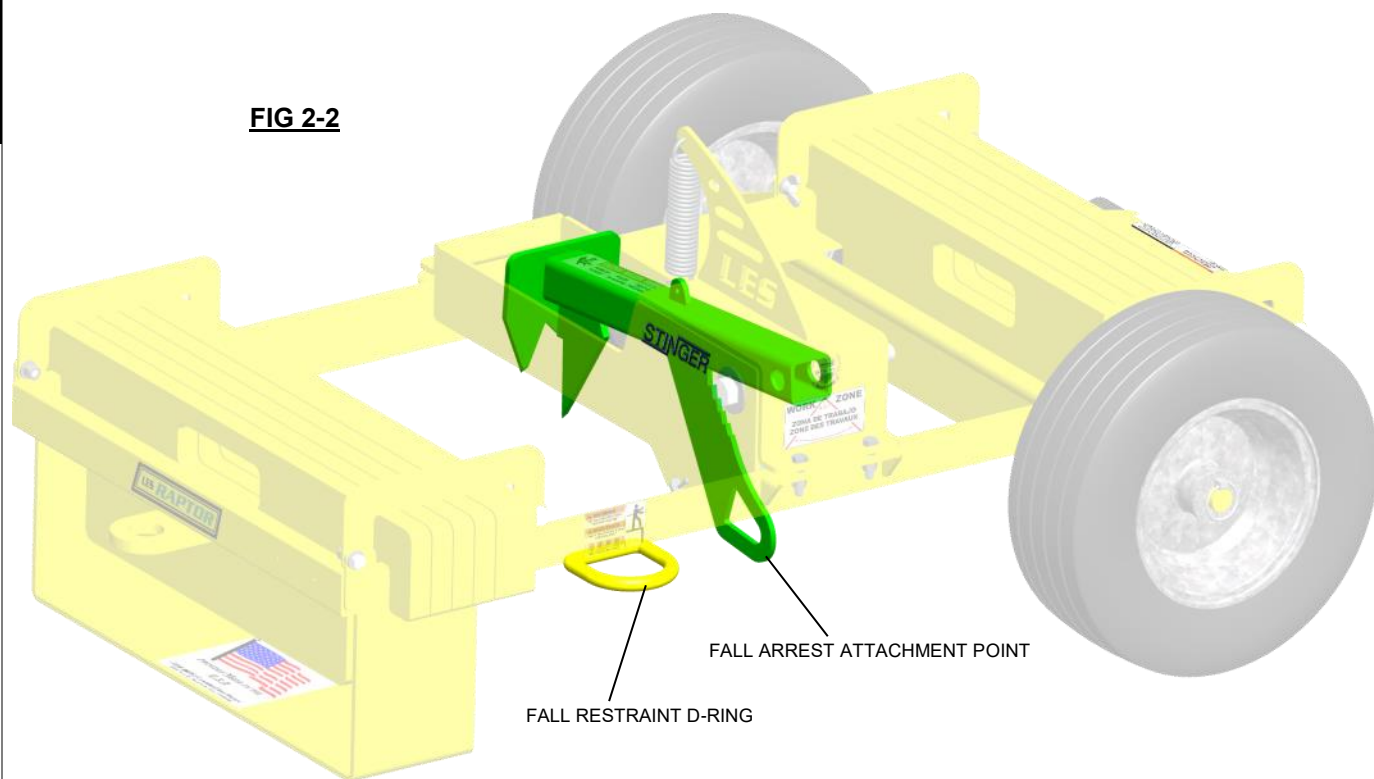

3.0 DEFINITIONS:

- 3.1 **Fall Restraint System** – A fall restraint system (FRS) *prevents* the user from falling. The system is comprised of a body harness along with an anchorage, connectors and other necessary equipment. The components typically include a lanyard and also may include a lifeline and other devices. The STINGER™ can be used as an anchorage in a fall restraint system for up to one worker.
- 3.2 **Personal Fall Arrest System** – A personal fall arrest system (PFAS) arrests a fall *after* a fall has begun. The system is comprised of an anchorage, connectors, and a body harness and may include a deceleration lifeline, or suitable combinations. Note that a PFAS does NOT prevent a fall from occurring. The STINGER™ can be used as an anchorage in a PFAS for up to one worker. A Personal Fall Arrest System must meet the following OSHA requirements:
 - Limit maximum arresting force on an employee to 1,800 pounds when used with a body harness;
 - Be rigged so that an employee can neither free-fall more than 6 feet (1.8 meters) nor contact any lower level;
 - Bring an employee to a complete stop and limit maximum deceleration distance an employee travels to 3.5 feet (1.07 meters); and
 - Have sufficient strength to withstand twice the potential impact energy of an employee free-falling a distance of 6 feet (1.8 meters) or the free-fall distance permitted by the system, whichever is less.
- 3.3 **Anchorage** — An anchorage is a secure point of attachment for lifelines, lanyards, or deceleration devices. The STINGER can be used as an anchorage.

STINGER™ INSTRUCTION MANUAL

4.0 USE AND LIMITATIONS

4.1 LOAD REQUIREMENTS—Before the STINGER is hoisted to any roof surface, the user must verify that the deck assembly can accommodate the live load requirements of the STINGER.

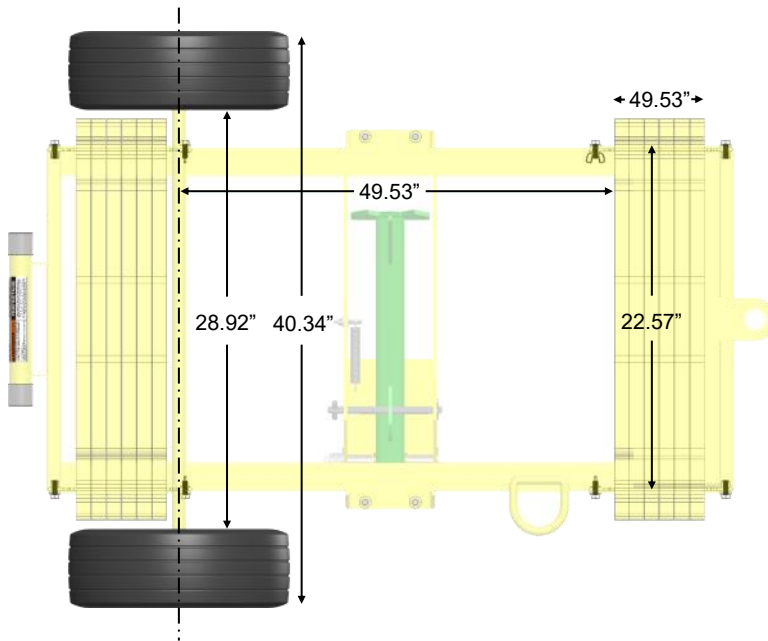

Approximate Unit Weight: 743 lbs
 Tire Footprint: 2.5" x 4.75"
 Approximate Weight per Tire: 185.75 lbs
 Approximate Pounds per SqIn: 15.64 psi
 Plate Footprint: 6" x 22.5"
 Approximate Plate Pressure: 371.5 lbs
 Approximate Pounds per SqIn: 2.75 psi

FIG 4-0

4.2 APPROVED SUBSTRATES:

BUILT-UP ROOFING (BUR) ²	MODIFIED BITUMEN ²
THERMOPLASTIC POLYOLEFIN (TPO) ²	ETHYLENE PROPYLENE DIENE MONOMER (EPDM) ²
POLYVINYL CHLORIDE (PVC) ²	BALLASTED SINGLE-PLY MEMBRANES ²
BUILT-UP ROOFING (BUR) AND GRAVEL ²	INVERTED ROOF MEMBRANE ASSEMBLY (IRMA) ²
ROOF COATINGS ²	
PLYWOOD	HIGH DENSITY FIBERBOARD ^{1,4}
DENSDECK® ^{1,4}	GYPSUM BOARD ^{1,4}
POLYISOCYANURATE (ISO) ^{1,4}	EXPANDED POLYSTYRENE (EPS) ^{1,4}
EXTRUDED POLYSTYRENE (XPS) ^{1,4}	SPRAY-APPLIED POLYURETHANE ^{1,4}
INSULATING LIGHTWEIGHT CONCRETE	
METAL DECK (22GA AND 20GA)	METAL DECK (18GA ⁴)
STRUCTURAL LIGHTWEIGHT CONCRETE	CONCRETE DECK (4000-9000psi)
TOPSOIL—COMPACTED	GYPSUM DECK
ASPHALT PAVEMENT	GRAVEL—COMPACTED
PANELIZED SLAB FORMWORK ⁵	

FLAT SURFACES AND UP TO 2:12 SLOPE.

DO NOT USE THE STINGER™ ON THE FOLLOWING SUBSTRATES:

- ICE
- SNOW
- TECTUM DECK⁵
- METAL DECKS LESS THAN 22GA⁵ OR GREATER THAN 18GA⁵

1 WHEN MECHANICALLY FASTENED OR ADHERED TO AN APPROVED SUBSTRATE.
 2 WHEN USED AS PART OF A COMPLETE ROOF ASSEMBLY.
 3 SUBSTRATE IS ALLOWABLE WHEN COVERED WITH 3/4" PLYWOOD SECURED WITH A MINIMUM OF EIGHT (8) FASTENERS. FIG 4-2
 4 SUBSTRATE IS ALLOWABLE WHEN TOTAL INSULATION THICKNESS IS GREATER THAN 3.875" OR USED WITH AN APPROVED METAL DECK. FIG 4-1
 5 FALL RESTRAINT ONLY—MAXIMUM 1 USER
 DensDeck® is a registered trademark of Georgia-Pacific Gypsum, LLC.

STINGER™ INSTRUCTION MANUAL

E
N
G
L
I
S
H

FIG 4-1

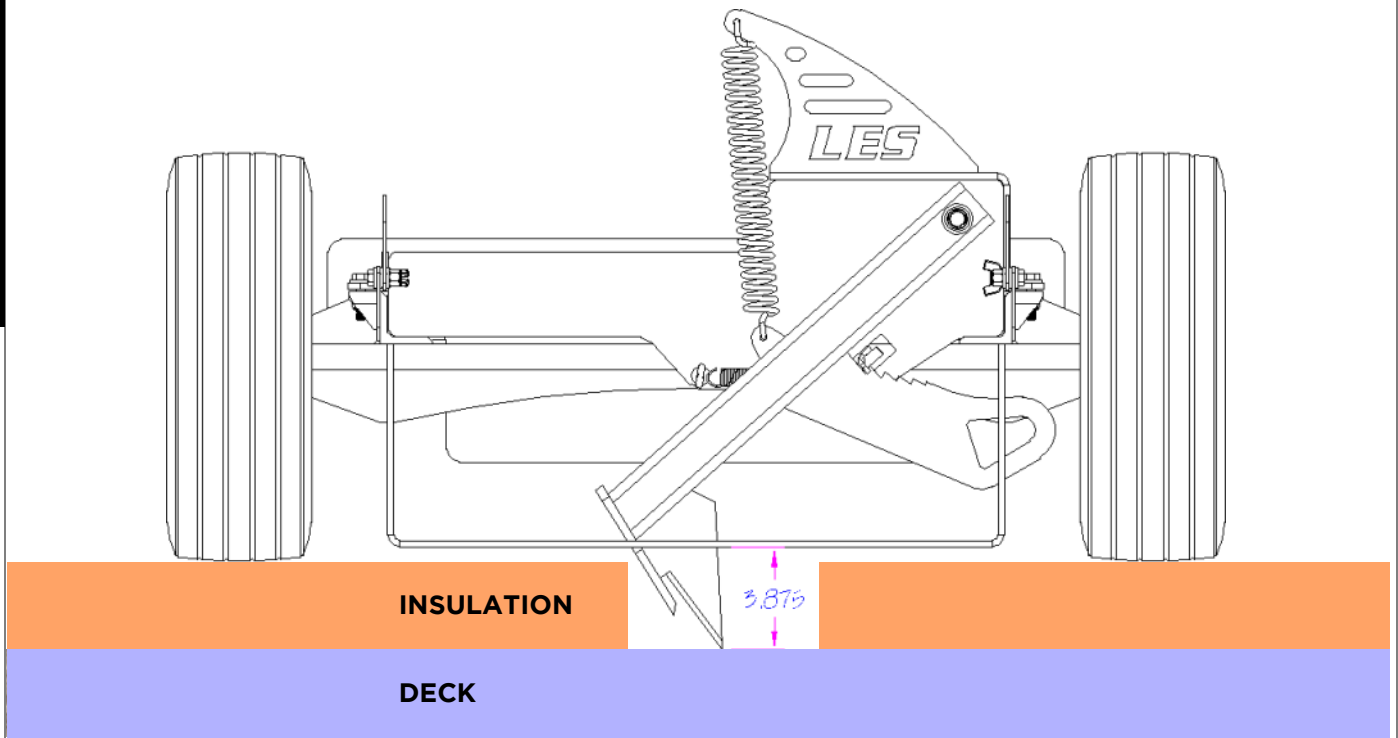
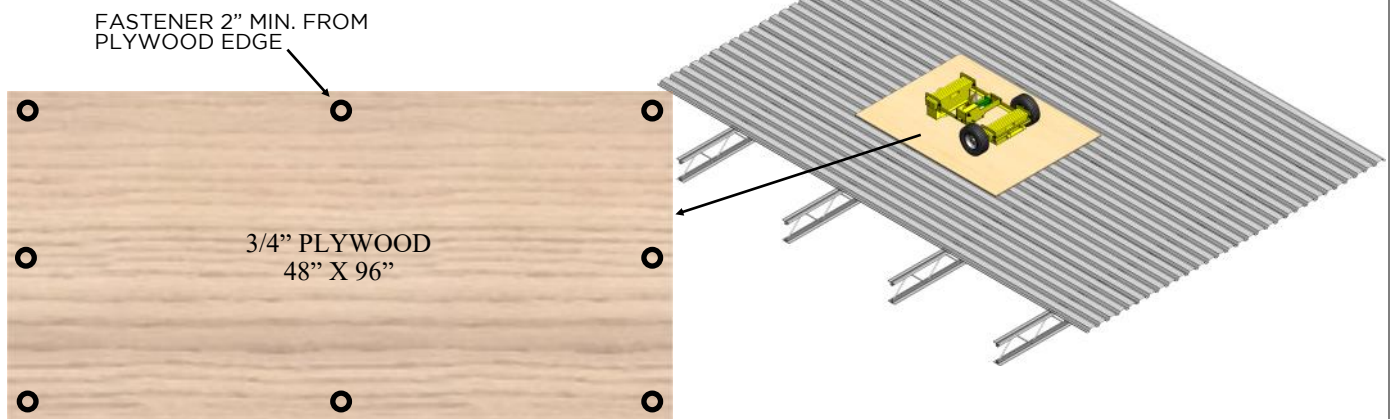

FIG 4-2



4.3 CAPACITY: The STINGER™ Mobile Fall Protection System is designed for a maximum of one person for fall arrest and one for fall restraint with a combined weight (clothing, tools) of no more than 310 lbs. per person. No more than two persons may be connected to the STINGER™ at any time.

IMPORTANT: DO NOT begin work for which fall protection is required until the STINGER™ unit and corresponding Fall Restraint System (FRS) or Personal Fall Arrest Systems (PFAS) have been completely installed. Do NOT disable any part of the FRS or PFAS, including the STINGER™ unit, or reposition the STINGER™ unit, until work for which fall protection is required has ceased.

STINGER™ INSTRUCTION MANUAL

5.0 HOISTING OR LIFTING

- 5.1 Loads may slip or fall if the STINGER is not hoisted or lifted properly and may result in injury or death.
- 5.2 Remove all Counterweights from the unit before hoisting or lifting.
- 5.3 Never hoist or lift the STINGER if the *Hoisting Ring* is damaged. FIG 5-3
- 5.4 Never hoist or lift the STINGER with unsecured materials on the unit.
- 5.5 Ensure any auxiliary equipment is properly and securely attached to the STINGER before hoisting or lifting.
- 5.6 The STINGER shall be hoisted or lifted following good industry practices, State and Federal Regulations, and hoisting and lifting equipment manufacturer's guidelines.
- 5.7 The STINGER was designed be to hoisted by a crane and is equipped with a hoisting ring.

FIG 5-3

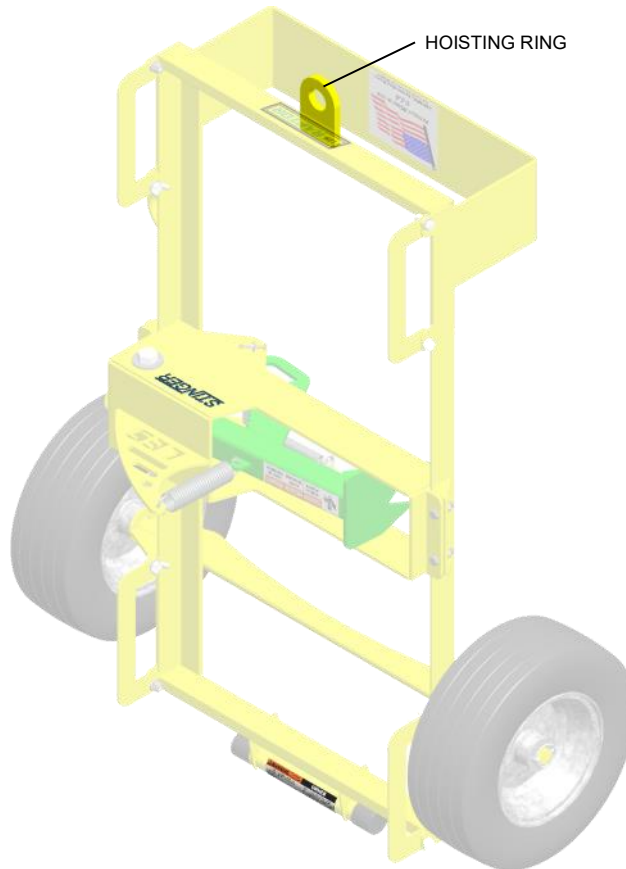

6.0 GENERAL SAFETY

- 6.1 **USE COMMON SENSE!** Most accidents can be avoided by using common sense and focusing on the job at hand.
- 6.2 The STINGER should not be used by persons whose ability or alertness is impaired by fatigue, intoxication, prescription or illegal drugs, or any other physical or mental cause that may expose the user or others to injury.
- 6.3 Always wear proper Personal Protective Equipment.
- 6.4 Keep hands and feet clear of moving parts including the Engagement Arm.
- 6.5 Do not use the equipment near electrical lines.
- 6.6 Do not allow passengers to ride on the safety cart.
- 6.7 Do not use on wet, slippery or icy substrates.

STINGER™ INSTRUCTION MANUAL

ENGLISH

6.0 GENERAL SAFETY (Continued)

- 6.8 Only use the STINGER on substrates and assemblies for which it has been tested. (Reference Sect 4.2 Approved Substrates)
- 6.10 Always uses caution and common sense when moving the unit. Additional workers may be needed to safely move the unit when additional materials, tools or equipment have been added to the unit.

7.0 BEFORE EACH USE

7.1 Before using this unit, a rescue plan and procedure in accordance with OSHA Standards must be in place to ensure prompt rescue in the event of a fall.

7.2 Inspect the unit for any damage. A maintenance log has been provided in this manual that may be copied and used to track inspections and damage.

7.2.A Check for loose, bent or damage parts, including the *Talon* and *Rake* tips of the *Engagement Arm*. FIG 7-2

7.2.B Check welded connections for visible distortion, cracks or other damage.

7.2.C Check Tie-off Ring for distortion or damage.

7.2.D Ensure all safety labels are present and fully legible. (Reference parts list pages 5-8)

7.2.E Check for corrosion on entire unit.

7.2.F Check *Engagement Arm* for freedom of movement.

7.2.G Check Attachment Point for freedom of movement.

7.2.H Ensure the Engagement Plate for Engagement Box is in the proper position.

7.2.I **DO NOT USE DAMAGED EQUIPMENT OR EQUIPMENT THAT HAS BEEN MODIFIED.**

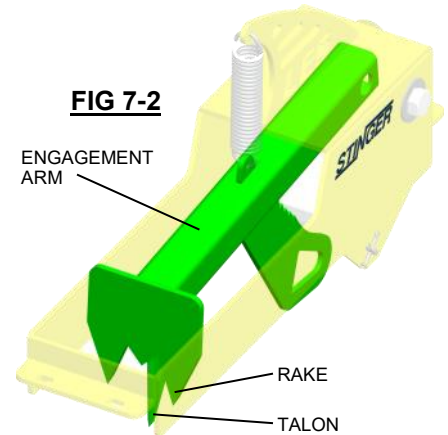

8.0 POSITIONING THE UNIT

8.1 Verify that the substrate the unit is to be used on is acceptable (Reference Sect 4.2 Approved Substrates) and the entire working surface has the strength and structural integrity to safely support both the workers and the unit.

8.2 Position the unit with the Fall Arrest Attachment Point side 12' - 15' away and parallel to the working edge to maximize the work zone. FIG 8-2a

The unit may be used a minimum of 4' from the leading edge, maintaining a maximum work zone of 45° or 2' from the center of the attachment point. FIG 8-2b

The unit may be used a maximum of 30' from the leading edge, however the work zone may not exceed 15' from the center of the attachment point. FIG 8-2b

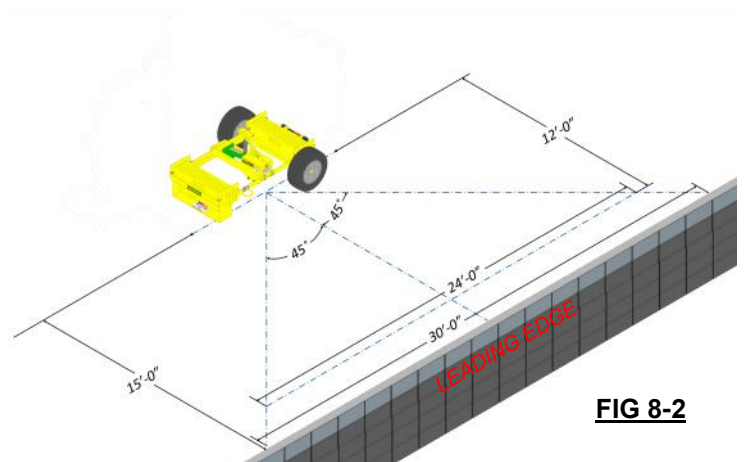

8.0 POSITIONING THE UNIT (Continued)

FIG 8-2b

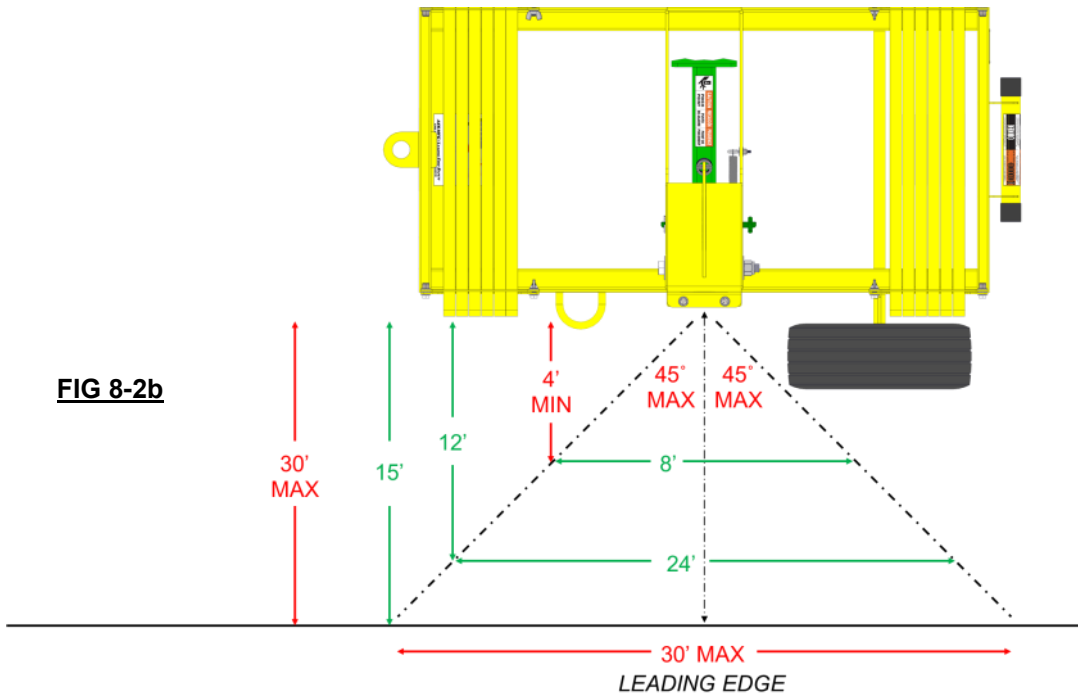

8.3 Once the unit is properly positioned, remove the Transport Dolly from the Stinger unit to begin use. FIG 8-3

FIG 8-3

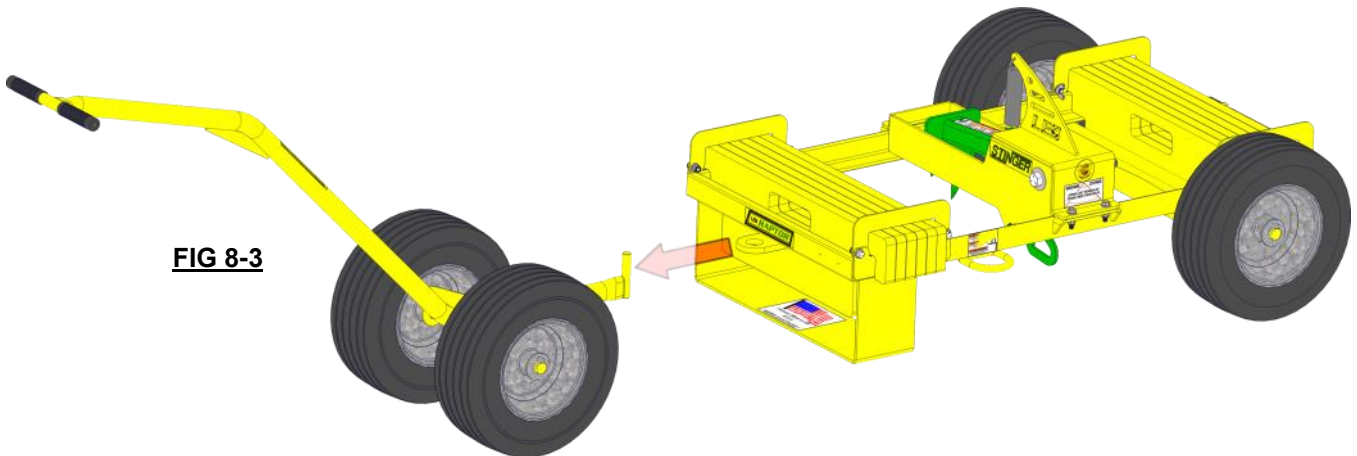

STINGER™ INSTRUCTION MANUAL

E
N
G
L
I
S
H

9.0 SPECIAL APPLICATIONS

9.1 DISSIMILAR HEIGHT WALKING/WORKING SURFACES

- 9.1.A The STINGER may be used for fall arrest and fall restraint in dissimilar height applications where worker is located on a surface lower than the surface the STINGER is positioned on and when properly set up and used with an SRL ANSI approved for leading edge conditions. FIG 9-1

FIG 9-1

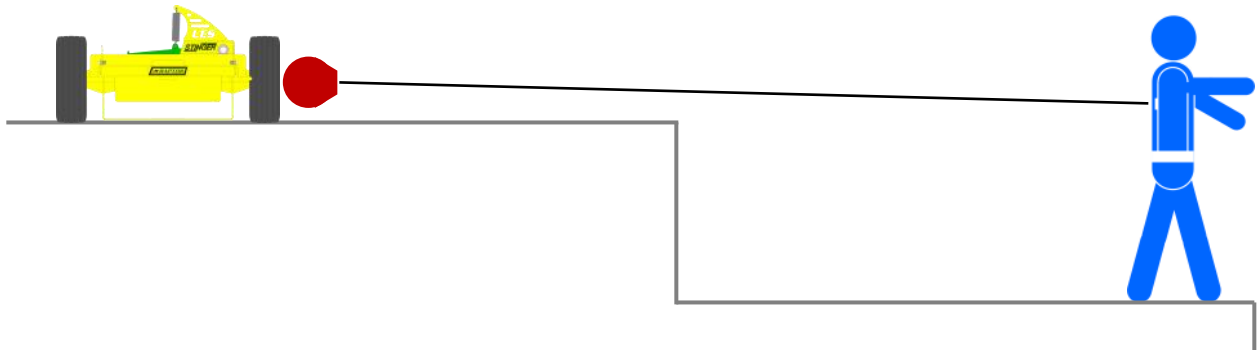

9.2 USE AT PARAPET WALLS

- 9.2.A The STINGER may be used at parapet walls up to 42" in height when properly set up 12' - 15' from the leading edge and used with an SRL ANSI approved for leading edge conditions. FIG. 9.2
- 9.2.B The STINGER may be used at parapet walls in excess of 42" in height when the SRL cable angle is 15 degrees or less. The distance between the STINGER and the leading edge may be increased beyond 15' to reduce the angle of the cable to 15 degrees or less. However, the leading edge work zone shall never exceed 30' in width. FIG 9-2

For parapet walls up to 45", Distance (B) = 15' (180")

For parapet walls over 45", use the formula below:

Parapet wall (A) / .25 = Distance (B)

Example: (A) 48" / .25 = (B) 192" or 16'

FIG 9-2

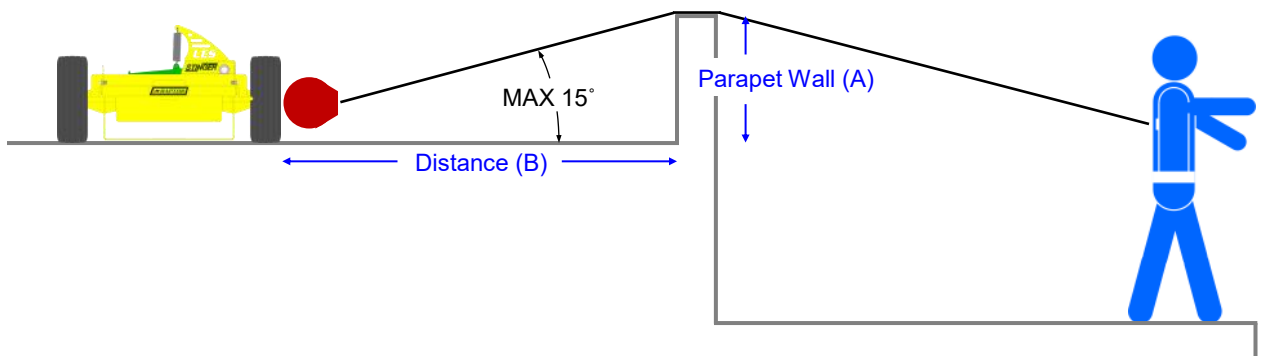

10.0 MAKING CONNECTIONS

- 10.1 Only connect to *Fall Arrest Attachment Point* for use as fall arrest. Only connect to *Fall Restraint D-Ring* for use as fall restraint.
- 10.2 SRL's and lifelines shall only be connected to the *Fall Arrest Attachment Point* or to *Fall Restraint D-Ring*.
FIG 10-2

FIG 10-2

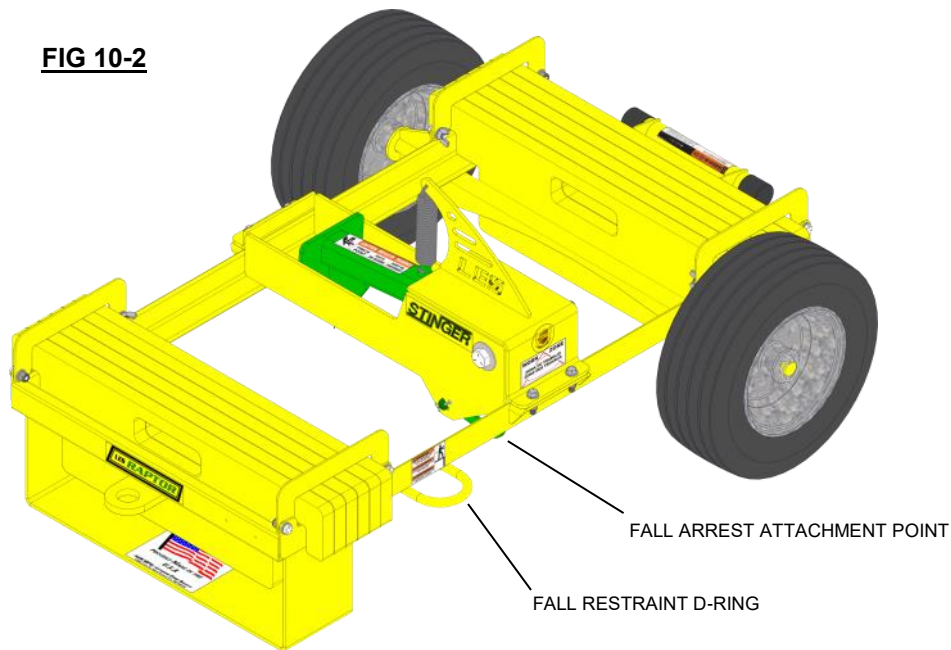

- 10.3 Only use self-locking snap hooks and self-locking carabiners when connecting SRL and lifelines to the STINGER. Only use connectors that are suitable to each application. Ensure connections are compatible in size, shape and strength. Do not use equipment that is not compatible with the STINGER connection points.
- 10.4 Ensure that all connections are fully closed, locked and secure prior to use.
- 10.5 When connecting to the *Fall Restraint D-Ring*, ensure that the fall restraint system, including lanyards, lifelines, harnesses, etc., do not allow the user to travel close enough to a leading edge to experience a fall.

STINGER™ INSTRUCTION MANUAL

11.0 MAINTENANCE, CARE & STORAGE

- 11.1 If the *Engagement Arm* has been activated by a fall, the *Stinger Engagement Box Assembly* must be replaced before using the unit in fall arrest. Refer to assembly drawings for the location and part number and [Appendix C for replacement instructions](#).
- 11.2 Keep tires free from build up and debris. Asphalt or adhesive build up on the tires can cause the unit to function improperly.
- 11.3 Inspect all bolts, pins, springs, welds and paint for visible damage. Damaged or missing parts can prevent the STINGER from working properly.
- 11.4 Maintain the paint finish to prevent corrosion. Use rust inhibitive paint compatible with the powder coat finish.
- 11.5 Store the STINGER in a place protected from the weather. *Vinyl Weather Covers* are available for long-term outdoor storage. Contact your local distributor or Leading Edge Safety for pricing and availability.
- 11.6 Rotate the tires or block the axle to avoid flat spots on the tires during long-term storage.

12.0 IN THE EVENT OF A FALL

- 12.1 Call 911 and report the fall emergency immediately.
- 12.2 Follow your company policy and site-specific rescue plan.
- 12.2 Before attempting to rescue a fall victim connected to the STINGER, ensure the STINGER is stable with the claw engaged into the substrate and/or both tires and front plate are contacting the walking/working surface.
- 12.3 Rescuers should attach themselves in fall restraint to a secondary STINGER not involved in the fall or other certified anchor point before attempting to rescue a fall victim. In the event a secondary STINGER or certified anchor point is not available, rescuers may use the STINGER involved in the fall for fall restraint only.
- 12.4 If your STINGER is equipped with the *Raptor Rescue Retrieval System*, the fall victim should be lowered to the ground to await emergency services. In the event the fall victim cannot be lowered to the ground, they may be raised to the roof to await emergency services. Refer to the Raptor Rescue manual for complete instructions on its use.
- 12.5 Once a fall victim has been recovered, the STINGER may be disengaged from the substrate. Use caution when disengaging the unit, keep hands and feet clear of moving parts and pinch points. In some cases, the *Engagement Arm* may become wedged into the substrate. Disengage the *Locking Plate* by pulling up on the *Locking Plate t-handle*. Use a wooden or metal beam to apply leverage against the underside of the *Engagement Arm* to disengage the rake and/or talon from the substrate.
- 12.6 Remove the unit from fall arrest service by appropriate lock out/tag out procedures *Stinger Engagement Box Assembly* has been replaced.
- 12.7 If no damage has occurred to the unit as a result of the fall, the unit may be used in fall restraint only until the *Stinger Engagement Box Assembly* has been replaced.

APPENDIX A—TROUBLESHOOTING

If any of the following issues are the result of a user falling while connected to the STINGER, the Stinger Engagement Box Assembly must be replaced before returning the unit to service.

PROBLEM

Engagement Arm (4a) assembly is resting on the ground (not engaged in the substrate). (FIG A-1)

POSSIBLE CAUSE

Locking Plate (18) is engaged and holding the Engagement Arm (4a) down.

SOLUTION

Press down on the Engagement Arm (4a) and lift up on the Locking Plate (18) to allow the Engagement Arm (7) to return to its resting position. If the Engagement Arm (4a) does not move upward to its resting position, see next step.

POSSIBLE CAUSE

Locking Plate (18) is bent or damaged.

SOLUTION

Replace the Locking Plate (18).

FIG A-1

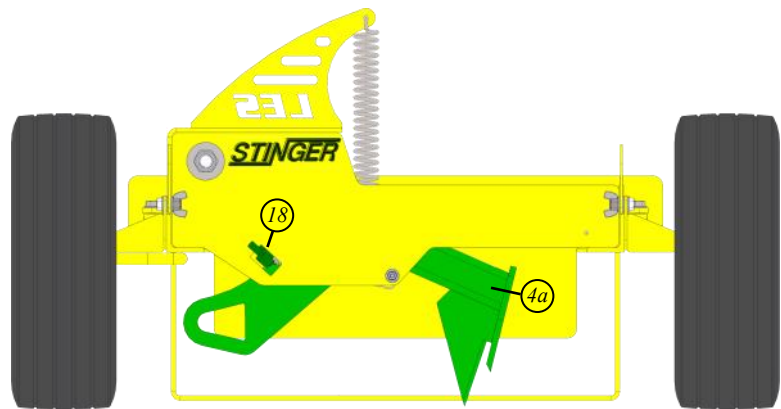

PROBLEM

STINGER does not roll easily or bounces when traveling due to flat spots on tires.

POSSIBLE CAUSE

Leaving the unit stationary in one location for too long a period of time.

SOLUTION

Rotate the tires or block the axles off the ground during long-term storage. Replace tires if flat spots prevent the unit from being moved easily.

STINGER™ INSTRUCTION MANUAL

E
N
G
L
I
S
H

APPENDIX B—REPLACING LOCKING PLATE ON ENGAGEMENT BOX

READ AND UNDERSTAND THE ENTIRE SET OF INSTRUCTIONS BEFORE PERFORMING ANY STEP IN THIS PROCESS

TOOLS NEEDED: Needle nose pliers

Locking Plate Removal

STEP 1

Locate *Locking Plate (18)* on the *Stinger Engagement Box Assembly (4)*.

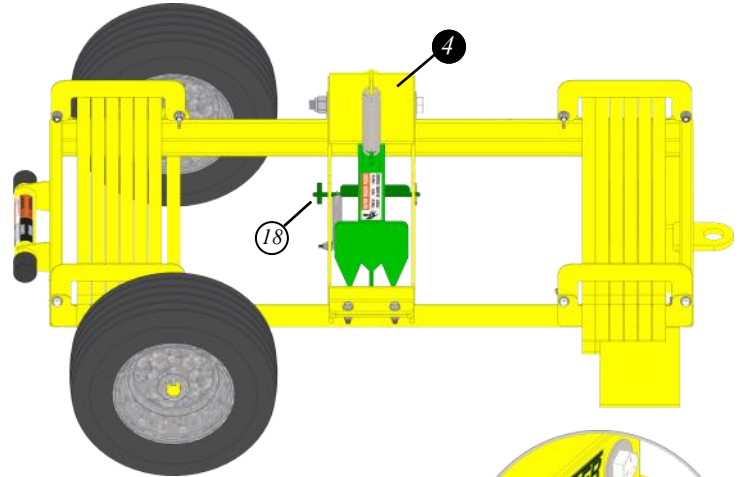

STEP 2

Remove the *Cotter Pin* from the *Locking Plate (18)*.

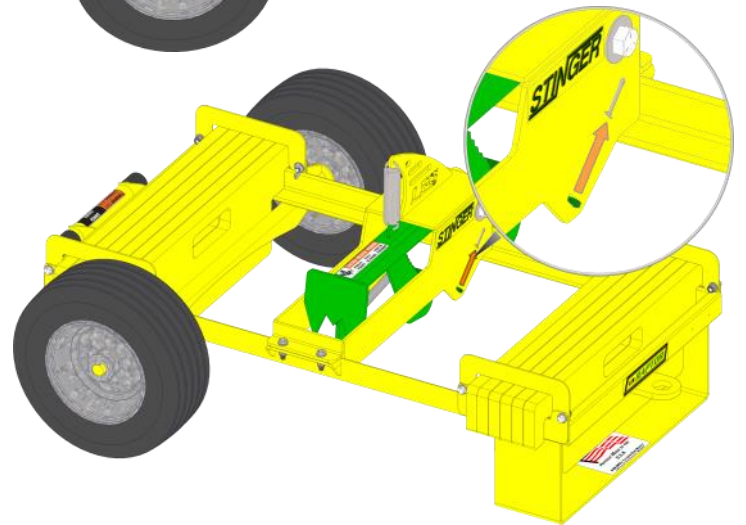

STEP 3

Remove *Locking Plate Spring (19)* from *Eye Bolt* first (1).

Next (2), remove *Locking Plate Spring (19)* from *Locking Plate (18)*.

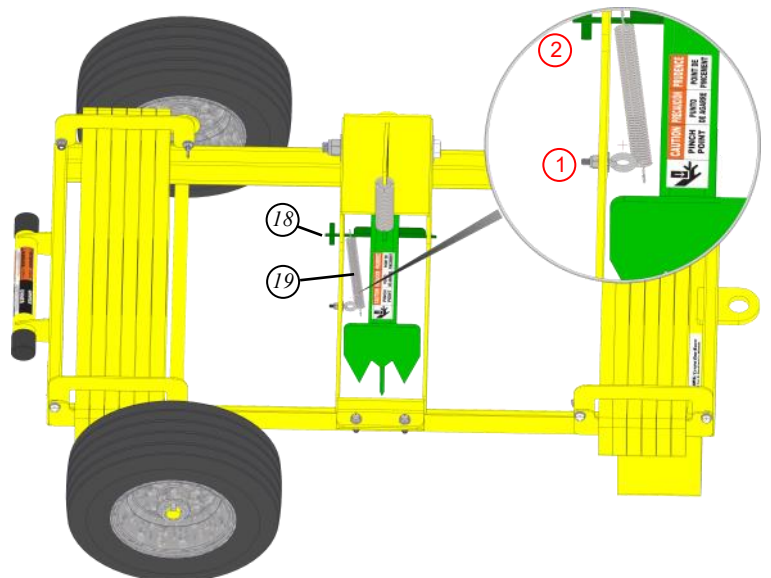

APPENDIX B—REPLACING LOCKING PLATE ON ENGAGEMENT BOX

READ AND UNDERSTAND THE ENTIRE SET OF INSTRUCTIONS BEFORE PERFORMING ANY STEP IN THIS PROCESS

STEP 4

Remove the Locking Plate (18) from the Stinger Engagement Box Assembly (4).

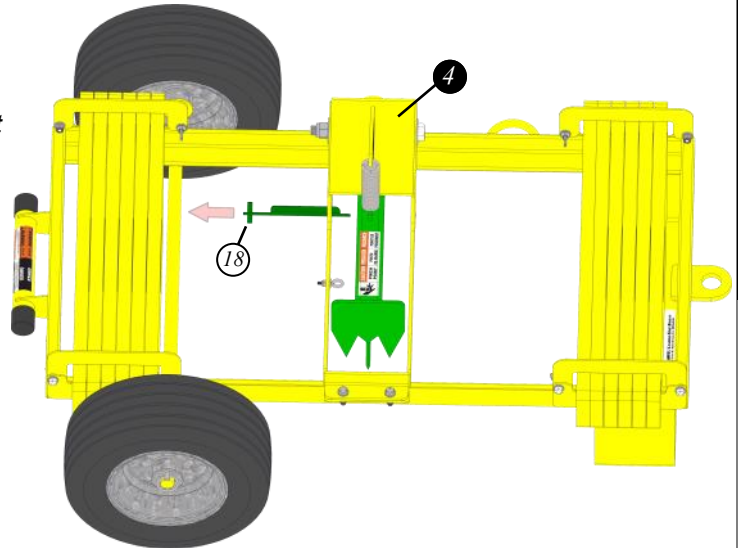

Locking Plate Installation

STEP 5

Insert Locking Plate (18) into the Stinger Engagement Box Assembly (4) as shown.

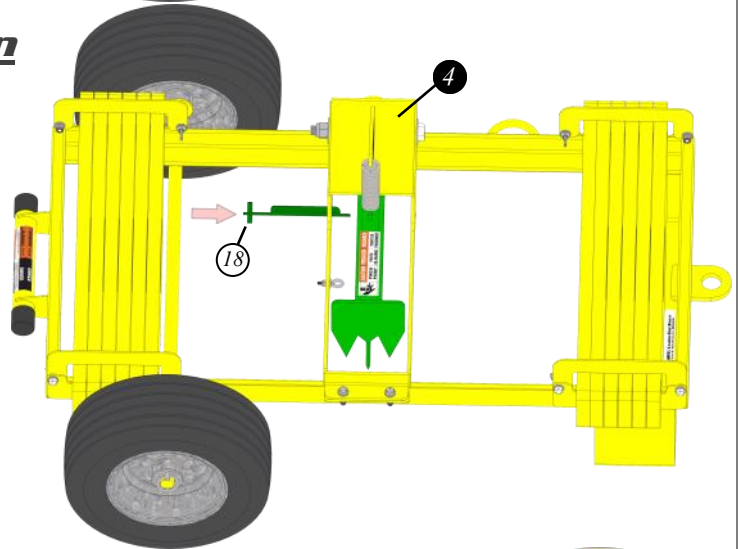

STEP 6

First (1), attach Locking Plate Spring (19) to the Locking Plate (18).

Next (2), attached the Locking Plate Spring (19) to the Eye Bolt.

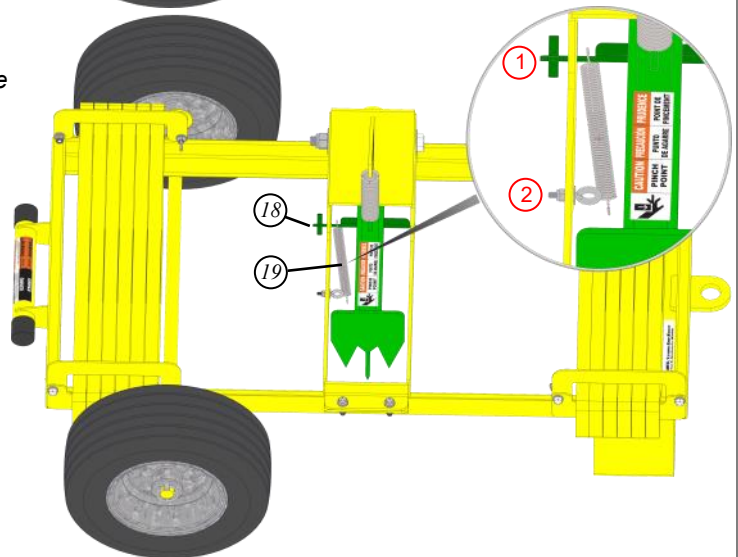

STINGER™ INSTRUCTION MANUAL

APPENDIX B—REPLACING LOCKING PLATE ON ENGAGEMENT BOX

READ AND UNDERSTAND THE ENTIRE SET OF INSTRUCTIONS BEFORE PERFORMING ANY STEP IN THIS PROCESS

E
N
G
L
I
S
H

STEP 7

Insert *Cotter Pin* into *Locking Plate (18)* as shown.

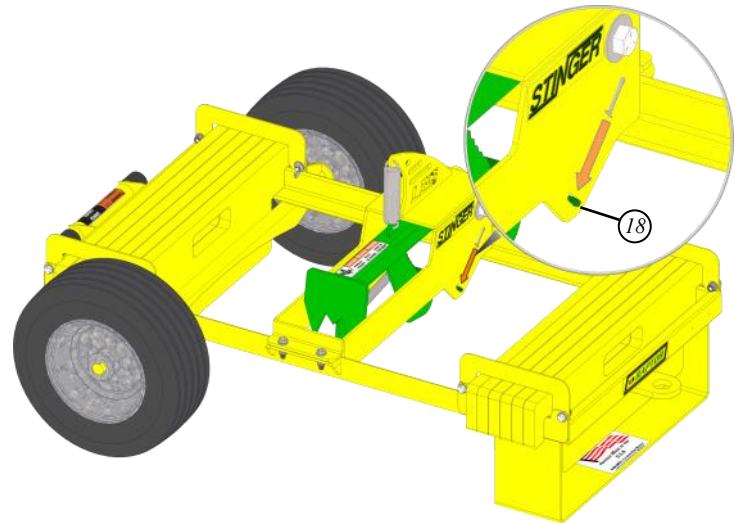

STEP 10

TESTING THE OPERATION OF THE CLAW

Lift upward on the *Locking Plate (18)* and press downward 1-2 inches on the *Engagement Arm*, release pressure on the *Engagement Arm* and the *Engagement Arm Spring (17)* should return the *Engagement Arm* to its raised position. Next, press downward on the *Engagement Arm* (do not disengage the *Locking Plate*) until the *Locking Plate (18)* engages. If the *Locking Plate (18)* engages, the unit is working properly and may be returned to service.

Disengage the *Locking Plate (18)* by pressing down on the *Engagement Arm* and lifting up on the *Locking Plate (18)*; release pressure on the *Engagement Arm*, allowing it to return to its raised position, then release the *Locking Plate (18)* to return to its resting position.

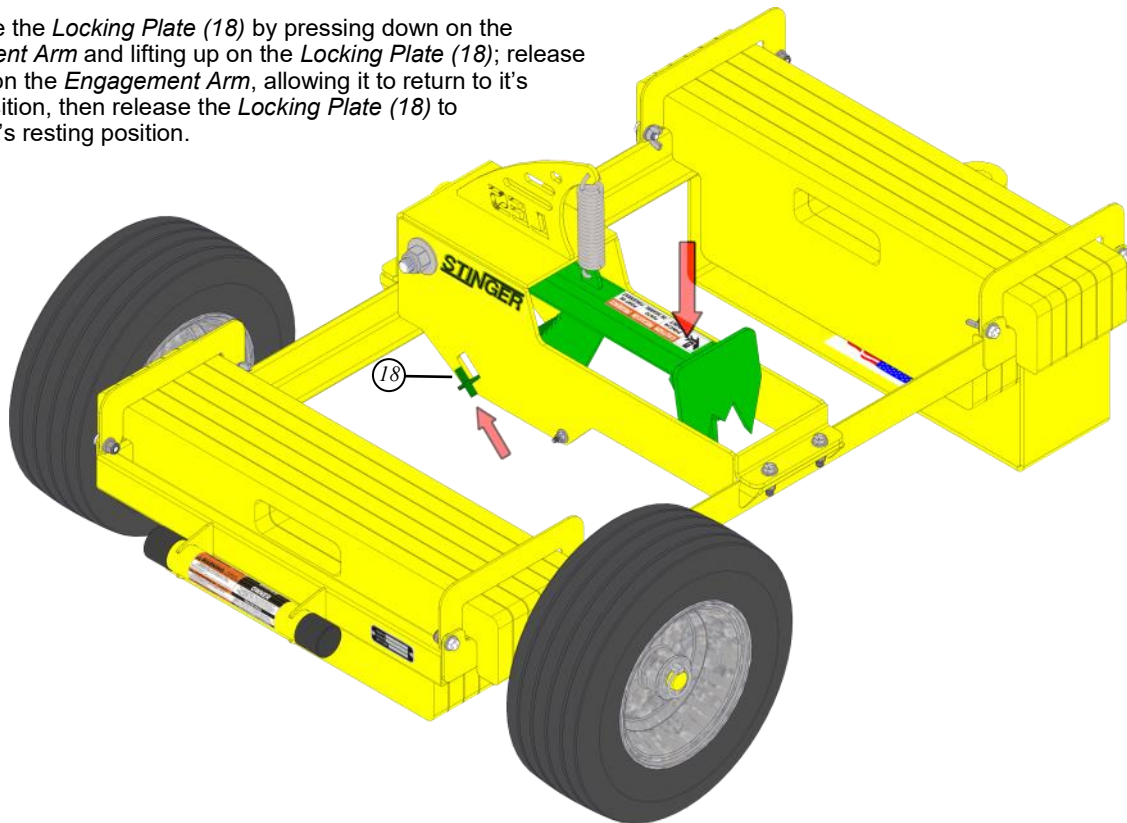

STINGER™ INSTRUCTION MANUAL

E
N
G
L
I
S
H

MOBILE FALL CART INSPECTION AND MAINTENANCE LOG

PLEASE COPY THIS LOG, FILL IT OUT BEFORE EACH USE, AND KEEP IT IN YOUR RECORDS.

EQUIPMENT MODEL #: _____

EQUIPMENT SERIAL #: _____

DATE OF PURCHASE: _____

INSPECTION DATE: _____

Inspection Item	Corrective Action Needed?		Maintenance Performed
	Yes	No	
Overall Cart Parts			_____

Inspected By: _____			_____
Welded Connections			_____

Inspected By: _____			_____
Attachment Point Rings and Hoisting Rings			_____

Inspected By: _____			_____
Engagement Box			_____

Inspected By: _____			_____
Engagement Arm Freely Moving			_____

Inspected By: _____			_____
Warning Labels			_____

Inspected By: _____			_____
Overall Cart Corrosion			_____

Inspected By: _____			_____



Copyright © 2020 by Leading Edge Safety, LLC
1345 Taney, North Kansas City, MO 64116
www.LeadingEdgeSafety.net

PRINTED IN THE UNITED STATES OF AMERICA