



www.scintex.com.au | sales@scintex.com.au

Model: SPS240VADEF & SPS240VADEFA

240V AdBlue Transfer Pump Stations

User's Manual





WARNING: Read carefully and understand all INSTRUCTIONS before operating. Failure to follow the safety rules and other basic safety precautions may result in serious personal injury.

A. MACHINE DESCRIPTION

PUMP: Self-priming, volumetric, diaphragm pump, equipped with by-pass valve.

MOTOR: Asynchronous motor, single-phase, 2 pole, closed type (protection class IP55 in conformance with EN 60034-5-86 regulations) self-ventilated.

B. TECHNICAL DATA

B1. Configuration

Item No.	Pump model	Voltage	Suction Hose	Delivery Hose	Nozzle	Flow Meter
SPS240VADEF	SAP240V25L	240V	1.5M	6M	Manual	Yes
SPS240VADEFA	SAP240V25L	240V	1.5M	6M	Auto	Yes

C. OPERATING CONDITIONS

C1. ENVIRONMENTAL CONDITIONS

TEMPERATURE: Min. -10oC (14°F) / Max. +60oC(140°F)

RELATIVE HUMIDITY: Max. 90%



ATTENTION!

The temperature limits shown should be adhered to, to prevent damage to the pump.

C2. ELECTRICAL POWER SUPPLY

Depending on the model, the pump must be supplied by a single-phase alternating current line whose nominal values are shown in the table in Paragraph B1 – ELECTRICAL SPECIFICATIONS.

The maximum acceptable variations from the electrical parameters are:

Voltage: +/-5% of the nominal value

Frequency: +/-2% of the nominal value



ATTENTION!

Power from lines with values outside the indicated limits can damage the electrical components.

C3. WORKING CYCLE

The pumps are designed for continuous use under maximum back pressure.



ATTENTION!

Functioning under by-pass conditions is only allowed for brief periods of time (2-3 minutes maximum).

C4. FLUIDS PERMITTED

PERMITTED

- Chemical products: Urea, weak acid & weak alkaline fluid etc.
- Water

D. MOVING AND TRANSPORT

Given the limited weight and size of the pumps (see overall dimensions), moving the pumps does not require the use of lifting devices.

E. INSTALLATION

E1. DISPOSING OF THE PACKING MATERIAL

The packing material does not require special precautions.

Refer to local regulations for its disposal.

E2. PRELIMINARY INSPECTION

- Check that the machine has not suffered any damage during transport or storage.
- Clean the inlet and outlet openings, removing any dust or residual packing material.
- Make sure that the motor shaft turns freely.
- Check that the electrical specifications correspond to those shown on the identification plate.



ATTENTION!

THE MOTORS ARE NOT ANTI-EXPLOSIVE. Do not install them where inflammable vapours can be present.

E3. CONNECTING

- Before connection, make sure that the tubing and the suction tank are free of dirt and thread residue that could damage the pump and its accessories.
- Do not use conical threaded joints that could damage the threaded pump openings if excessively tightened.

Step 1: SUCTION HOSE:

- Connect the 1.5M Suction hose by the Hose tail (#8) and Clamp (#12) to the inlet of the pump.

Step 2: DELIVERY HOSE:

- Connect the 6M Delivery hose by the Hose tail (#8) and Clamp (#12) to the outlet of the pump or the flow meter.

Step 3: FLOW METER (Optional):

- Connect the flow meter by the Elbow (#9) to the outlet of the pump.

Step 4: NOZZLE

- Connect the dispensing nozzle by the Clamp (#12) to the delivery hose.

E4. DISPENSING

After installation the completed pump system as picture indicated, connect the power supply, start pumping.



ATTENTION!

It is the installer's responsibility to use hose with adequate characteristics.

Loosening of the connections (threaded connections, flanging, gasket seals) can cause serious ecological and safety problem.

Check all the connections after the initial installation and on a daily basis after that.

Tighten the connections, if necessary.

F. DAILY USE

- a. If using flexible tubing, attach the ends of the tubing to the tanks. In the absence of an appropriate slot, solidly grasp the delivery tube before beginning dispensing.
- b. Before starting the pump, make sure that the delivery valve is closed (dispensing nozzle or line valve).
- c. Turn the ON/OFF switch to ON. The by-pass valve allows functioning with the delivery closed only for brief periods.
- d. Open the delivery valve, solidly grasping the end of the tubing.
- e. Close the delivery valve to stop dispensing.
- f. When dispensing is finished, turn off the pump.

 **ATTENTION!**

Function with the delivery closed is only allowed for brief periods (2-3 minutes maximum).

After using, make sure the pump is turned off.

G. PROBLEMS AND SOLUTIONS

PROBLEM	POSSIBLE CAUSE	CORRECTIVE ACTION
The Motor is not turning	Lack of electric power	Check the electrical connecting
	Motor Problems	Contact the Service Department
The motor turns slowly when starting	Low voltage in the electric power line	Bring the voltage back within the anticipated limits
Low or no flow rate	Low level in the suction tank	Refill the tank
	Filter clogged	Clean the filter
	Excessive suction pressure	Lower the pump with respect to the level of the tank or increase the cross-section of the tubing
	High loss of head in the delivery circuit (working with the by-pass open)	Use shorter tubing or of greater diameter
	By-pass valve blocked	Dismantle the valve, clean and/or replace it.
	Air entering the pump or the suction tubing	Check the seals of the Connections
	A narrowing in the suction tubing	Use tubing suitable for working under suction pressure
	Low rotation speed	Check the voltage at the pump. Adjust the voltage and/or use cables of greater cross-section
The suction tubing is resting on the bottom of the tank	Raise the tubing	
Increased pump noise	Cavitation occurring	Reduce suction pressure
	Irregular functioning of the by-pass	Dispense fluid until the air is purged from the by-pass system

H. MAINTENANCE

All models are designed and constructed to require a minimum of maintenance.

In any case always bear in mind the following basic recommendations for a good functioning of the pump:

- On a weekly basis, check that the tubing joints have not loosened, to avoid any leakage.
- On a monthly basis, check the pump body and keep it clean of any impurities.
- On a weekly basis, check and keep clean the line suction filter.
- On a monthly basis, check that the electric power supply cables are in good condition.

I. NOISE LEVEL

Under normal working conditions the noise emission from all models does not exceed the value of **80 db at a distance of 1 meter** from the electric pump.

J. DISPOSING OF CONTAMINATED MATERIALS

In the event of maintenance or demolition of the machine, do not disperse contaminated parts into the environment.

Refer to local regulations for their proper disposal.

K. DIAGRAM AND PARTS LIST

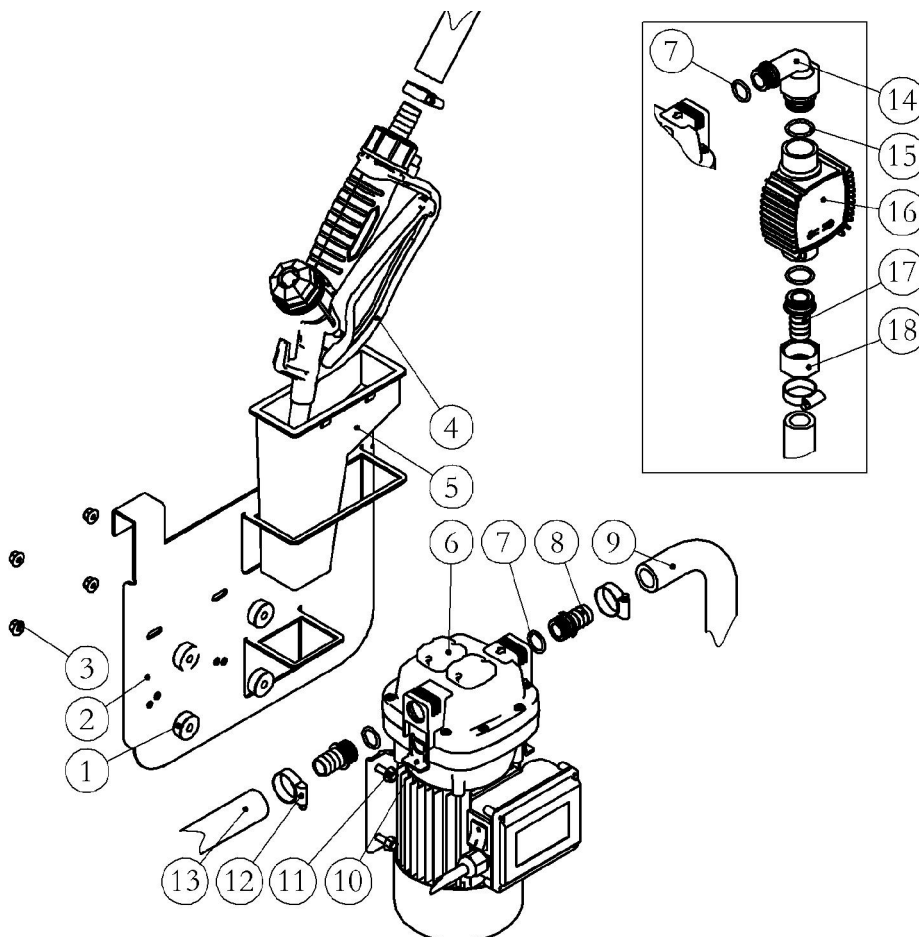

No.	Description	Qty
1	Crash gasket	4
2	Bracket	1
3	Nut	4
4	Nozzle	1
5	Nozzle holder	1
6	Electric pump	1
7	O-ring	2
8	Hose tail	2
9	Delivery hose	6.5m

No.	Description	Qty
10	Clip	2
11	Bolt	4
12	Hose clamp	3
13	Suction hose	1.5m
14	Elbow	1
15	O-ring	2
16	Flow meter	1
17	Hose tail	1
18	Lock nut	2

L.DIMENSIONAL DATA

