



USER MANUAL

AIR FRYER GRILL

Model: AFG01

CONTENTS

| | |
|-------------------------------------|----|
| Important Safety Instructions | 1 |
| Parts | 2 |
| Display Panel | 3 |
| Air Fry | 4 |
| Roast | 5 |
| Air Broil | 6 |
| Bake | 7 |
| Fries | 8 |
| Beef | 9 |
| Air grill | 10 |
| Cleaning | 11 |
| Troubleshooting Guide | 12 |

IMPORTANT SAFETY INSTRUCTIONS

- 1 This appliance is not intended for use by persons (including children) with reduced physical, sensory or mental capabilities, or lack of experience and knowledge, unless they have been given supervision or instruction concerning use of the appliance by a person responsible for their safety.
- 2 Children should be supervised to ensure that they do not play with the appliance.
- 3 If the supply cord is damaged, it must be replaced by the manufacturer, its service agent or similarly qualified persons in order to avoid a hazard.
- 4 The appliances are not intended to be operated by means of an external timer or separate remote-control system.
- 5 Keep the appliance and its cord out of reach of children. **DO NOT** allow the appliance to be used by children. Close supervision is necessary when used near children.
- 6 This appliance is for household use only. **DO NOT** use this appliance for anything other than its intended use. **DO NOT** use in moving vehicles or boats. **DO NOT** use outdoors. Misuse may cause injury.
- 7 When using this appliance, provide at least 6 inches (15.25cm) of space above and on all sides for air circulation.
- 8 **ALWAYS** use protective hot pads, insulated oven mitts, long handed utensil and use handles.
- 9 Ensure the surface is level, clean and dry. **DO NOT** place the appliance near the edge of a countertop during operation. **ALWAYS** ensure the appliance is properly assembled before use.
- 10 **DO NOT** place anything on top of the appliance.
- 11 **DO NOT** use the appliance for any purpose other than described in this manual.
- 12 Keep all ingredients in the basket to prevent any contact with the appliance's heating elements. Since the ingredients may become bigger after heating. **DO NOT** overfill the basket.
- 13 To protect against electrical shock. **DO NOT** immerse cord, plugs, or main unit housing in water or other liquid.
- 14 **DO NOT** touch the inner pot edge, outer casing, roast basket handle, grill grate handle and the surface of the upper cover during use to avoid burns.
- 15 **WARNING: Hot Surfaces.**
Attention: Before first use, remove all promotional stickers and packaging materials, and clean the inner pot, top cover, etc. on the machine.
- 16 During and after cooking, the fryer basket and grill are very hot and **DO NOT** touch directly by hand. Please use oven mitts to remove the basket and grill.
- 17 During hot air frying, hot steam is released through the air outlets. Keep your hands and face at a safe distance from the steam and from the air outlets. Also be careful of hot steam and air when you remove the pan from the appliances.
- 18 To disconnect, turn unit to "oFF", then unplug from socket when not in use and before cleaning.

PARTS

Cooking Pot

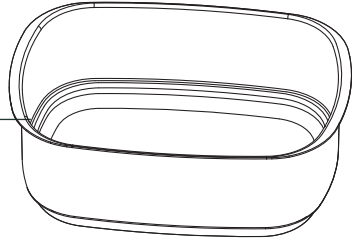

Roast Basket

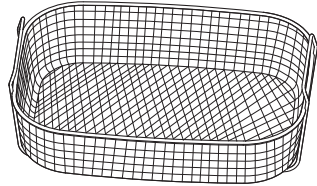

Grill Grate

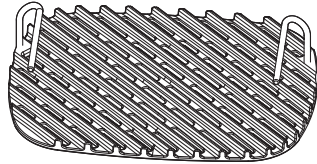

Cover Handle

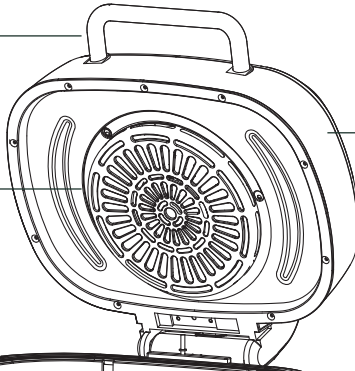

Cover

Heating Element

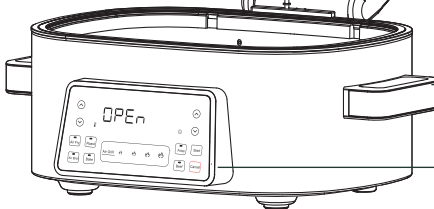
Main Unit
Handle

Touch Panel

DISPLAY PANEL



Function Buttons:

| | | | |
|--|--------------------------------|------------------|--|
| | Press to decrease temperature. | | Press to select Fries function. |
| | Press to increase temperature. | <u>Air Grill</u> | Press to select Air Grill function (low, medium, high, max). |
| | Press to increase time. | | Press to select Roast function. |
| | Press to decrease time. | | Press to select Bake function. |
| | Press to start cooking. | | Press to select Air Broil function. |
| | Press to cancel cooking. | | Press to select Air Fry function. |

AIR FRY

1. Press "Air Fry", default temperature and time appear on the panel.



2. Press to adjust the temperature and time.



3. Press "Start" to start preheating, "PrE" appear on the panel.

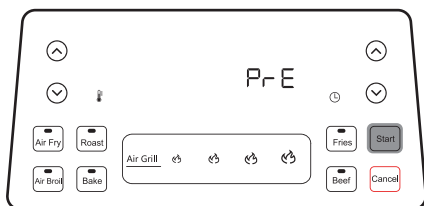

4. When preheating finished, "Add" appear on the panel. Open the cover and the unit stop working, "OPEn" appear on the panel.

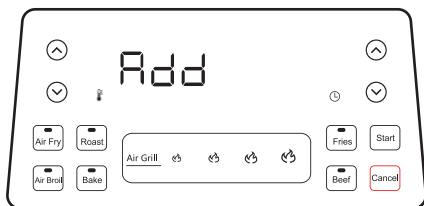

5. Put in the roast basket and ingredients, close the cover and the unit start counting down automatically.

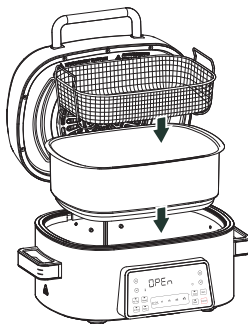

6. When the time countdown finished, "donE" blinked on the panel.



7. Press "Cancel" to standby mode, "OFF" appear on the panel.

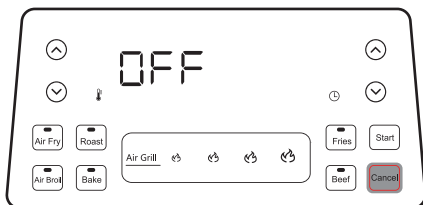

ROAST

1. Press "**Roast**", default temperature and time appear on the panel.



2. Press to adjust the temperature and time.



3. Press "**Start**" to start preheating, "PrE" appear on the panel.



4. When preheating finished, "Add" appear on the panel. Open the cover and the unit stop working, "OPEN" appear on the panel.

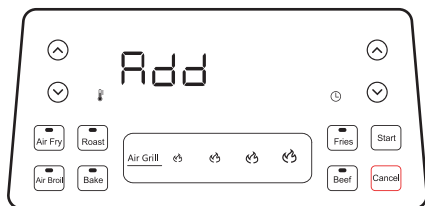

5. Put in the roast basket and ingredients, close the cover and the unit start counting down automatically.

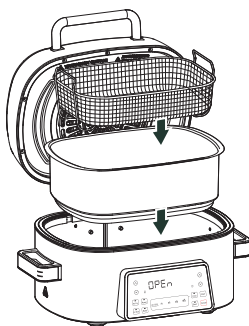

6. When the time countdown finished, "donE" blinked on the panel.



7. Press "**Cancel**" to standby mode, "OFF" appear on the panel.

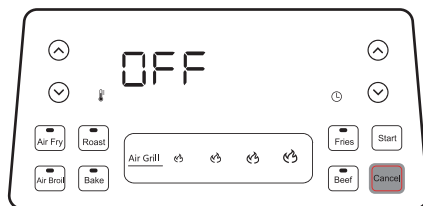

AIR BROIL

1. Press **"Air Broil"**, default temperature and time appear on the panel.

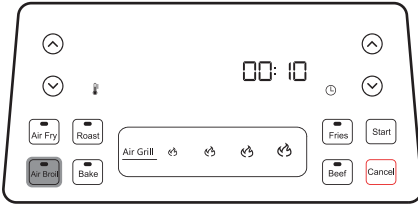

2. Press to adjust the time.

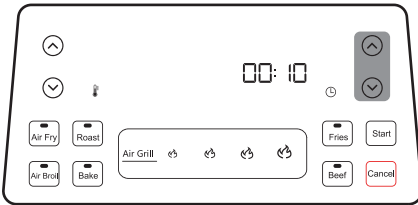

3. Press **"Start"** to start preheating, **"PrE"** appear on the panel.

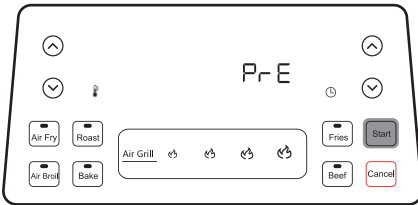

4. When preheating finished, **"Add"** appear on the panel. Open the cover and the unit stop working, **"OPEn"** appear on the panel.



5. Put in the roast basket and ingredients, close the cover and the unit start counting down automatically.

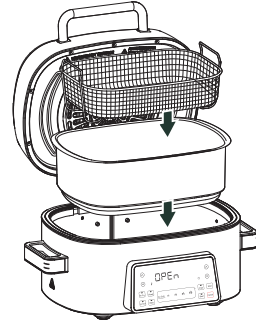

6. When the time countdown finished, **"done"** blinked on the panel.



7. Press **"Cancel"** to standby mode, **"OFF"** appear on the panel.



BAKE

1. Press "**Bake**", default temperature and time appear on the panel.

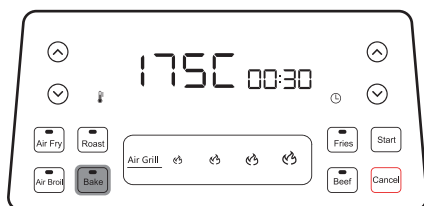

2. Press to adjust the temperature and time.



3. Press "**Start**" to start preheating, "PrE" appear on the panel.

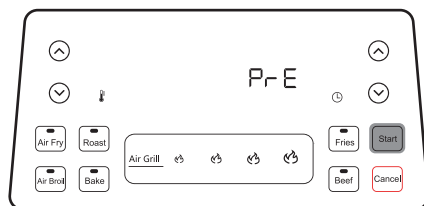

4. When preheating finished, "Add" appear on the panel. Open the cover and the unit stop working, "OPEn" appear on the panel.

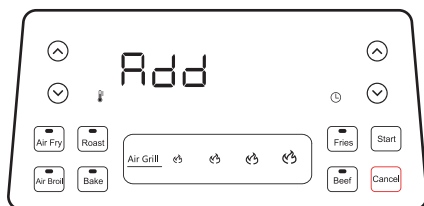

5. Put in the roast basket and ingredients, close the cover and the unit start counting down automatically.

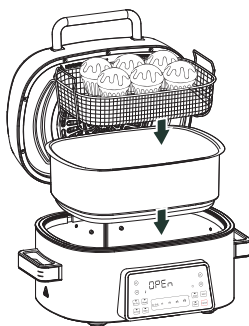

6. When the time countdown finished, "donE" blinked on the panel.



7. Press "**Cancel**" to standby mode, "OFF" appear on the panel.



FRIES

1. Press **"Fries"**, default temperature and time appear on the panel.

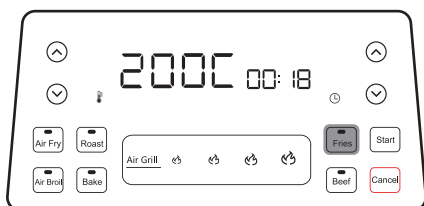

2. Press to adjust the temperature and time.



3. Press **"Start"** to start preheating, "PrE" appear on the panel.



4. When preheating finished, "Add" appear on the panel. Open the cover and the unit stop working, "OPEn" appear on the panel.

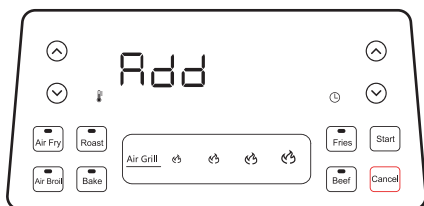

5. Put in the roast basket and ingredients, close the cover and the unit start counting down automatically.

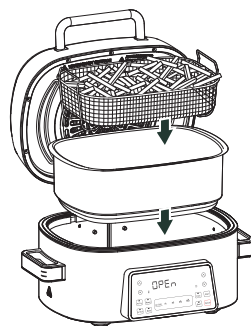

6. When the time countdown finished, "done" blinked on the panel.



7. Press **"Cancel"** to standby mode, "OFF" appear on the panel.

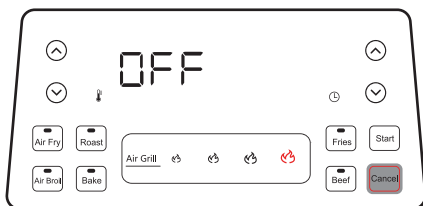

Note: For best cooking results, it is recommended to shake your food during cooking.

When you open the cover, the unit will stop automatically and "OPEn" appear on the panel. Use the oven mitts to shake the basket. Cooking will resume when the basket is back and the cover is closed.

BEEF

1. Press "**Beef**", default temperature and time appear on the panel.



2. Add the grill grate in the pot.

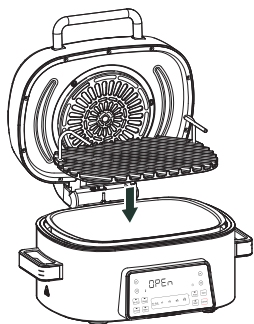

3. Press to adjust the temperature and time.



4. Press "**Start**" to start preheating, "PrE" appear on the panel.

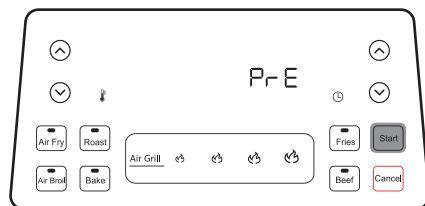

5. When preheating finished, "Add" appear on the panel. Open the cover and the unit stop working, "OPEN" appear on the panel.

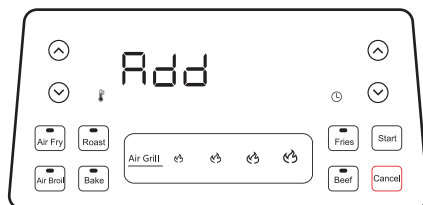

6. Place the ingredients on the grill grate, close the cover and the unit start cooking automatically.

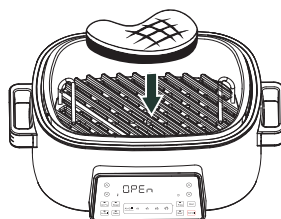

7. When the time countdown finished, "done" blinked on the panel.



8. Press "**Cancel**" to standby mode, "OFF" appear on the panel.

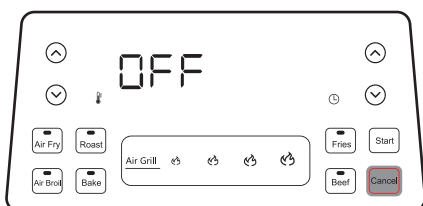

AIR GRILL

| Function | Default | Temperature range | Time range |
|--------------------|----------------|-------------------|----------------------|
| Air Grill (low) | 200°C 00:15 | / | 1-30min 1min/step |
| Air Grill (medium) | 220°C 00:15 | / | |
| Air Grill (high) | 240°C 00:15 | / | |
| Air Grill (Max) | 265°C 00:10 | / | |

1. Press "🔥" to select desired mode of air grill. Default time and temperature appear on the panel.

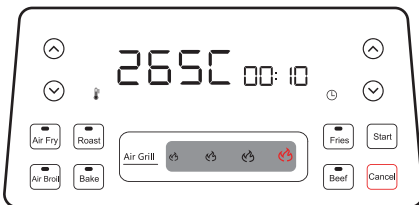

2. Place the grill grate in the pot.

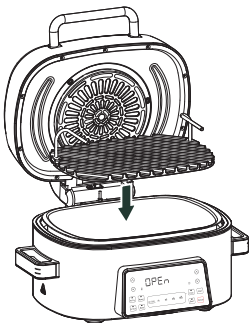

3. Press to adjust the time. Press "Start" to start preheating, "PrE" appear on the panel.



4. When preheating finished, "Add" appear on the panel. Open the cover and the unit stop working, "OPEn" appear on the panel.

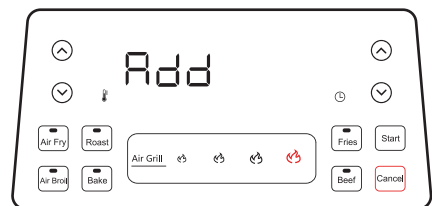

5. Place the ingredients on the grill grate, close the cover and the unit start cooking automatically.

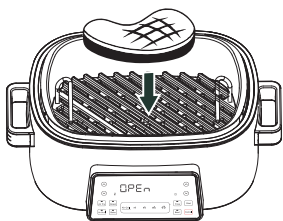

6. When the time countdown finished, "donE" blinked on the panel.



7. Press "Cancel" to standby mode, "OFF" appear on the panel.



Note: During cooking, you can open the cover to check the food or flip it.

Unit will automatically pause when the cover is opened, then resume cooking when the cover is closed.

CLEANING

The unit should be cleaned thoroughly after every use. Always let the appliance cool before cleaning.

Unplug the unit from the wall outlet before cleaning.

1. Remove the main plug from the wall outlet and let the appliance cool down for at least 30 minutes.
2. Remove the accessories to let the air fryer cool before cleaning.
3. **DO NOT** clean the accessories and the inside of the appliance with any metal kitchen utensils or abrasive cleaning materials, as this may damage the coating.
4. Wipe the outside of appliance with a moist cloth.
5. Clean accessories with hot water, some liquid detergent and a non-abrasive sponge.
6. You can remove any remaining food residue with degreasing liquid.
7. The cleaned parts must be wiped dry before plugging in.

TROUBLESHOOTING GUIDE

• "Add" appears on the touch panel display.

The unit has completed its Grill preheating and it is now time to add your ingredients.

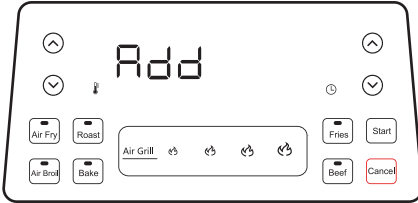

• E1 or E2 appear on display

The unit is not functioning properly. Please contact after-sales service.



• How do I pause the unit so I can check my food?

When the hood is opened during a cooking function, the unit will automatically pause. The display will show "OPEN".



• Is it safe to put the cooking pot on my countertop?

The pot will heat during cooking. Use caution when handling, and place on heat-safe surfaces only.

• My food was not cooked after cooking

For consistent browning, make sure ingredients are arranged in an even layer on the bottom of the roast rack with no overlapping. Shake loose ingredients during cooking.

• Taking too long to preheat?

The grill needs to absorb more heat for optimal cooking results, so it may take longer to preheat when the room temperature is low. If you determine that the internal temperature of the pan is high enough, you can manually skip preheating.

• How to skip preheating?

When the device is in preheat mode "PrE" is displayed, press and hold the "Start" for 3 seconds to skip the preheat. Preheat can only be skipped in preheat mode.

• Handle this product correctly

 This marking indicates this product should not be disposed of with other household wastes throughout the EU. To prevent possible harm to the environment or human health from uncontrolled waste disposal, recycle it responsibly to promote the sustainable reuse of material sources. To return your used device, please use the return and collection systems or contact the retailer where this product was purchased. They can take this product for environmentally safe recycling.

INHALT

| | |
|------------------------------------|----|
| Wichtige Sicherheitshinweise | 13 |
| Beschreibung der Teile | 14 |
| Anzeigetafel | 15 |
| Luftfrittieren | 16 |
| Rösten | 17 |
| Luftbraten Funktion | 18 |
| Backen | 19 |
| Pommes | 20 |
| Rindfleisch | 21 |
| Luftgrillen | 22 |
| Renigen | 23 |
| Fehlerbehebung | 24 |

WICHTIGE SICHERHEITSHINWEISE

- 1 Dieses Gerät ist nicht dafür geeignet, von Personen (einschließlich Kindern) mit verminderten physischen, sensorischen oder geistigen Fähigkeiten oder einem Mangel an Erfahrung und Kenntnis verwendet werden, es sei denn, sie werden von einer für ihre Sicherheit verantwortlichen Person in der Benutzung des Geräts beaufsichtigt oder unterwiesen.
- 2 Kinder sollten beaufsichtigt werden, um sicherzustellen, dass sie die Geräte nicht benutzen.
- 3 Wenn das Netzkabel beschädigt ist, **MUSS** es vom Hersteller, seinem Kundendienst oder einer ähnlich qualifizierten Person ersetzt werden, um eine Gefährdung zu vermeiden.
- 4 Das Gerät kann nicht über eine externe Zeitschaltuhr oder ein separates Fernbedienungssystem gesteuert werden.
- 5 Das Gerät und sein Netzkabel sollten außerhalb der Reichweite von Kindern aufbewahrt werden. Erlaubt man Kindern **NICHT**, das Gerät zu benutzen. Bei Verwendung in der Nähe von Kindern müssen diese unbedingt strikt beaufsichtigt werden.
- 6 Dieses Gerät ist **NUR** für den Gebrauch im Haushalt vorgesehen. Verwenden Sie dieses Gerät **NICHT** für andere als die vorgesehenen Zwecke. Benutzen Sie dieses Gerät **NICHT** in fahrenden Fahrzeugen oder Booten. Verwenden Sie das Gerät **NICHT** im Freien. Zweckentfremdung kann zu Verletzungen führen.
- 7 Achten Sie bei der Verwendung dieses Geräts darauf, dass oben und an allen Seiten mindestens 6 Zoll (15,25 cm) für die Luftzirkulation vorhanden ist.
- 8 Verwenden Sie immer langstielige Utensilien, Wärmeschutzpolster oder isolierte Ofenhandschuhe und benutzen Sie Griffe.
- 9 Stellen Sie sicher, dass die Oberfläche eben, sauber und trocken ist. Stellen Sie das Gerät während der Nutzung nicht in Nähe der Kante der Arbeitsfläche auf. Immer sicherstellen, dass das Gerät vor dem Gebrauch richtig montiert ist.
- 10 Stellen Sie bitte **KEINE** Gegenstände auf dem Gerät ab.
- 11 Verwenden Sie bitte dieses Produkt **NICHT FÜR ANDERE** als die in diesem Handbuch beschriebenen Zweck.
- 12 Lassen Sie alle Zutaten im Korb, damit sie nicht mit den Heizelementen des Geräts in Berührung kommen. Da die Zutaten nach dem Erhitzen größer werden können, darf der Korb nicht überfüllt werden.
- 13 Um Stromschläge zu vermeiden, tauchen Sie das Kabel, den Stecker sowie Gehäusesteile des Mainframes niemals in Wasser oder andere Flüssigkeiten.
- 14 Berühren Sie während des Gebrauchs nicht den Rand des Innentopfs, das Gehäuse, den Griff des Frittierkorbs, den Griff des Grills und die Oberfläche des Deckels, um Verbrennungen zu vermeiden.
- 15 **Warnung:** Hohe Oberflächentemperatur. **Hinweis:** Entfernen Sie vor dem ersten Gebrauch alle Werbeaufkleber und das Verpackungsmaterial und reinigen Sie den Innentopf, die obere Abdeckung und andere Teile des Geräts.
- 16 Während und am Ende des Kochens sind der Frittierkorb und der Grill sehr heiß und sollten nicht direkt mit der Hand berührt werden. Bitte benutzen Sie Ofenhandschuhe, um den Korb und der Grill zu entfernen.
- 17 Während des Heißluftfritierens wird heißer Dampf durch den Luftauslass freigesetzt. Halten Sie Ihre Hände und Ihr Gesicht in einem sicheren Abstand zum Dampf- und Luftauslass. Seien Sie vorsichtig mit heißem Dampf und Luft, wenn Sie die Pfanne aus dem Gerät nehmen.
- 18 Schalten Sie das Gerät aus und ziehen Sie den Stecker aus der Steckdose, wenn Sie es nicht benutzen und bevor Sie es reinigen.

BESCHREIBUNG DER TEILE

Kochtopf

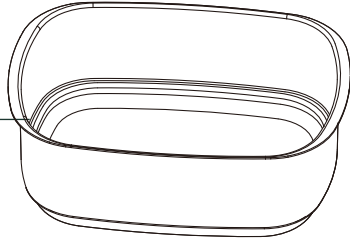

Grillkorb

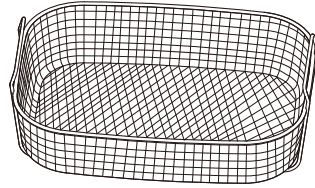

Grillrost

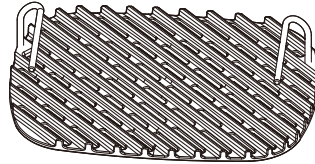

Griff des Deckels

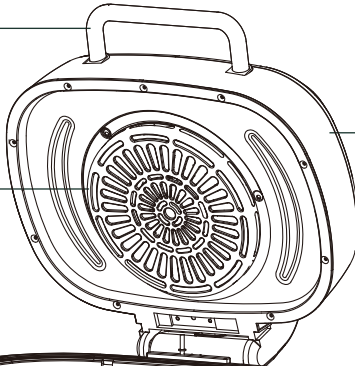

Deckel

Heizelemente

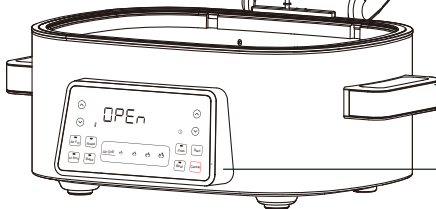





Handgriff der
Haupteinheit

Anzeigtabelle

ANZEIGETAFEL



Operation:

| | |
|--|---|
| <p> Drücken Sie diese Taste, um die Temperatur zu verringern.</p> <p> Drücken Sie diese Taste, um die Temperatur zu erhöhen.</p> | <p> Drücken Sie diese Taste, um die Funktion Pommes frites zu wählen.</p> <p><u>Air Grill</u>     Drücken Sie diese Taste, um die Grillfunktion der Fritteuse auszuwählen (niedrig, mittel-niedrig, mittel, hoch).</p> |
| <p> Drücken Sie diese Taste, um die Zeit zu erhöhen.</p> <p> Drücken Sie diese Taste, um die Zeit zu verringern.</p> | <p> Drücken Sie diese Taste, um die Funktion Braten zu wählen.</p> <p> Drücken Sie diese Taste, um die Funktion Backen zu wählen.</p> |
| <p> Drücken Sie diese Taste, um das Kochen zu starten.</p> | <p> Drücken Sie diese Taste, um die Funktion Luftgrillen zu wählen.</p> |
| <p> Drücken Sie diese Taste, um das Kochen abubrechen.</p> | <p> Drücken Sie diese Taste, um die Funktion Luftbraten zu wählen.</p> |

LUFTFRITTIEREN

1. Drücken Sie die Taste „Air Fry“, und die Standardtemperatur und -zeit werden angezeigt.

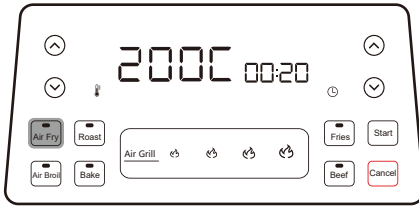

2. Drücken Sie die Taste und die Standardtemperatur und -zeit werden angezeigt.



3. Drücken Sie die Taste „Start“ um die Aufwärmphase zu starten; auf dem Display erscheint „PrE“.

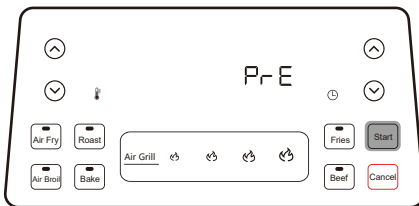

4. Wenn die Vorwärmung abgeschlossen ist, wird „Add“ angezeigt, der Deckel wird geöffnet, das Gerät schaltet sich aus und auf dem Display erscheint „OPEN“.

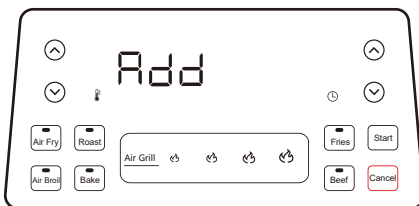

5. Fügen Sie den Bratenkorb und die Zutaten hinzu, schließen Sie den Deckel und das Gerät beginnt automatisch mit dem Herunterzählen.

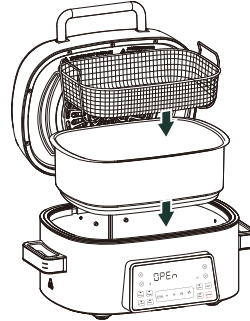

6. Wenn der Zeitcountdown beendet ist, blinkt „done“ auf dem Display.



7. Drücken Sie die Taste „Cancel“ um in den Standby-Modus zu wechseln, auf dem Display erscheint „OFF“.



RÖSTEN

1. Drücken Sie die Taste „Roast“, und die Standardtemperatur und -zeit werden angezeigt.



2. Drücken Sie die Taste, um die Temperatur und die Zeit einzustellen.



3. Drücken Sie die Taste „Start“ um die Aufwärmphase zu starten; auf dem Display erscheint „PrE“.

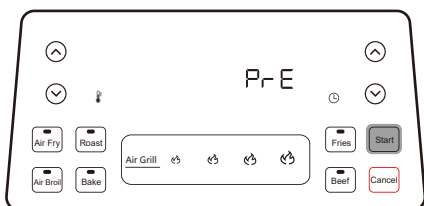

4. Wenn die Vorwärmung abgeschlossen ist, wird „Add“ angezeigt, der Deckel wird geöffnet, das Gerät schaltet sich aus und auf dem Display erscheint „OPEn“.



5. Fügen Sie den Bratenkorb und die Zutaten hinzu, schließen Sie den Deckel und das Gerät beginnt automatisch mit dem Herunterzählen.

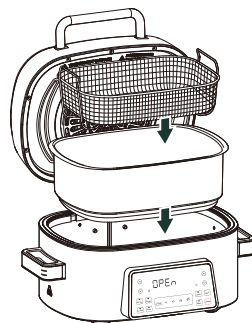

6. Wenn der Zeitcountdown beendet ist, blinkt „donE“ auf dem Display.



7. Drücken Sie die Taste „Cancel“ um in den Standby-Modus zu wechseln, auf dem Display erscheint „OFF“.

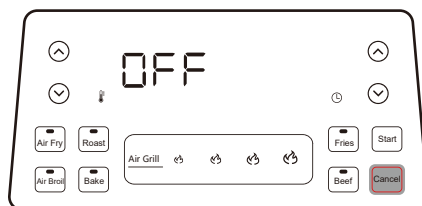

LUFTBRATEN FUNKTION

1. Drücken Sie die Taste „**Air Broil**“, und die Standardtemperatur und -zeit werden angezeigt.

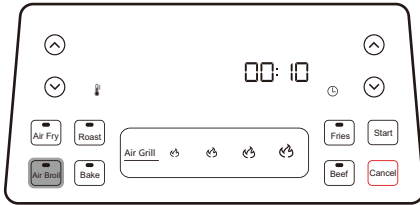

2. Drücken Sie die Taste, um die Zeit einzustellen.

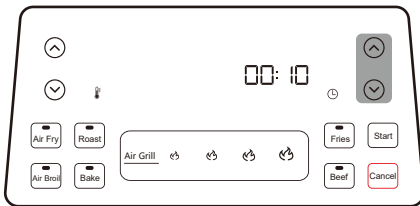

3. Drücken Sie die Taste „**Start**“ um die Aufwärmphase zu starten; auf dem Display erscheint „PrE“.

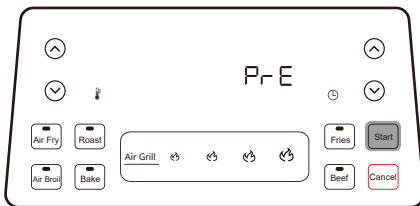

4. Wenn die Vorwärmung abgeschlossen ist, wird „Add“ angezeigt, der Deckel wird geöffnet, das Gerät schaltet sich aus und auf dem Display erscheint „OPEN“.



5. Fügen Sie den Bratenkorb und die Zutaten hinzu, schließen Sie den Deckel und das Gerät beginnt automatisch mit dem Herunterzählen.

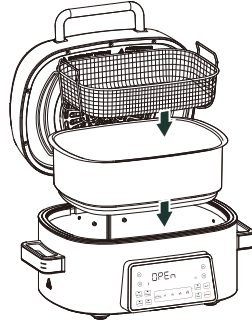

6. Wenn der Zeitcountdown beendet ist, blinkt „done“ auf dem Display.



7. Drücken Sie die Taste „**Cancel**“ um in den Standby-Modus zu wechseln, auf dem Display erscheint „OFF“.



BACKEN

1. Drücken Sie die Taste „**Bake**“, und die Standardtemperatur und -zeit werden angezeigt.



2. Drücken Sie die Taste, um die Temperatur und die Zeit einzustellen.



3. Drücken Sie die Taste „**Start**“ um die Aufwärmphase zu starten; auf dem Display erscheint „**PrE**“.

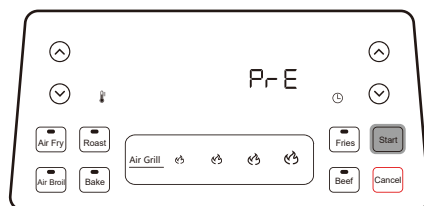

4. Wenn die Vorwärmung abgeschlossen ist, wird „**Add**“ angezeigt, der Deckel wird geöffnet, das Gerät schaltet sich aus und auf dem Display erscheint „**OPEN**“.

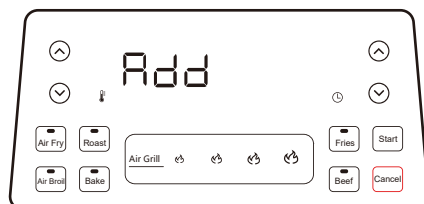

5. Fügen Sie den Bratenkorb und die Zutaten hinzu, schließen Sie den Deckel und das Gerät beginnt automatisch mit dem Herunterzählen.

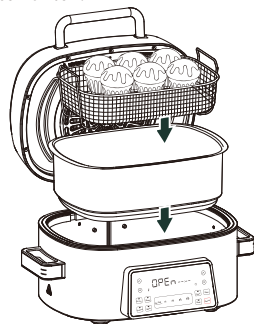

6. Wenn der Zeitcountdown beendet ist, blinkt „**done**“ auf dem Display.



7. Drücken Sie die Taste „**Cancel**“ um in den Standby-Modus zu wechseln, auf dem Display erscheint „**OFF**“.



POMMES

1. Drücken Sie die Taste „Fries“, und die Standardtemperatur und -zeit werden angezeigt.



2. Drücken Sie die Taste, um die Temperatur und die Zeit einzustellen.



3. Drücken Sie die Taste „Start“ um die Aufwärmphase zu starten; auf dem Display erscheint „PrE“.

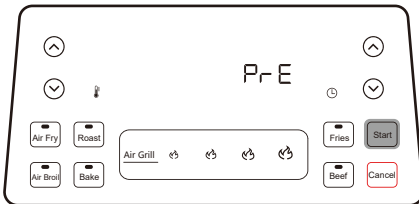

4. Wenn die Vorwärmung abgeschlossen ist, wird „Add“ angezeigt, der Deckel wird geöffnet, das Gerät schaltet sich aus und auf dem Display erscheint „Open“.

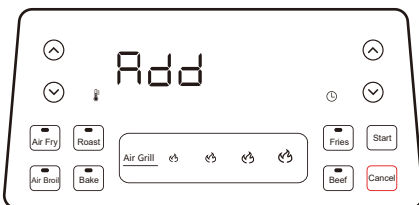

5. Fügen Sie den Bratenkorb und die Zutaten hinzu, schließen Sie den Deckel und das Gerät beginnt automatisch mit dem Herunterzählen.

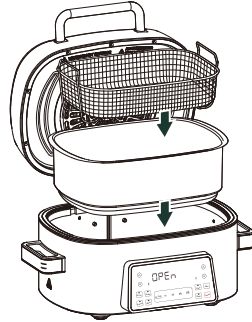

6. Wenn der Zeitcountdown beendet ist, blinkt „done“ auf dem Display.



7. Drücken Sie die Taste „Cancel“ um in den Standby-Modus zu wechseln, auf dem Display erscheint „OFF“.



Hinweis: Für beste Kochergebnisse empfehlen wir, die Zutaten während des Kochvorgangs zu schütteln.

Wenn Sie den Deckel öffnen, schaltet sich das Gerät automatisch ab und auf dem Display erscheint „OPEN“. Verwenden Sie den Topfhandschuh, um den Frittierkorb zu schütteln. Wenn der Korb zurückgestellt und der Deckel geschlossen wird, wird das Kochen fortgesetzt.

RINDFLEISCH

1. Drücken Sie die Taste **„Beef“**, und die Standardtemperatur und -zeit werden angezeigt.



2. Geben Sie bitte den Grill in den Topf.

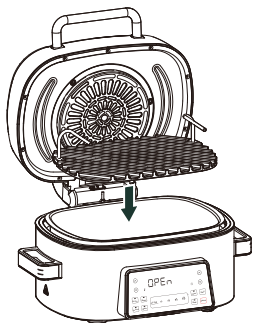

3. Drücken Sie die Taste, um die Temperatur und die Zeit einzustellen.



4. Drücken Sie die Taste **„Start“** um die Aufwärmphase zu starten; auf dem Display erscheint **„PrE“**.

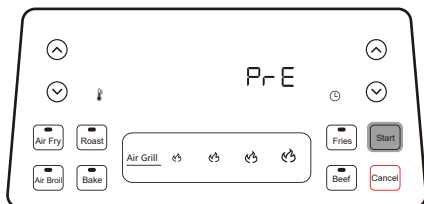

4. Wenn die Vorwärmung abgeschlossen ist, wird **„Add“** angezeigt, der Deckel wird geöffnet, das Gerät schaltet sich aus und auf dem Display erscheint **„OPEn“**.



6. Geben Sie die Zutaten auf den Grill, schließen Sie den Deckel und das Gerät beginnt automatisch mit dem Garen.

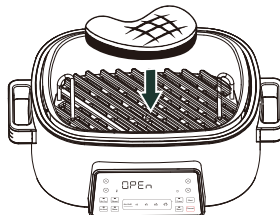

7. Wenn der Zeitcountdown beendet ist, blinkt **„donE“** auf dem Display.



8. Drücken Sie die Taste **„Cancel“** um in den Standby-Modus zu wechseln, auf dem Display erscheint **„OFF“**.



LUFTGRILLEN

| Funktion | Default | Temperrahmen | Zeitrahen |
|----------------------------|----------------|--------------|----------------------|
| Air Grill (niedrig) | 200°C 00:15 | / | 1-30min 1min/step |
| Air Grill (mittel-niedrig) | 220°C 00:15 | / | |
| Air Grill (mittel) | 240°C 00:15 | / | |
| Air Grill (hoch) | 265°C 00:10 | / | |

1. Drücken Sie die Taste „🔥“ um den gewünschten Airgrillmodus auszuwählen. Die Standardzeit und-Temperatur erscheinen auf dem Display.

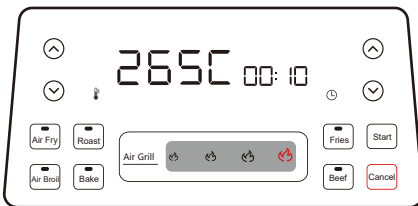

2. Geben Sie bitte den Grill in den Topf.

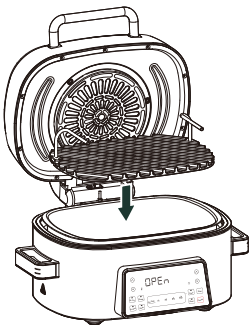

3. Drücken Sie die Taste um die die Zeit einzustellen. Drücken Sie die Taste „Start“ um die Aufwärmphase zu starten; auf dem Display erscheint „PrE“.



4. Wenn die Vorwärmung beendet ist, erscheint „Add“ auf dem Display, öffnen Sie den Deckel und das Gerät hört auf zu arbeiten, „OPEN“ erscheint auf dem Display.



5. Geben Sie die Zutaten auf den Grill, schließen Sie den Deckel und das Gerät beginnt automatisch mit dem Garen.

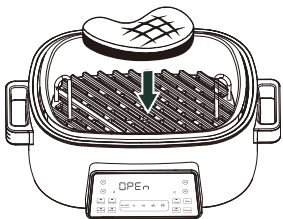

6. Wenn der Zeitcountdown beendet ist, blinkt „done“ auf dem Display.



7. Drücken Sie die Taste „Cancel“ um in den Standby-Modus zu wechseln, auf dem Display erscheint „OFF“.



Hinweis: Während des Garvorgangs können Sie den Deckel öffnen, um das Gargut zu prüfen oder zu wenden; das Gerät unterbricht automatisch, wenn der Deckel geöffnet wird, und setzt den Garvorgang fort, wenn er geschlossen wird.

REINIGEN

Das Gerät sollte nach **JEDEM** Gebrauch gründlich gereinigt werden.

Lassen Sie das Gerät vor der Reinigung **IMMER** abkühlen.

Ziehen Sie vor der Reinigung den Stecker aus der Steckdose

1. Ziehen Sie den Netzstecker aus der Steckdose und lassen Sie das Gerät mindestens 30 Minuten lang abkühlen.
2. Entfernen Sie das Zubehör und lassen Sie die Luftfritteuse vor der Reinigung abkühlen.
3. Reinigen Sie bitte das Gerät nach **JEDEM** Gebrauch
Verwenden Sie **KEINE** metallischen Küchenutensilien oder scheuernde Reinigungsmittel, um das Innere der Zubehör und Geräte zu reinigen, da dies die Beschichtung beschädigen kann.
4. Wischen Sie die Außenseite des Geräts mit einem feuchten Tuch ab.
5. Reinigen Sie die Zubehör mit heißem Wasser, etwas Flüssigwaschmittel und einem nicht scheuernden Schwamm.
6. Sie können die Entfettungsflüssigkeit verwenden, um eventuelle Lebensmittelreste zu entfernen.
7. Gereinigte Teile **MÜSSEN** vor dem Einstecken trocken abgewischt werden.

FEHLERBEHEBUNG

• „ADD“ wird auf dem Bedienfeld angezeigt.

Das Gerät hat das Vorheizen abgeschlossen und Sie können nun Ihre Zutaten hinzufügen.

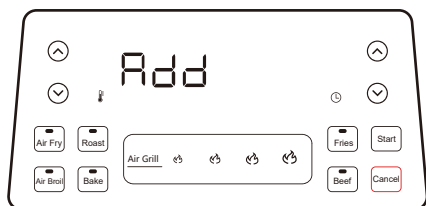

• „E1 oder E2“ wird auf dem Bedienfeld angezeigt

Das Gerät funktioniert nicht richtig. Bitte wenden Sie sich an unseren Kundendienst.



• Wie pausiere ich das Gerät, um mein Essen zu prüfen?

Wenn die Dunstabzugshaube während des Kochens eingeschaltet wird, pausiert das Gerät automatisch. Auf dem Display wird „OPEN“ angezeigt.



• Ist es sicher, den Kochtopf auf meine Arbeitsplatte zu stellen?

Der Topf wird während des Kochens heiß. Vorsichtig handhaben und nur auf eine heiße, sichere Oberfläche stellen.

• Mein Essen ist nicht gar, wenn es fertig gekocht ist.

Um eine gleichmäßige Bräunung zu erreichen, achten Sie darauf, dass die Zutaten gleichmäßig auf dem Boden des Grills verteilt sind und sich nicht überlappen. Schütteln Sie die Zutaten während des Garvorgangs.

• Dauert das Vorheizen zu lange?

Der Grill muss mehr Wärme aufnehmen, um optimal garen zu können, und das Vorheizen kann länger dauern, wenn die Raumtemperatur niedrig ist. Wenn Sie der Meinung sind, dass die Innentemperatur des Topfs hoch genug ist, können Sie die Vorheizphase manuell überspringen.

• Wie kann ich das Vorheizen überspringen?

„PrE“ wird angezeigt, wenn sich das Gerät im Vorheizmodus befindet, halten Sie zu diesem Zeitpunkt die „Start“-Taste 3 Sekunden lang gedrückt, um das Vorheizen zu überspringen. Das Vorheizen kann nur während des Vorheizens übersprungen werden.

• Recyceln Sie dieses Produkt richtig



Das Logo weist darauf hin, dass das Produkt in der gesamten EU nicht mit anderen Haushaltsabfällen entsorgt werden darf. Um zu verhindern, dass eine unkontrollierte Abfallentsorgung die Umwelt oder die menschliche Gesundheit schädigt, sollte das Recycling verantwortungsvoll durchgeführt werden, um die nachhaltige Wiederverwendung von Materialressourcen zu fördern. Verwenden Sie für die Rückgabe von Altgeräten das Rückgabe- und Sammelsystem oder wenden Sie sich an den Händler, bei dem das Produkt gekauft wurde. Sie können dieses Produkt für umweltfreundliches Recycling verwenden.

CONTENU

| | |
|---|----|
| Consignes De Sécurité Importantes | 25 |
| Description Du Produit | 26 |
| Panneau De Contrôle | 27 |
| Frيره À L'air | 28 |
| Rôtir | 29 |
| Air Broil | 30 |
| Cuire Au Four | 31 |
| Frites | 32 |
| Bœuf | 33 |
| Cuire À Gril | 34 |
| Nettoyage | 35 |
| Guide De Dépannage | 36 |

CONSIGNES DE SÉCURITÉ IMPORTANTES

- 1 Cet appareil ne convient pas à l'utilisation par des personnes ayant des capacités physiques, sensorielles ou mentales réduites ou un manque d'expérience et de connaissances (y compris des enfants), à moins que leur utilisation de l'appareil ne soit supervisée ou instruite par une personne responsable de leur sécurité.
- 2 Les enfants doivent être surveillés pour s'assurer qu'ils ne jouent pas avec l'appareil.
- 3 Si le cordon d'alimentation est endommagé, il doit être remplacé par le fabricant, son agent de service ou des personnes de qualification similaire afin d'éviter tout danger.
- 4 Les appareils ne sont pas destinés à être actionnés au moyen d'une minuterie externe ou d'un système de télécommande séparé.
- 5 Gardez l'appareil et son cordon hors de portée des enfants. **NE PAS** laisser l'appareil être utilisé par des enfants. Surveillez étroitement les enfants lorsqu'ils s'approchent de l'appareil.
- 6 Cet appareil est destiné à un usage domestique uniquement. **NE PAS** utiliser cet appareil à d'autres fins que l'utilisation prévue. **NE PAS** utiliser pour le déplacement de véhicules ou de bateaux. **NE PAS** utiliser à l'extérieur. Une mauvaise utilisation peut causer des blessures.
- 7 Lorsque vous utilisez cet appareil, laissez au moins 6 pouces (15,25 cm) d'espace au-dessus et sur **TOUS** les côtés pour la circulation de l'air.
- 8 Utilisez **TOUJOURS** l'ustensile à longue main, le coussin chauffant protecteur ou le gant isolant et utilisez la poignée.
- 9 Assurez-vous que la surface est plane, propre et sèche. **NE PAS** placer l'appareil sur le bord du plan de travail pendant le fonctionnement. Assurez-vous **TOUJOURS** que l'appareil est correctement assemblé avant l'utilisation.
- 10 **NE PAS** installer d'objets sur l'appareil.
- 11 **NE PAS** utiliser l'appareil à d'autres fins que celles décrites dans ce manuel.
- 12 Placez **TOUS** les ingrédients dans des paniers pour éviter tout contact avec les éléments chauffants de l'appareil. **NE PAS** remplir trop le panier car les ingrédients peuvent devenir plus gros lorsqu'ils sont chauffés.
- 13 Pour éviter les chocs électriques. **NE PAS** immerger les cordons, la prise électrique ou le compartiment de votre friteuse à air dans de l'eau ou un liquide.
- 14 Pendant l'utilisation, **NE PAS** toucher le bord de la marmite de cuisson, la coque extérieure, la poignée du bac à cuisson, la poignée du gril et la surface du couvercle supérieure pour éviter les brûlures.
- 15 **AVERTISSEMENT**: Surfaces chaudes.
Attention : Avant la première utilisation, retirez **TOUS** les autocollants promotionnels et les matériaux d'emballage, et nettoyez de la marmite de cuisson, le couvercle supérieur, etc. sur la machine.
- 16 Pendant et après la cuisson, le bac à cuisson et la plaque à griller sont très chauds et ne peuvent pas être touchés directement à la main. Veuillez utiliser les gants de cuisine pour ramasser et placer le bac à cuisson et la plaque à griller.
- 17 Pendant le bac à cuisson chaud, la vapeur chaude est libérée par les sorties d'air. Maintenez vos mains et votre visage à bonne distance de la vapeur et des sorties d'air. Faites également attention à la vapeur et à l'air chauds lorsque vous retirez la marmite des appareils.
- 18 Pour déconnecter, mettez l'appareil sur "OFF" (fermer), puis débranchez-le de la prise lorsqu'il n'est pas utilisé et avant de le nettoyer.



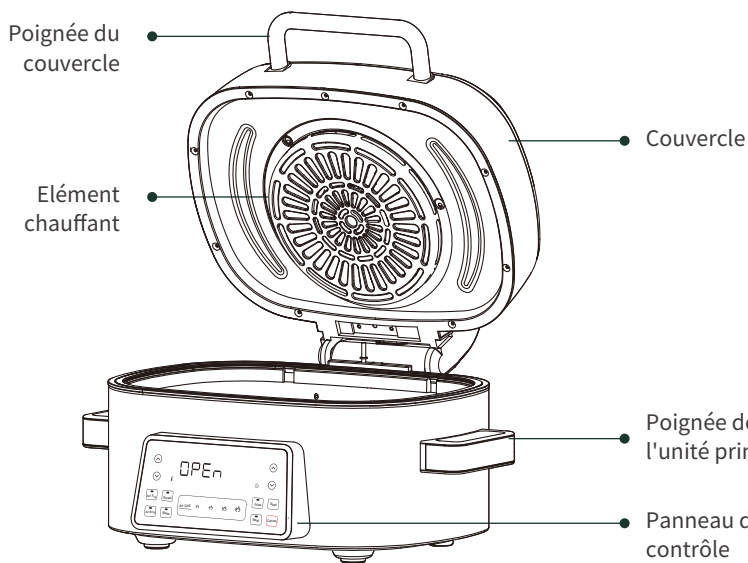
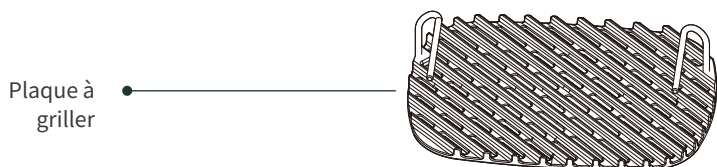
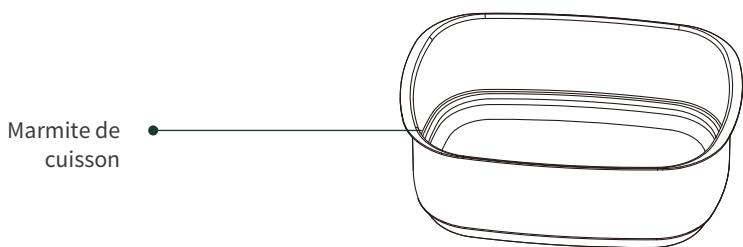







DESCRIPTION DU PRODUIT



PANNEAU DE CONTRÔLE



Description de l'opération:

| | |
|--|--|
| <p> Appuyez sur ce bouton pour augmenter la température.</p> <p> Appuyez sur ce bouton pour abaisser la température.</p> | <p> Appuyez sur ce bouton pour sélectionner la fonction Frites.</p> <p><u>Air Grill</u> Appuyez sur ce bouton pour sélectionner la fonction Cuire à grill (faible, moyen, élevé, maximum).</p> |
| <p> Appuyez sur ce bouton pour augmenter le temps.</p> <p> Appuyez sur ce bouton pour raccourcir le temps.</p> | <p> Appuyez sur ce bouton pour sélectionner la fonction Rôtir.</p> <p> Appuyez sur ce bouton pour sélectionner la fonction Cuire au four.</p> |
| <p> Appuyez sur ce bouton pour commencer la cuisson.</p> | <p> Appuyez sur ce bouton pour la fonction Air Broil.</p> |
| <p> Appuyez sur ce bouton pour annuler la cuisson.</p> | <p> Appuyez sur ce bouton pour la fonction Frire à l'air.</p> |

FRIRE À L'AIR

1. Appuyez sur le bouton "Air Fry" pour afficher la température et l'heure par défaut.



2. Appuyez sur les flèches vers le haut ou vers le bas pour régler la température et l'heure.



3. Appuyez sur le bouton "Start" pour démarrer le préchauffage et "PrE" apparaîtra sur l'écran.

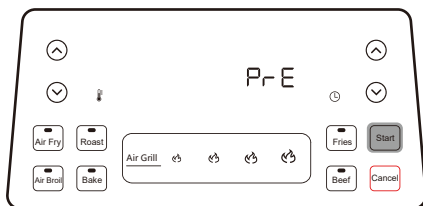

4. Une fois le préchauffage terminé, "Add" s'affiche, ouvrez le couvercle, l'appareil cesse de fonctionner et "OPEn" apparaît sur l'écran.

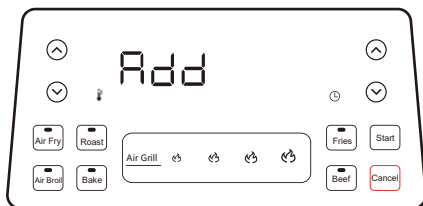

5. Ajoutez le bac à cuisson et les ingrédients, fermez le couvercle et la machine décomptera automatiquement.

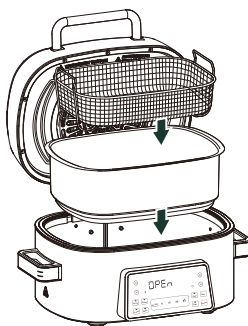

6. Une fois le compte à rebours terminé, "donE" clignote à l'écran.



7. Appuyez sur le bouton "Cancel" pour entrer en mode veille et "OFF" apparaît sur l'écran.

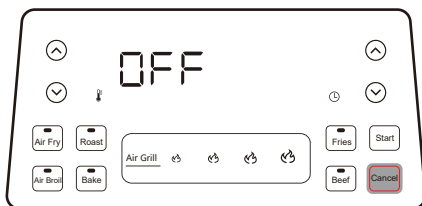

RÔTIR

1. Appuyez sur le bouton **"Roast"** pour afficher la température et l'heure par défaut.

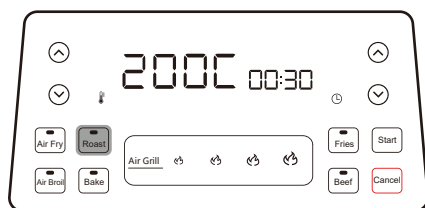

2. Appuyez sur les flèches vers le haut ou vers le bas pour régler la température et l'heure.



3. Appuyez sur le bouton **"Start"** pour démarrer le préchauffage et "PrE" apparaîtra sur l'écran.

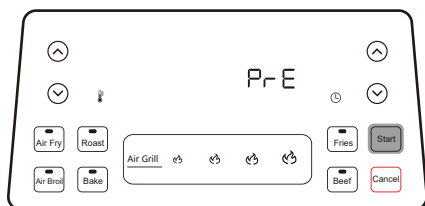

4. Une fois le préchauffage terminé, "Add" s'affiche, ouvrez le couvercle, l'appareil cesse de fonctionner et "OPEN" apparaît sur l'écran.

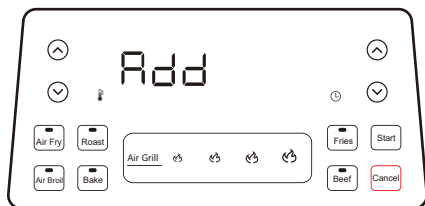

5. Ajoutez le bac à cuisson et les ingrédients, fermez le couvercle et la machine décomptera automatiquement.

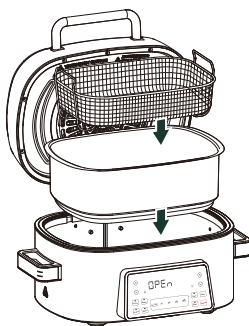

6. Une fois le compte à rebours terminé, "done" clignote à l'écran.



7. Appuyez sur le bouton **"Cancel"** pour entrer en mode veille et "OFF" apparaît sur l'écran.

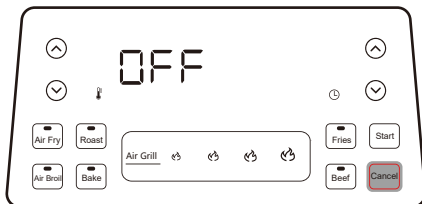

AIR BROIL

1. Appuyez sur le bouton "Air Broil" pour afficher la température et l'heure par défaut.

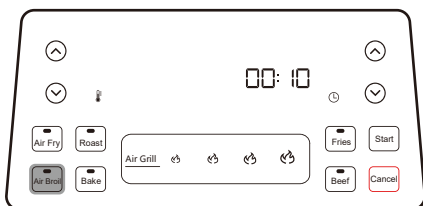

2. Appuyez sur les flèches vers le haut ou vers le bas pour régler la température et l'heure.



3. Appuyez sur le bouton "Start" pour démarrer le préchauffage et "PrE" apparaîtra sur l'écran.

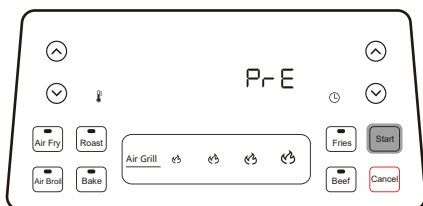

4. Une fois le préchauffage terminé, "Add" s'affiche, ouvrez le couvercle, l'appareil cesse de fonctionner et "Open" apparaît sur l'écran.



5. Ajoutez le bac à cuisson et les ingrédients, fermez le couvercle et la machine décomptera automatiquement.

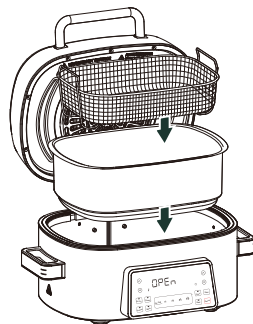

6. Une fois le compte à rebours terminé, "donE" clignote à l'écran.



7. Appuyez sur le bouton "Cancel" pour entrer en mode veille et "OFF" apparaît sur l'écran.

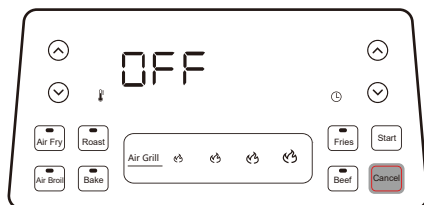

CUIRE AU FOUR

1. Appuyez sur le bouton **"Bake"** pour afficher la température et l'heure par défaut.



2. Appuyez sur les flèches vers le haut ou vers le bas pour régler la température et l'heure.



3. Appuyez sur le bouton **"Start"** pour démarrer le préchauffage et "PrE" apparaîtra sur l'écran.

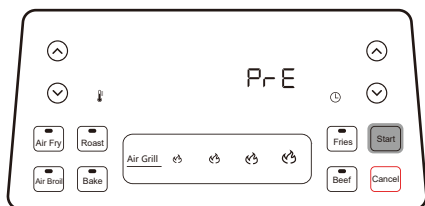

4. Une fois le préchauffage terminé, "Add" s'affiche, ouvrez le couvercle, l'appareil cesse de fonctionner et "OPEn" apparaît sur l'écran.



5. Ajoutez le bac à cuisson et les ingrédients, fermez le couvercle et la machine décomptera automatiquement.

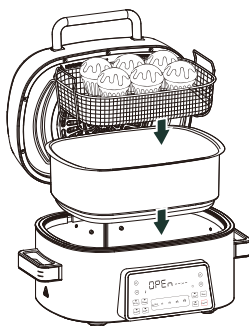

6. Une fois le compte à rebours terminé, "donE" clignote à l'écran.



7. Appuyez sur le bouton **"Cancel"** pour entrer en mode veille et "OFF" apparaît sur l'écran.

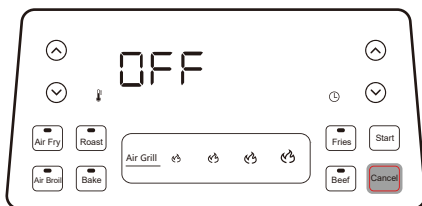

FRITES

1. Appuyez sur le bouton "Fries" pour afficher la température et l'heure par défaut.

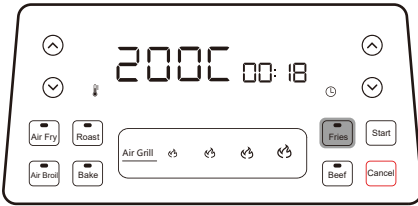

2. Appuyez sur les flèches vers le haut ou vers le bas pour régler la température et l'heure.



3. Appuyez sur le bouton "Start" pour démarrer le préchauffage et "PrE" apparaîtra sur l'écran.

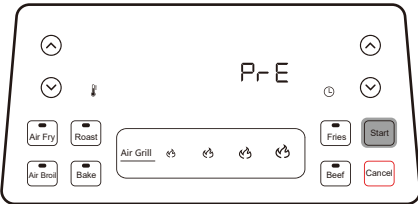

4. Une fois le préchauffage terminé, "Add" s'affiche, ouvrez le couvercle, l'appareil cesse de fonctionner et "OPEn" apparaît sur l'écran.



5. Ajoutez le bac à cuisson et les ingrédients, fermez le couvercle et la machine décomptera automatiquement.

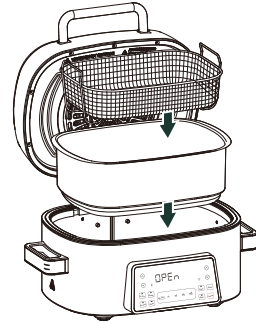

6. Une fois le compte à rebours terminé, "donE" clignote à l'écran.



7. Appuyez sur le bouton "Cancel" pour entrer en mode veille et "OFF" apparaît sur l'écran.



Remarque: Pour obtenir les meilleurs résultats de cuisson, nous vous recommandons de secouer les ingrédients pendant le processus de cuisson.

Lorsque vous ouvrez le couvercle, l'appareil s'arrête automatiquement et "OPEn" s'affiche sur l'écran. Utilisez le gant de cuisine pour secouer le panier à friture. Lorsque le panier est remis et que le couvercle est fermé, la cuisson reprend.

BŒUF

1. Appuyez sur le bouton **"Beef"** pour afficher la température et l'heure par défaut.



2. Ajoutez la plaque à griller dans la marmite de cuisson.

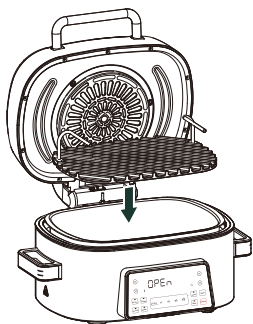

3. Appuyez sur les flèches vers le haut ou vers le bas pour régler la température et l'heure.



4. Appuyez sur le bouton **"Start"** pour démarrer le préchauffage et "PrE" apparaîtra sur l'écran.

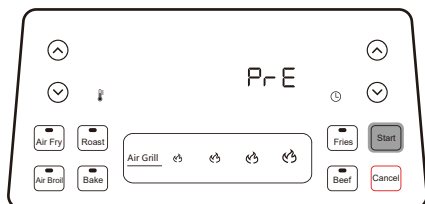

5. Une fois le préchauffage terminé, "Add" s'affiche, ouvrez le couvercle, l'appareil cesse de fonctionner et "OPEN" apparaît sur l'écran.

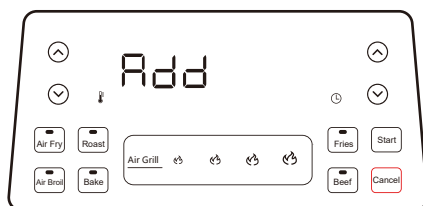

6. Placez les ingrédients sur la plaque à griller, fermez le couvercle et l'appareil démarre automatiquement la cuisson.

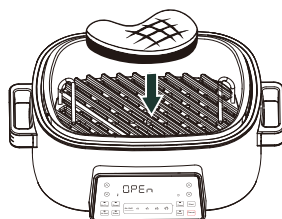

7. Une fois le compte à rebours terminé, "done" clignote à l'écran.



8. Appuyez sur le bouton **"Cancel"** pour entrer en mode veille et "OFF" apparaît sur l'écran.



CUIRE À GRIL

| Fonction | Acquiescement | Ecart de température | Limite de temps |
|---------------------|----------------|----------------------|----------------------|
| Air Grill (faible) | 200°C 00:15 | / | 1-30min 1min/step |
| Air Grill (moyen) | 220°C 00:15 | / | |
| Air Grill (élevé) | 240°C 00:15 | / | |
| Air Grill (maximum) | 265°C 00:10 | / | |

1. Appuyez sur le bouton "🔥" pour afficher la température et l'heure par défaut.

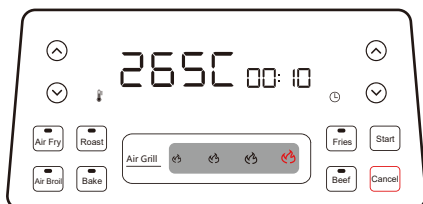

2. Placez la plaque à griller dans la marmite de cuisson.

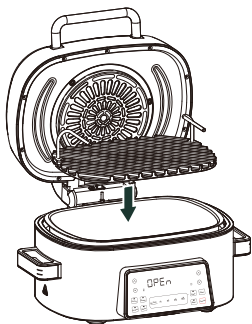

3. Appuyez sur le bouton "Start" pour démarrer le préchauffage et "PrE" apparaîtra sur l'écran.



4. Une fois le préchauffage terminé, "Add" s'affiche, ouvrez le couvercle, l'appareil cesse de fonctionner et "OPEn" apparaît sur l'écran.

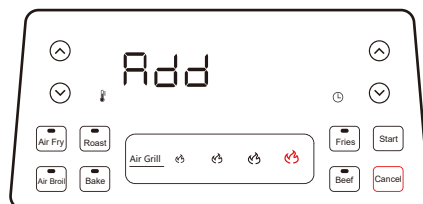

5. Placez les ingrédients sur la plaque à griller, fermez le couvercle et l'appareil démarre automatiquement la cuisson.

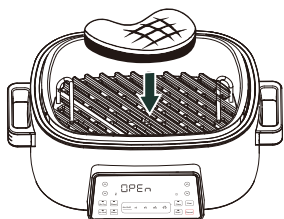

6. Une fois le compte à rebours terminé, "donE" clignote à l'écran.



7. Appuyez sur le bouton "Cancel" pour entrer en mode veille et "OFF" apparaît sur l'écran.

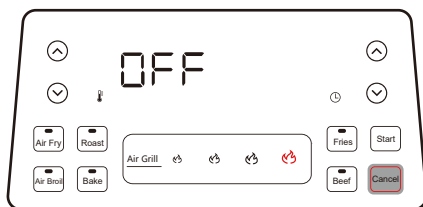

Remarque: pendant la cuisson, vous pouvez ouvrir le couvercle pour vérifier les aliments ou les retourner ; l'appareil s'arrête automatiquement lorsque le couvercle est ouvert et poursuit la cuisson lorsqu'il est fermé.

NETTOYAGE

Laissez **TOUJOURS** l'appareil refroidir avant de le nettoyer.

- Débranchez l'appareil de la prise murale avant de le nettoyer. Laissez le couvercle ouvert une fois la cuisson terminée pour qu'il refroidisse plus rapidement.
- Retirez les accessoires et laissez l'appareil refroidir avant de la nettoyer.
- L'appareil devrait être nettoyé complètement après **CHAQUE** utilisation.
N'utilisez pas d'ustensiles de cuisine en métal ou de produits de nettoyage abrasifs pour nettoyer les accessoires et l'intérieur d'appareil, cela pourrait endommager le revêtement.
- Pour nettoyer l'unité principale et le panneau de contrôle, essayez-les soigneusement avec un chiffon humide.
- Nettoyez les accessoires avec de l'eau chaude, du détergent liquide et l'éponge non abrasive.
- Vous pouvez utiliser le liquide dégraissant pour éliminer les résidus alimentaires restants.
- Les pièces nettoyées doivent être essuyées avant d'être branchées.

GUIDE DE DÉPANNAGE

- **"Add"** (ajoutez) apparaît sur l'écran du panneau de commande.

L'appareil a fini de préchauffer et il est maintenant temps d'ajouter les ingrédients.

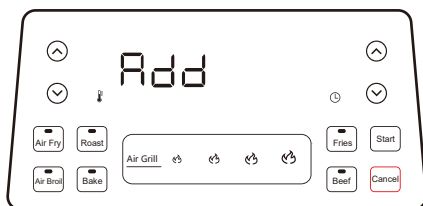

- **"E1 ou E2"** apparaît à l'écran.

L'appareil ne fonctionne pas bien. Veuillez communiquer avec le service après-vente.



- **Comment puis-je mettre l'appareil en pause afin de vérifier mes aliments?**

Lorsque le couvercle est ouverte pendant la cuisson, l'appareil se met automatiquement en pause. L'écran affiche "OPEn"(ouvert).



- **Est-il sécuritaire de mettre une marmite sur mon comptoir?**

La marmite deviendra chaude pendant la cuisson. Manipulez avec soin et placez uniquement sur des surfaces résistantes à la chaleur.

- **Ma nourriture n'est pas cuite alors que la cuisson est terminée.**

Pour dorer les aliments uniformément, assurez-vous que les ingrédients sont disposés en une couche uniforme au fond du gril, sans chevauchement. Secouez les ingrédients en vrac pendant le processus de cuisson pour maintenir un croustillant uniforme.

- **Le préchauffage est trop long ?**

Le gril doit absorber plus de chaleur pour une cuisson optimale et peut prendre plus de temps à préchauffer lorsque la température ambiante est basse. Si vous jugez que la température interne de la marmite est suffisamment élevée, vous pouvez sauter l'étape du préchauffage manuellement.

- **Comment puis-je annuler le préchauffage?**

Lorsque l'appareil est en mode préchauffage, "PrE" s'affiche, appuyez sur le bouton "Start" pendant 3 secondes pour sauter le préchauffage. Le préchauffage ne peut être sauté que pendant le préchauffage.

- **Recyclez ce produit correctement**

 Ce marquage indique que ce produit ne doit pas être jeté avec d'autres déchets ménagers dans toute l'UE. Pour prévenir d'éventuels dommages sur l'environnement ou la santé résultant de la décharge non contrôlée des déchets, recycler l'appareil de manière responsable afin de favoriser la réutilisation rationnelle des matériaux. Pour renvoyer votre appareil usagé, utiliser les systèmes de retour et de collecte ou contacter le détaillant chez qui ce produit a été acheté. Ceux-ci peuvent procéder au recyclage du produit en toute sécurité.

CONTENUTO

| | |
|------------------------------------|----|
| Importanti Istruzioni di Sicurezza | 37 |
| Descrizione dei Pezzi | 38 |
| Pannello di Controllo | 39 |
| Friggere ad Aria | 40 |
| Arrosto | 41 |
| Air Broil | 42 |
| Bake | 43 |
| Frittura | 44 |
| Manzo | 45 |
| Griglia ad Aria | 46 |
| Pulizia | 47 |
| Risoluzione dei Problemi | 48 |

IMPORTANTI ISTRUZIONI DI SICUREZZA

- 1 Questo apparecchio non è destinato all'uso da parte di persone (compresi i bambini) con ridotte capacità fisiche, sensoriali o mentali, o con mancanza di esperienza e conoscenza, a meno che non abbiano ricevuto supervisione o istruzioni sull'uso dell'apparecchio da parte di una persona responsabile della loro sicurezza.
- 2 I bambini devono essere sorvegliati per evitare che giochino con l'apparecchio.
- 3 Se il cavo di corrente è danneggiato, **DEVE** essere sostituito dal produttore, dal suo agente di assistenza o da persone analogamente qualificate, al fine di evitare un pericolo.
- 4 L'apparecchio **NON PUÒ** essere comandato tramite un timer esterno o un sistema di controllo remoto separato.
- 5 Tenere l'apparecchio e il suo cavo fuori dalla portata dei bambini. **NON** permettere che l'apparecchio venga utilizzato dai bambini. In caso di utilizzo in prossimità di bambini, è necessaria una stretta sorveglianza.
- 6 Questo apparecchio è solo per l'uso domestico. **NON** utilizzare l'apparecchio per scopi diversi da quelli previsti. **NON** utilizzare in veicoli o imbarcazioni in movimento. **NON** utilizzare all'aperto. L'uso improprio può causare lesioni.
- 7 Quando si utilizza questo apparecchio, prevedere almeno 6 pollici (15,25cm) di spazio sopra e su tutti i lati per la circolazione dell'aria.
- 8 Usare sempre utensili a manico lungo, cuscinetti termici protettivi o guanti da forno isolati e utilizzare le maniglie.
- 9 Assicurarsi che la superficie sia piana, pulita e asciutta. **NON** appoggiare l'apparecchio sul bordo del piano di lavoro durante il funzionamento. Assicurarsi **SEMPRE** che l'apparecchio sia correttamente assemblato prima dell'uso.
- 10 Non mettere nulla sopra l'apparecchio.
- 11 Non utilizzare l'apparecchio per scopi **DIVERSI** da quelli descritti nel manuale.
- 12 Tenere tutti gli ingredienti nel cestino per evitare il contatto con gli elementi riscaldanti dell'apparecchio. Poiché gli ingredienti possono ingrossarsi dopo il riscaldamento, non riempire eccessivamente il cestello.
- 13 Per evitare le scosse elettriche. **NON** immergere il cavo, le spine o l'alloggiamento di un apparecchio principale in acqua o altri liquidi.
- 14 Durante l'uso, non toccare il margine interno della pentola, il corpo esterno, il manico del cestello per arrostiti, il manico della griglia e la superficie del coperchio superiore per evitare scottature.
- 15 **ATTENZIONE:** Superfici calde.
NOTA: prima del primo utilizzo, rimuovere tutti gli adesivi promozionali e il materiale di imballaggio e pulire il vaso interno, il coperchio superiore e le altre parti della macchina.
- 16 Durante e dopo la cottura, il cestello dell'arrosto e la griglia sono molto caldi e non possono essere toccati direttamente con le mani. Utilizzare i guanti da forno per prendere e posizionare il cestello dell'arrosto e la griglia.
- 17 Durante la frittura ad aria calda, dalle uscite dell'aria fuoriesce vapore caldo. Tenere mani e viso a distanza di sicurezza dal vapore e dalle uscite dell'aria. Fare attenzione al vapore e all'aria calda anche quando si toglie la padella dall'apparecchio.
- 18 Per spegnere l'apparecchio, ruotarlo su "OFF", poi staccare la spina dalla presa di corrente quando non è utilizzato e prima della pulizia.



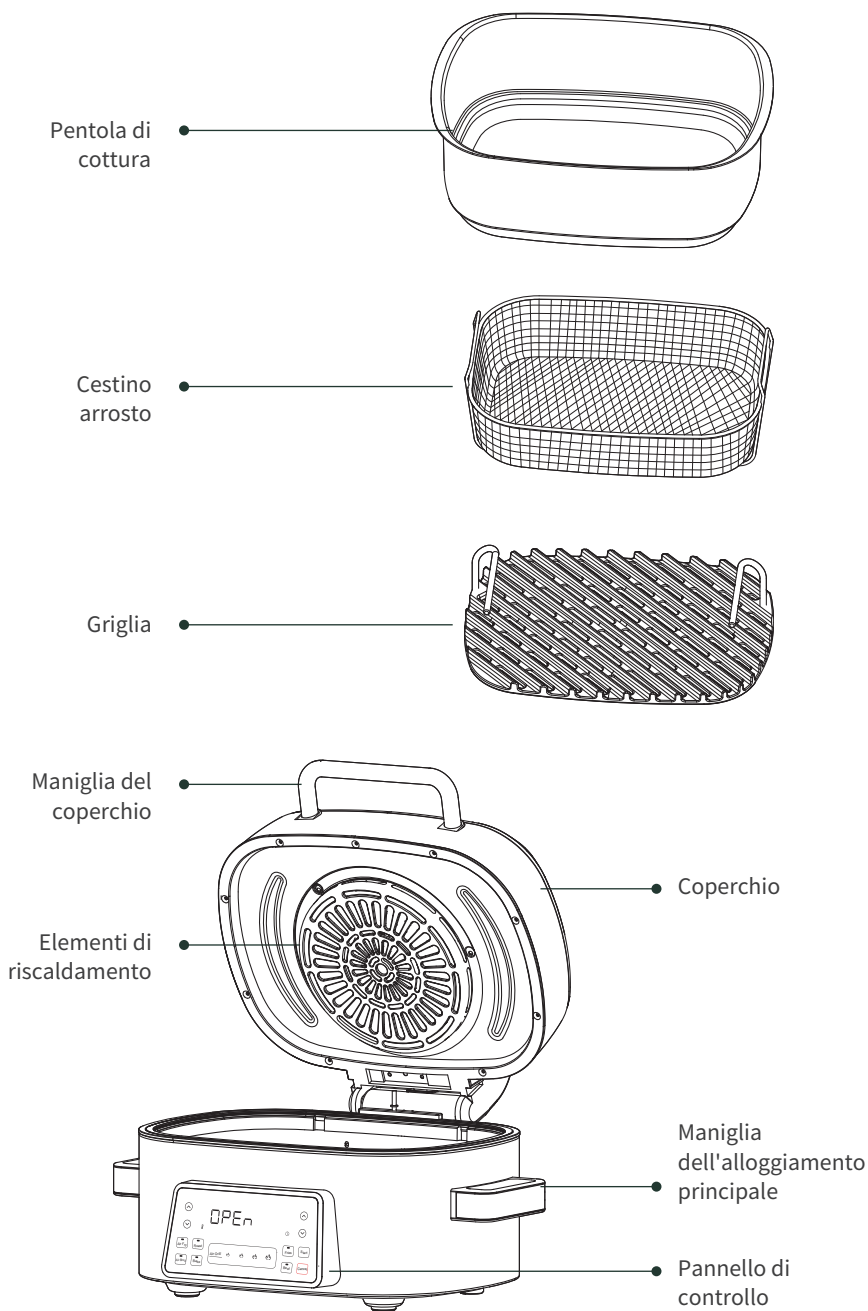









DESCRIZIONE DEI PEZZI



PANNELLO DI CONTROLLO



Presentazione dell'operazione:

| | |
|---|--|
| <p> premere per diminuire la temperatura.</p> <p> premere per aumentare la temperatura.</p> | <p> premere per scegliere la funzione Fries.</p> |
| <p> premere per aumentare il tempo.</p> <p> premere per diminuire il tempo.</p> | <p><u>Air Grill</u>  premere per scegliere la funzione Friggere ad Aria (Bassa, Media, Alta, Massima).</p> <p> premere per scegliere la funzione Roast.</p> <p> premere per scegliere la funzione Bake.</p> |
| <p> premere per iniziare la cottura.</p> | <p> premere per scegliere la funzione Air Broil</p> |
| <p> premere per annullare la cottura.</p> | <p> premere per scegliere la funzione Griglia ad Aria.</p> |

FRIGGERE AD ARIA

1. Premere il pulsante "Air Fry", per mostrare la temperatura e l'ora predefinite.



2. Premere il pulsante regolare la temperatura e l'ora.



3. Premere il pulsante "Start", per iniziare il preriscaldamento, sul display appare "PrE".

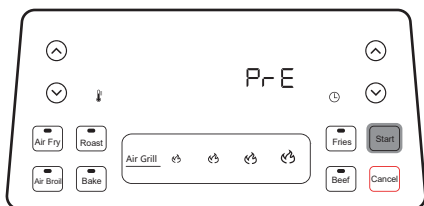

4. Quando il preriscaldamento è terminato, sul display appare la scritta "Add", mentre aprendo il coperchio dell' apparecchio si smette di lavorare e sul display appare la scritta "OPEn".



5. Aggiungere il cestino arrosto e gli ingredienti, chiudere il coperchio e l'apparecchio inizierà automaticamente il conto alla rovescia.

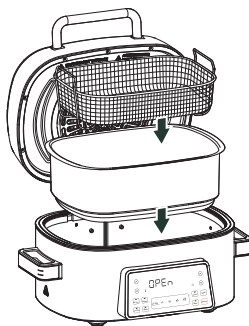

6. Quando il conto alla rovescia è terminato, sul display lampeggia "donE".



7. Premere il pulsante "Cancel", per passare alla modalità standby; sul display appare "OFF".

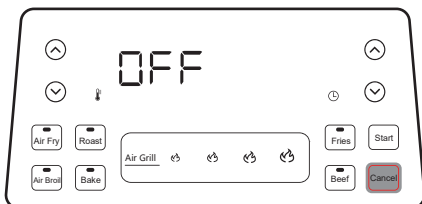

ARROSTO

1. Premere il pulsante "**Roast**", per mostrare la temperatura e l'ora predefinite.



2. Premere il pulsante regolare la temperatura e l'ora.



3. Premere il pulsante "**Start**", per iniziare il preriscaldamento, sul display appare "PrE".

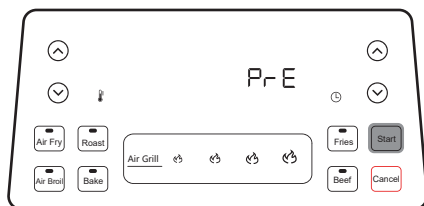

4. Quando il preriscaldamento è terminato, sul display appare la scritta "Add", mentre aprendo il coperchio dell'apparecchio si smette di lavorare e sul display appare la scritta "OPEN".



5. Aggiungere il cestino arrosto e gli ingredienti, chiudere il coperchio e l'apparecchio inizierà automaticamente il conto alla rovescia.

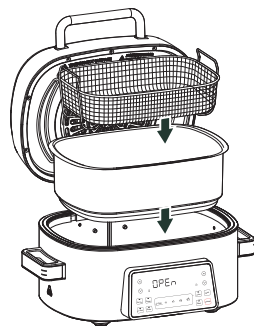

6. Quando il conto alla rovescia è terminato, sul display lampeggia "donE".



7. Premere il pulsante "**Cancel**", per passare alla modalità standby; sul display appare "OFF".

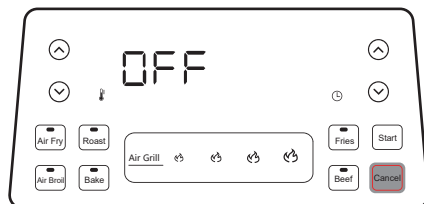

AIR BROIL

1. Premere il pulsante "Air Broil", per mostrare la temperatura e l'ora predefinite.

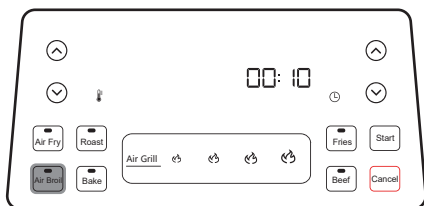

2. Premere il pulsante regolare la temperatura e l'ora..

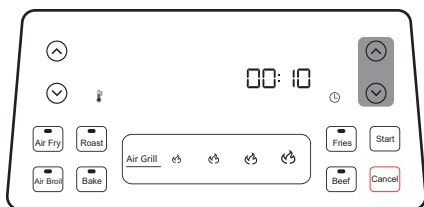

3. Premere il pulsante "Start", per iniziare il preriscaldamento, sul display appare "PrE".

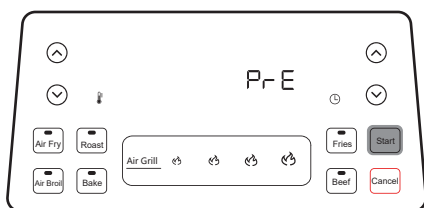

4. Quando il preriscaldamento è terminato, sul display appare la scritta "Add", mentre aprendo il coperchio dell' apparecchio si smette di lavorare e sul display appare la scritta "OPEn".



5. Aggiungere il cestino arrosto e gli ingredienti, chiudere il coperchio e l'apparecchio inizierà automaticamente il conto alla rovescia.

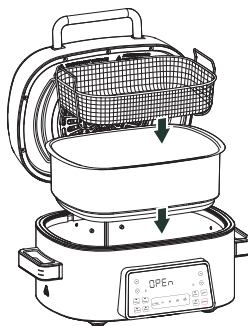

6. Quando il conto alla rovescia è terminato, sul display lampeggia "donE".



7. Premere il pulsante "Cancel", per passare alla modalità standby; sul display appare "OFF".

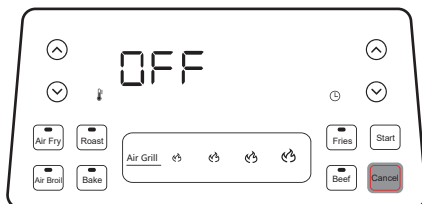

BAKE

1. Premere il pulsante **"Bake"**, per mostrare la temperatura e l'ora predefinite.



2. Premere il pulsante regolare la temperatura e l'ora.



3. Premere il pulsante **"Start"**, per iniziare il preriscaldamento, sul display appare "PrE".

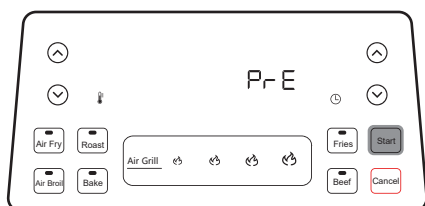

4. Quando il preriscaldamento è terminato, sul display appare la scritta "Add", mentre aprendo il coperchio dell' apparecchio si smette di lavorare e sul display appare la scritta "OPEn".



5. Aggiungere il cestino arrosto e gli ingredienti, chiudere il coperchio e l'apparecchio inizierà automaticamente il conto alla rovescia.

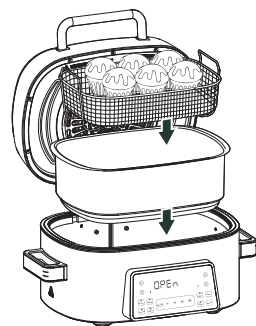

6. Quando il conto alla rovescia è terminato, sul display lampeggia "donE".



7. Premere il pulsante **"Cancel"**, per passare alla modalità standby; sul display appare "OFF".

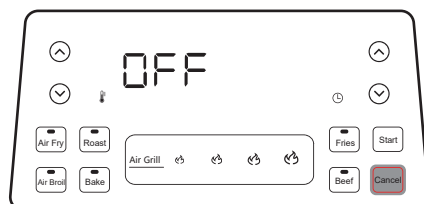

FRITTURA

1. Premere il pulsante "Fries", per mostrare la temperatura e l'ora predefinite.

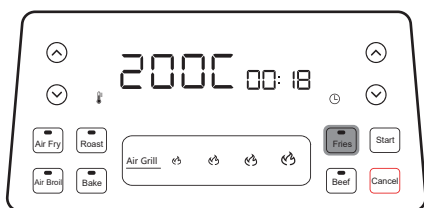

2. Premere il pulsante regolare la temperatura e l'ora.



3. Premere il pulsante "Start", per iniziare il preriscaldamento, sul display appare "PrE".

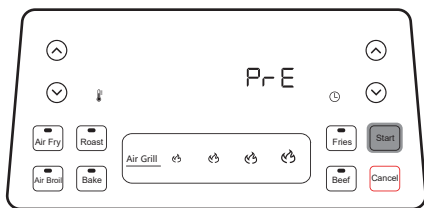

4. Quando il preriscaldamento è terminato, sul display appare la scritta "Add", mentre aprendo il coperchio dell'apparecchio si smette di lavorare e sul display appare la scritta "OPEn".



5. Aggiungere il cestino arrosto e gli ingredienti, chiudere il coperchio e l'apparecchio inizierà automaticamente il conto alla rovescia.

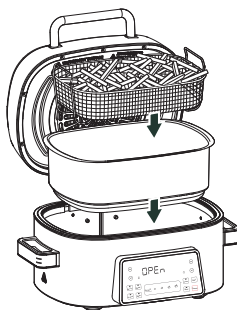

6. Quando il conto alla rovescia è terminato, sul display lampeggia "donE".



7. Premere il pulsante "Cancel", per passare alla modalità standby; sul display appare "OFF".

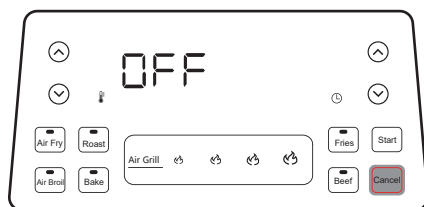

Nota: per ottenere un risultato ottimale, si consiglia di scuotere gli ingredienti durante la cottura.

Quando si apre il coperchio, l'apparecchio si arresta automaticamente e sul display appare "OPEn". Utilizzare i guanti da forno per scuotere il cestino. Quando si rimette il cestino e si chiude il coperchio, la cottura riprende.

MANZO

1. Premere il pulsante **"Beef"**, per mostrare la temperatura e l'ora predefinite.



2. Aggiungere la griglia alla pentola.

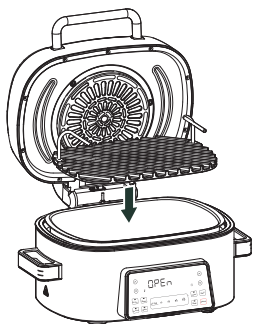

3. Premere il pulsante regolare la temperatura e l'ora.



4. Premere il pulsante **"Start"**, per iniziare il preriscaldamento, sul display appare **"PrE"**.

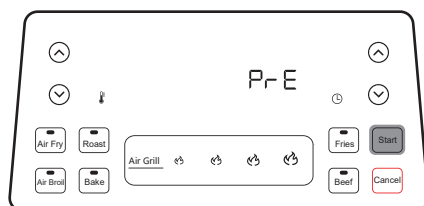

5. Quando il preriscaldamento è terminato, sul display appare la scritta **"Add"**, mentre aprendo il coperchio dell'apparecchio si smette di lavorare e sul display appare la scritta **"OPEn"**.



6. Aggiungere l'ingrediente sulla griglia, chiudere il coperchio e l'apparecchio inizierà a cuocere automaticamente.

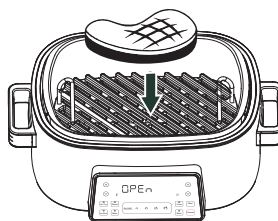

7. Quando il conto alla rovescia è terminato, sul display lampeggia **"donE"**.



8. Premere il pulsante **"Cancel"**, per passare alla modalità standby; sul display appare **"OFF"**.

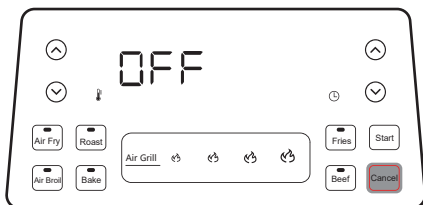

GRIGLIA AD ARIA

| Fusione | Predefinito | Intervallo di temperatura | Intervallo di tempo |
|---------------------------|----------------|---------------------------|-----------------------|
| Griglia ad aria (bassa) | 200°C 00:15 | / | 1-30min 1min/passò |
| Griglia ad aria (media) | 220°C 00:15 | / | |
| Griglia ad aria (alta) | 240°C 00:15 | / | |
| Griglia ad aria (massima) | 265°C 00:10 | / | |

1. Premere il pulsante "🔥", per selezionare la modalità desiderata della griglia ad aria. per mostrare l'ora e la temperatura predefinite.

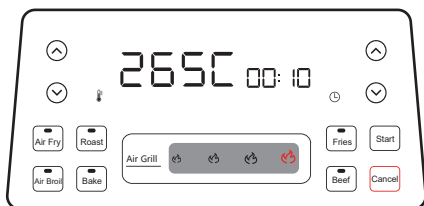

2. Aggiungere la griglia nella pentola.

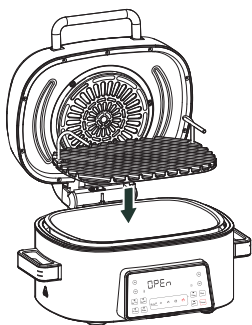

3. Premere il pulsante regolare il tempo. Premere il pulsante "Start", per iniziare il preriscaldamento; sul display appare "PrE".



4. Quando il preriscaldamento è terminato, sul display appare "Add", mentre aprendo il coperchio dell'apparecchio si smette di lavorare e sul display appare "OPEN".

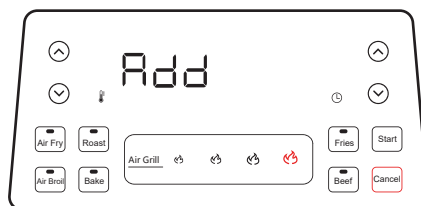

5. Aggiungere l'ingrediente sulla griglia, chiudere il coperchio e l'apparecchio inizierà a cuocere automaticamente.

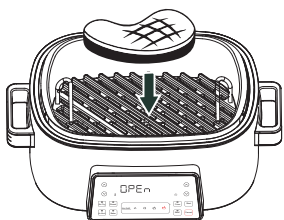

6. Quando il conto alla rovescia è terminato, sul display lampeggia "done".



7. Premere il pulsante "Cancel", per passare alla modalità standby; sul display appare "OFF".



Nota: durante la cottura, è possibile aprire il coperchio per controllare il cibo o girarlo; l'apparecchio si mette automaticamente in pausa quando il coperchio viene aperto, quindi riprende la cottura quando il coperchio viene chiuso.

PULIZIA

Prima della pulizia, lasciare sempre raffreddare l'apparecchio.

Prima della pulizia, Staccare l'apparecchio dalla presa di corrente.

1. Staccare la spina dalla presa di corrente e lasciare raffreddare l'apparecchio per almeno 30 minuti.
2. Rimuovere gli accessori per lasciare raffreddare la friggitrice ad aria prima di pulirla.
3. Pulire l'apparecchio dopo ogni utilizzo. Non pulire gli accessori e l'interno dell'apparecchio con utensili da cucina metallici o materiali abrasivi per non danneggiare il rivestimento.
4. Pulire l'esterno dell'apparecchio con un panno umido.
5. Pulire gli accessori con acqua calda, un po' di detersivo liquido e una spugna non abrasiva.
6. È possibile rimuovere eventuali resti di cibo con un liquido sgrassante.
7. Le parti pulite devono essere asciugate prima di collegarle.

RISOLUZIONE DEI PROBLEMI

- Sul display del pannello di controllo appare "Add".

Il preriscaldamento del dispositivo è stato completato ed è ora di aggiungere gli ingredienti.



- Sul display appare E1 o E2.

Il dispositivo non funziona correttamente. Contattare il servizio post-vendita.



- Come si fa a mettere in pausa l'apparecchio per controllare gli alimenti?

Quando il coperchio è aperto durante una funzione di cottura, l'apparecchio si mette automaticamente in pausa. Il display mostra "OPEn".



- È sicuro mettere la pentola di cottura sul mio piano di lavoro?

La pentola si riscalda durante la cottura. Fare attenzione quando la si maneggia e posizionarla solo su superfici sicure dal punto di vista termico.

- Il mio cibo non si è cotto durante la cottura all'aria.

Per ottenere una doratura uniforme, assicurarsi che gli ingredienti siano disposti in uno strato uniforme sul fondo della griglia dell'arrosto, senza sovrapposizioni. Scuotere gli ingredienti durante la cottura per ottenere una consistenza croccante.

- Il tempo di preriscaldamento è troppo lungo?

La griglia deve assorbire più calore per ottenere risultati di cottura ottimali e può richiedere più tempo per il preriscaldamento a basse temperature ambiente, quindi se ritieni che la temperatura interna della padella sia sufficientemente alta, puoi saltare il preriscaldamento in modo manuale.

- Come si fa a saltare il preriscaldamento?

Mentre l'apparecchio è in modalità di preriscaldamento, viene visualizzato "PrE", tenere premuto il pulsante "Start" per 3 secondi per saltare il preriscaldamento. Il preriscaldamento può essere saltato solo durante il preriscaldamento.

- Riciclare correttamente questo prodotto.



Il marchio indica che il prodotto non può essere smaltito con altri rifiuti domestici in tutta l'UE. Per evitare che lo smaltimento incontrollato dei rifiuti danneggi l'ambiente o la salute umana, il riciclaggio deve essere effettuato in modo responsabile per promuovere il riutilizzo sostenibile delle risorse materiali. Per restituire un vecchio dispositivo, utilizzare il sistema di restituzione e raccolta, contattare il rivenditore che ha acquistato il prodotto. In questo modo, il prodotto potrà essere riciclato in modo sicuro per l'ambiente.

ÍNDICE

| | |
|--|----|
| Instrucciones de seguridad importantes | 49 |
| Descripción de piezas | 50 |
| Panel de control | 51 |
| Freír con aire | 52 |
| Tostar | 53 |
| Asar con air | 54 |
| Hornear | 55 |
| Patatas fritas | 56 |
| Carne de res | 57 |
| Parrilla de aire | 58 |
| Limpieza | 59 |
| Resolución de problemas | 60 |

INSTRUCCIONES DE SEGURIDAD IMPORTANTES

- 1 Este aparato no pueden utilizarlo personas (los niños incluidos) con facultades físicas, sensoriales o intelectuales disminuidas, o que carezcan de la experiencia y los conocimientos debidos, siempre que sea bajo supervisión y si han recibido instrucciones para utilizar el aparato por parte de una persona responsable de su seguridad.
- 2 Los niños deben ser supervisados para asegurarse de que no jueguen con el aparato.
- 3 Si el cable de alimentación está dañado, **DEBE** ser reemplazado por el fabricante, su agente de servicio o personas con calificaciones similares para evitar un peligro.
- 4 **NO** conecte nunca este aparato a un interruptor con temporizador externo o a un sistema de control remoto independiente.
- 5 Mantenga el aparato y su cable fuera del alcance de los niños. **NO** permita que los niños utilicen el aparato. Extreme la supervisión cuando utilice el aparato cerca de los niños.
- 6 Este aparato está destinado **ÚNICAMENTE** a uso doméstico. **NO** emplee el aparato para fines distintos a los que está destinado. **NO** lo utilice en vehículos o embarcaciones que estén en marcha. **NO** lo utilice a la intemperie. El uso indebido del mismo podría ocasionar lesiones.
- 7 Al utilizar este aparato, disponga de espacio adecuado por encima y alrededor de este (al menos, 15,25 cm) para permitir la circulación del aire.
- 8 **SIEMPRE** use utensilios de mango largo, almohadillas térmicas protectoras o guantes aislados para horno, y use las manijas.
- 9 Asegúrese de que la superficie esté nivelada, limpia y seca. **NO** coloque el aparato cerca del borde de la encimera durante su funcionamiento.
- 10 No coloque nada encima del aparato.
- 11 No utilice el aparato para **NINGÚN** otro propósito que no sea el descrito en este manual.
- 12 Mantenga todos los ingredientes en la cesta para evitar **CUALQUIER** contacto con los elementos calefactores del aparato. Dado que los ingredientes pueden agrandarse después de calentarlos, no llene demasiado la cesta.
- 13 Para protegerse de descargas eléctricas, **NO** sumerja el cable, los enchufes o la unidad principal en agua u otros líquidos.
- 14 Durante el uso, no toque el borde interior de la olla, la carcasa exterior, el mango de la cesta para asar, el mango de la rejilla de la parrilla y la superficie de la cubierta superior para evitar quemaduras.
- 15 **ADVERTENCIA:** Superficies calientes.
ATENCIÓN: Antes de usar por primera vez, retire todas las pegatinas promocionales y materiales de embalaje y limpie el recipiente interior, la cubierta superior, etc. de la máquina.
- 16 **NO** toque los accesorios durante el cocinado o inmediatamente después de este. La parrilla y la cesta pueden alcanzar altas temperaturas durante el cocinado. Evite tocar el accesorio al extraerlo del aparato. Para prevenir quemaduras o lesiones, tenga cuidado **EN TODO MOMENTO** al manejar el producto. Se recomienda el uso de utensilios de brazo largo y manoplas o guantes para horno aislantes.
- 17 Durante la fritura con aire caliente, se libera vapor caliente a través de las salidas de aire. Mantenga las manos y la cara a una distancia segura del vapor y de las salidas de aire. También tenga cuidado con el vapor y el aire calientes cuando retire la sartén de los electrodomésticos.
- 18 Para desconectarla, apague cualquier control y, a continuación, desenchufe el aparato de la toma de corriente mientras no esté en uso y antes de limpiarlo.

DESCRIPCIÓN DE PIEZAS

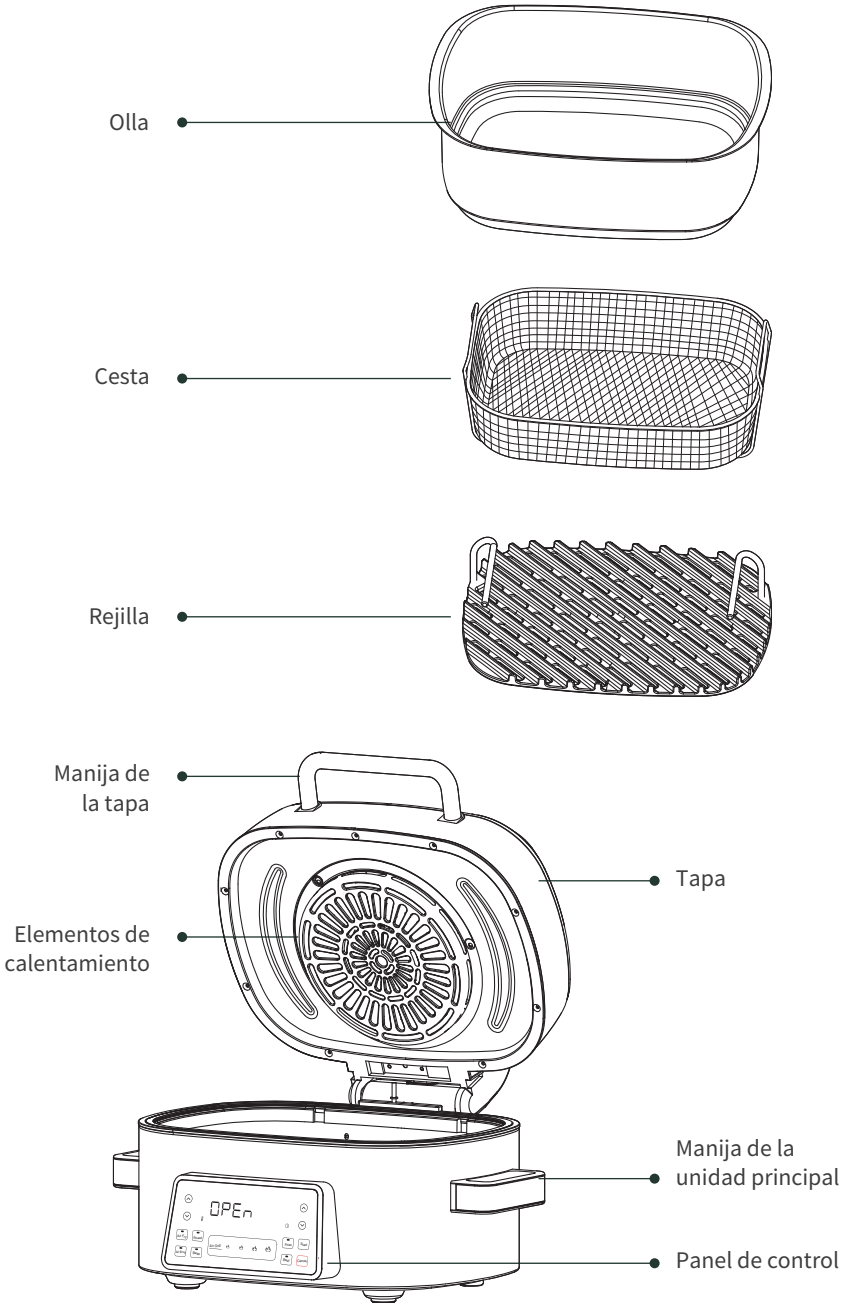

PANEL DE CONTROL



Operación:

| | | | |
|--|-------------------------------------|------------------|---|
| | Pulse para bajar la temperatura. | | Pulse para seleccionar la función de Fries. |
| | Pulse para aumentar la temperatura. | <u>Air Grill</u> | Pulse para seleccionar la función de Air Grill (bajo, medio, alto, máximo). |
| | Pulse para aumentar el tiempo. | | Pulse para seleccionar la función de Roast. |
| | Pulse para disminuir el tiempo. | | Pulse para seleccionar la función de Bake. |
| | Pulse para comenzar a cocinar. | | Pulse para seleccionar la función de Air Broil. |
| | Pulse para cancelar la cocción. | | Pulse para seleccionar la función de Air Fry. |

FREÍR CON AIRE

1. Pulse el botón "Air Fry", se visualizará la temperatura y el tiempo predeterminados.



2. Pulse el botón para ajustar la temperatura y el tiempo.



3. Pulse el botón "Start", para comenzar a precalentar, aparecerá la palabra "PrE" en la pantalla.

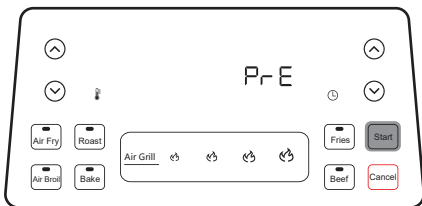

4. Al finalizar precalentarse, se visualizará "Add", abra la tapa y el aparato deja de funcionar, aparecerá la palabra "OPen" en la pantalla.



5. Coloque los ingredientes en la cesta. Cuando se cierre la tapa, el temporizador empezará la cuenta atrás.

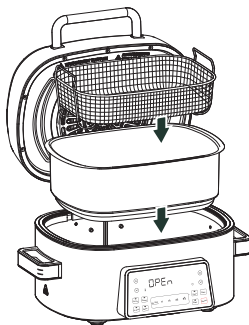

6. Cuando termine la cuenta atrás, aparecerá la palabra "donE" en la pantalla.



7. Pulse el botón "Cancel", para entrar en modo de espera, aparecerá la palabra "OFF" en la pantalla.

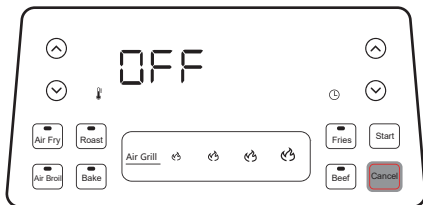

TOSTAR

1. Pulse el botón **"Roast"**, se visualizará la temperatura y el tiempo predeterminados.



2. Pulse el botón para ajustar la temperatura y el tiempo.



3. Pulse el botón **"Start"**, para comenzar a precalentar, aparecerá la palabra "PrE" en la pantalla.

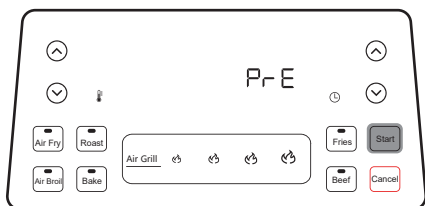

4. Al finalizar precalentarse, se visualizará "Add", abra la tapa y el aparato deja de funcionar, aparecerá la palabra "OPEN" en la pantalla.



5. Coloque los ingredientes en la cesta. Cuando se cierre la tapa, el temporizador empezará la cuenta atrás.

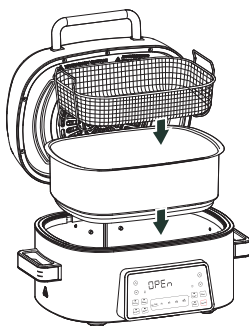

6. Cuando termine la cuenta atrás, aparecerá la palabra "donE" en la pantalla.



7. Pulse el botón **"Cancel"**, para entrar en modo de espera, aparecerá la palabra "OFF" en la pantalla.

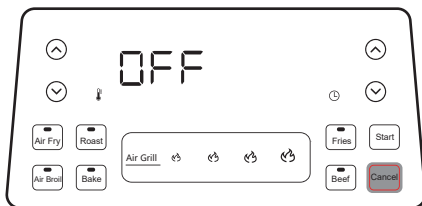

ASAR CON AIRE

1. Pulse el botón **"Air Broil"**, se visualizará la temperatura y el tiempo predeterminados.

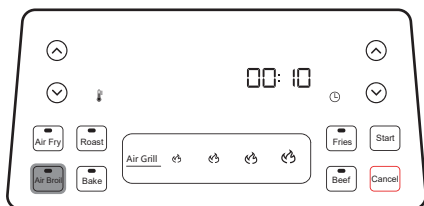

2. Pulse el botón **para ajustar el tiempo**.

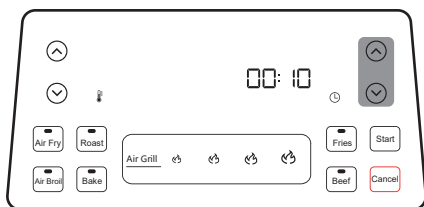

3. Pulse el botón **"Start"**, para comenzar a precalentar, aparecerá la palabra **"PrE"** en la pantalla.

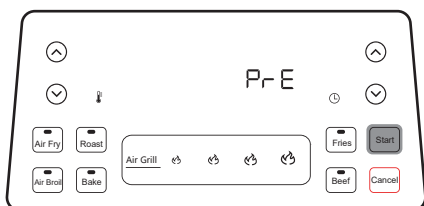

4. Al finalizar precalentarse, se visualizará **"Add"**, abra la tapa y el aparato deja de funcionar, aparecerá la palabra **"OPEn"** en la pantalla.

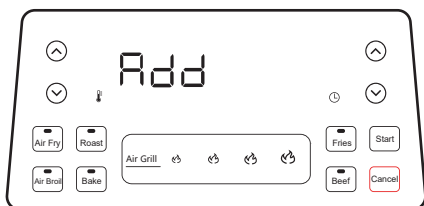

5. Coloque los ingredientes en la cesta. Cuando se cierre la tapa, el temporizador empezará la cuenta atrás.

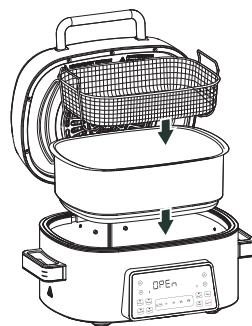

6. Cuando termine la cuenta atrás, aparecerá la palabra **"donE"** en la pantalla.



7. Pulse el botón **"Cancel"**, para entrar en modo de espera, aparecerá la palabra **"OFF"** en la pantalla.



HORNEAR

1. Pulse el botón **"Bake"** se visualizará la temperatura y el tiempo.



2. Pulse el botón para ajustar la temperatura y el tiempo.



3. Pulse el botón **"Start"**, para comenzar a precalentar, aparecerá la palabra "PrE" en la pantalla.

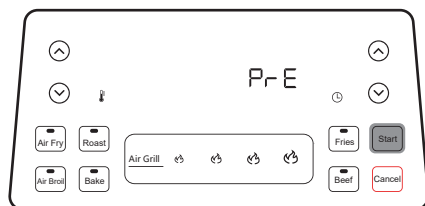

4. Al finalizar precalentarse, se visualizará "Add", abra la tapa y el aparato deja de funcionar, aparecerá la palabra "OPEn" en la pantalla.

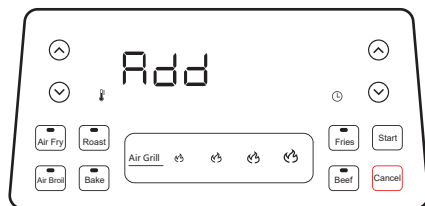

5. Coloque los ingredientes en la cesta. Cuando se cierre la tapa, el temporizador empezará la cuenta atrás.

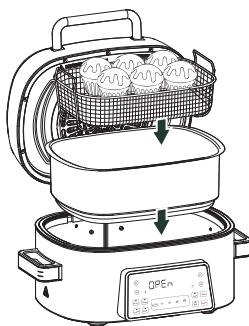

6. Cuando termine la cuenta atrás, aparecerá la palabra "donE" en la pantalla.



7. Pulse el botón **"Cancel"**, para entrar en modo de espera, aparecerá la palabra "OFF" en la pantalla.

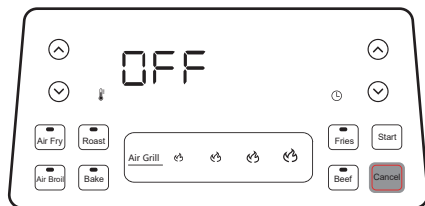

PATATAS FRITAS

1. Pulse el botón "Fries" se visualizará la temperatura y el tiempo.



2. Pulse el botón para ajustar la temperatura y el tiempo.



3. Pulse el botón "Start", para comenzar a precalentar, aparecerá la palabra "PrE" en la pantalla.

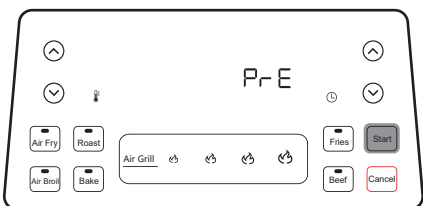

4. Al finalizar precalentarse, se visualizará "Add", abra la tapa y el aparato deja de funcionar, aparecerá la palabra "OPen" en la pantalla.



5. Coloque los ingredientes en la cesta. Cuando se cierre la tapa, el temporizador empezará la cuenta atrás.

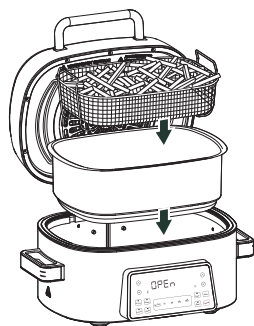

6. Cuando termine la cuenta atrás, aparecerá la palabra "donE" en la pantalla.



7. Pulse el botón "Cancel", para entrar en modo de espera, aparecerá la palabra "OFF" en la pantalla.

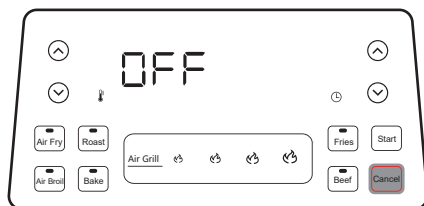

ATENCIÓN: Para obtener los mejores resultados de cocción, recomendamos agitar los ingredientes durante la cocción.

Cuando abra la tapa, el dispositivo se detendrá automáticamente y aparecerá 'OPen' en la pantalla. Use guantes para horno para sacudir la canasta. La cocción se reanuda cuando se vuelva a colocar la cesta y se cierre la tapa.

CARNE DE RES

1. Pulse el botón **"Beef"** se visualizará la temperatura y el tiempo.



2. Agregue la parrilla a la freidora de aire.

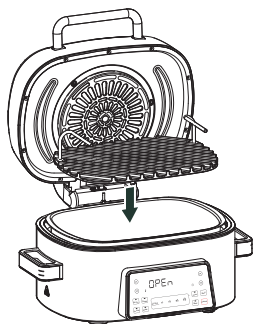

3. Pulse el botón para ajustar la temperatura y el tiempo.



4. Pulse el botón **"Start"**, para comenzar a precalentar, aparecerá la palabra "PrE" en la pantalla.

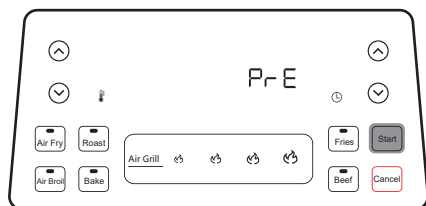

5. Al finalizar precalentarse, se visualizará "Add", abra la tapa y el aparato deja de funcionar, aparecerá la palabra "OPEn" en la pantalla.

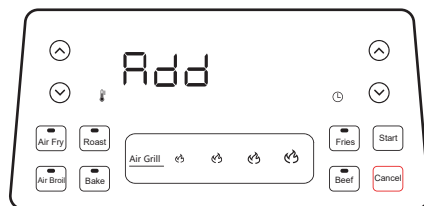

6. Coloque los ingredientes en la cesta. Cuando se cierre la tapa, el temporizador empezará la cuenta atrás.

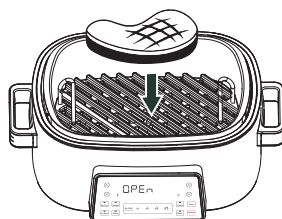

7. Cuando termine la cuenta atrás, aparecerá la palabra "donE" en la pantalla.



8. Pulse el botón **"Cancel"**, para entrar en modo de espera, aparecerá la palabra "OFF" en la pantalla.

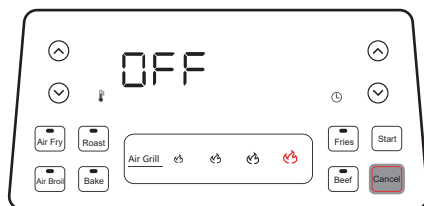

PARRILLA DE AIRE

| Función | Predeterminado | Rango de Temperatura | Rango de tiempo |
|------------------------|----------------|----------------------|----------------------|
| Air Grill (bajo) | 200°C 00:15 | / | 1-30min 1min/paso |
| Air Grill (medio bajo) | 220°C 00:15 | / | |
| Air Grill (medioalto) | 240°C 00:15 | / | |
| Air Grill (alto) | 265°C 00:10 | / | |

1. Pulse el botón "🔥" Para seleccionar el modo "Air grill " deseado.se visualizará la temperatura y el tiempo.

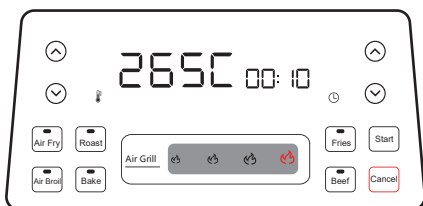

2. Agregue la parrilla a la freidora de aire.

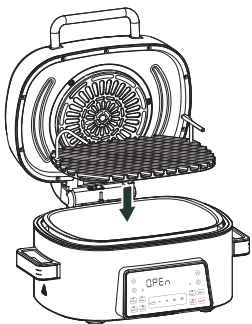

3. Presiona hacia arriba y hacia abajo para ajustar el tiempo. Pulse el botón "Start" Para iniciar el calentamiento, aparece "PrE" en la pantalla.



4. Al finalizar precalentarse, se visualizará "Add", abra la tapa y el aparato deja de funcionar, aparecerá la palabra "OPEn" en la pantalla.

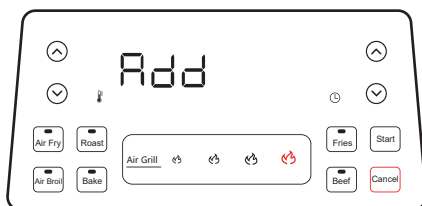

5. Agregue los ingredientes a la parrilla, cierre la tapa y el aparato comenzará a cocinar automáticamente.

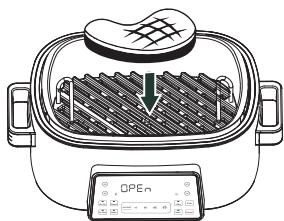

6. Cuando termine la cuenta atrás, aparecerá la palabra "done" en la pantalla.



7. Pulse el botón "Cancel", para entrar en modo de espera, aparecerá la palabra "OFF" en la pantalla.



ATENCIÓN: Durante el proceso de cocción, puede abrir la tapa para comprobar la comida o darle la vuelta; la máquina se detiene automáticamente cuando se abre la tapa y reanuda la cocción después de cerrarla.

LIMPIEZA

La unidad debe limpiarse a fondo después de cada uso.

SIEMPRE deje que el aparato se enfríe antes de limpiarlo.

Desenchufe la unidad del enchufel de pared antes de limpiarla

1. Retire el enchufe principal de la toma de corriente y deje que el aparato se enfríe durante al menos 30 minutos.
2. Retire los accesorios para dejar que la freidora de aire se enfríe antes de limpiarla.
3. Limpie el aparato después de **CADA** uso. **NO** limpie los accesorios y el interior del electrodoméstico con utensilios de cocina de metal o materiales de limpieza abrasivos, ya que esto puede dañar el revestimiento.
4. Limpie el exterior del aparato con un paño mojado.
5. Limpiar los accesorios con agua caliente, un poco de detergente líquido y una esponja no abrasiva.
6. Puedes eliminar cualquier resto de comida con líquido desengrasante.
7. Las piezas limpias deben secarse antes de enchufarla.

RESOLUCIÓN DE PROBLEMAS

• Aparece "ADD" en la pantalla del panel de control.

La unidad ha completado su precalentamiento y ahora es el momento de agregar sus ingredientes.



• E1 o E2 aparece en la pantalla.

La unidad no funciona correctamente. Favor de contactar servicio de posventa.



• ¿Cómo hago una pausa en la unidad para poder revisar mi comida?

Cuando se abre la tapa durante una función de cocción, la unidad se detendrá automáticamente. La pantalla mostrará "OPEN".



• ¿Es seguro poner la freidora de aire en mi encimera?

La freidora de aire se calentará durante la cocción. Tenga cuidado al manipularla y colóquelo solo en superficies resistentes al calor.

• Mi comida no está cocida después de cocinar.

Para un dorado uniforme, asegúrese de que los ingredientes estén dispuestos en una capa uniforme en el fondo de la rejilla para asar sin que se superpongan. Agite la comida para aflojarla durante la cocción.

• ¿Tiempo de precalentamiento es demasiado largo?

La parrilla necesita absorber más calor para una cocción óptima, el precalentamiento a baja temperatura ambiente puede llevar más tiempo, y si juzga que la temperatura interna de la olla ya es lo suficientemente alta, puede omitir manualmente la etapa de precalentamiento.

• ¿Cómo omitir el precalentamiento?

"PrE" se mostrará cuando el dispositivo esté en modo de calentamiento, momento en el que mantenga presionada el "Start" durante 3 segundos para omitir el calentamiento. El calentamiento se puede omitir solo cuando se calienta.

• Reciclaje adecuado de este producto.

 El símbolo indica que el producto no debe desecharse como residuo sin clasificar, sino que debe enviarse a instalaciones de recogida selectiva para su recuperación y reciclaje. Para evitar que la eliminación incontrolada de desechos dañe el medio ambiente o la salud humana, debe reciclarse de manera responsable para promover la reutilización sostenible de los recursos materiales. Para devolver un dispositivo antiguo, utilice el sistema de devolución y recogida o póngase en contacto con el minorista que compró el producto. Pueden usar este producto para un reciclaje seguro para el medio ambiente.

Customer Service

| | |
|----------------|---------------------------------|
| United States | service-us@chefree-official.com |
| Deutschland | service-de@chefree-official.com |
| France | service-fr@chefree-official.com |
| España | service-es@chefree-official.com |
| Canada | service-ca@chefree-official.com |
| United Kingdom | service-uk@chefree-official.com |
| Italia | service-it@chefree-official.com |
| 日本 | service-jp@chefree-official.com |
| Others | support@chefree-official.com |