

# STARTING SYSTEMS BROCHURE

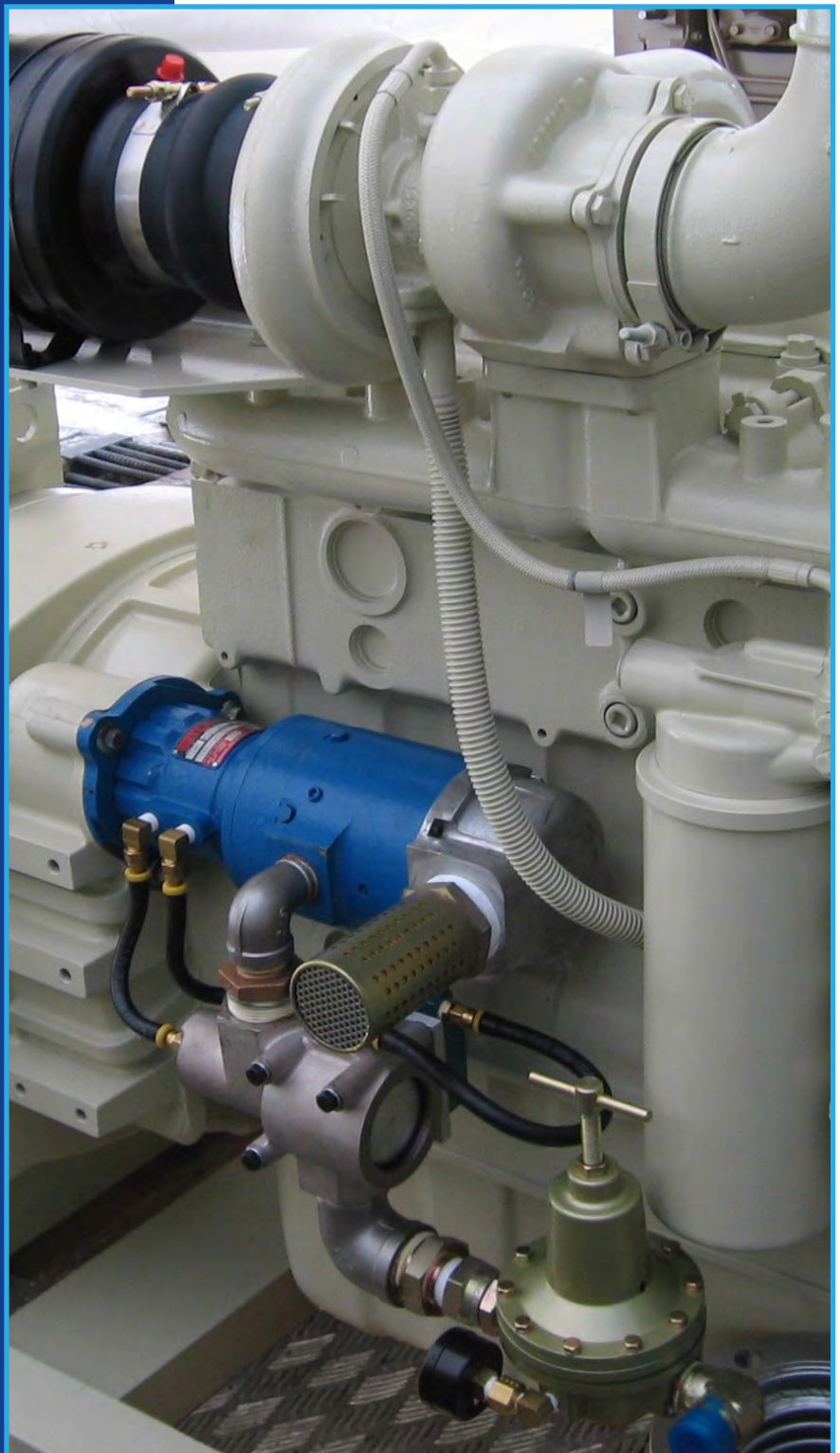

## Your single source to start any industrial engine

A number of methods can be used to start an industrial engine. Methodes generally used by OEM's, packagers and end users are:

- A hydraulic starter, linked to the engine flywheel that is equipped with a ring gear, or linked to a gearbox shaft.
- An air starter, linked to the engine flywheel that is equipped with a ring gear, or linked to a gearbox shaft.
- An "air in head" distributor-start system. This system distributes compressed air in the right order into the cylinder head so that the engine is set in motion.
- A mechanical spring starter, linked to the engine flywheel that is equipped with a ring gear.
- An electric starter, linked to the engine flywheel that is equipped with a ring gear.

Hatraco is specialized in different methods of starting systems as detailed above for various vertical markets and applications:

- Oil and gas
- Marine and offshore
- Industry and mining
- Reciprocating engines and gas turbines
- Diesel- and gas fired engines

Working together with worldwide well known starting equipment manufacturers like TECH DEVELOPMENT, KOCSIS TECH INC., ALTRONIC, KINETECO and BOSCH has led to a situation where Hatraco is being recognized and well positioned in the market as the single source starting system specialist who helps you to start your engine. Whether you are in a need for a complete starting system, application engineering, separate parts or just an advise, our goal remains to help you with a technical effective and economic starting method for the initial purchase as well as the long term usage of the product.

Hatraco is familiar with common marine class societies like European and American design standards, oil and gas- and fire pump standards like respectively, DNV-GL, LR, BV, ABS, CE, PED, ATEX, API, ASME, CSA, NFPA-20.

**For a customized advice, please contact one of our offices.**



# OUR COMPANY

## Hatraco

Hatraco is manufacturer, European distributor and worldwide supplier of customized industrial engine equipment supported by world leading manufacturers which are developed and produced in-house.

Hatraco provides equipment for stationary gas-, diesel engines and gas turbines for the industry, marine, oil & gas and power generation in all sorts of applications.

With a wide range of engine parts and control systems, we help customers run their engine, improve their engine efficiency and contribute to a cleaner environment.

## ISO Certification

Hatraco is ISO 9001:2015 certified. The ISO 9001:2015 is the international standard for quality management systems which focuses on continuous assurance and improvement of quality. This helps Hatraco ensure our customers consistently receive high quality products and services.

## Market sectors

Oil & Gas

Marine & Offshore

Industry

Mining



## Contact

### Website

www.hatraco.com

### E-mail

sales@hatraco.com

### Telephone

+31 316 280 191

### Fax

+31 316 281 161



## Disclaimer

The contents of this brochure has been compiled with the greatest possible care and is intended for general information and marketing purposes only and does not constitute advice. The information contained in this brochure is provided as is and without any warranties of any kind, whether expressed or implied, including but not limited to, implied warranties of satisfactory quality, fitness for a particular purpose and/or correctness. No rights can be derived from the contents of this brochure.

All rights reserved. No part of this publication may be reproduced in any form or by any means, including photocopying, recording, or other electronic or mechanical methods, without the prior written permission of the publisher, except in the case of brief quotations embodied in reviews and certain other noncommercial uses permitted by copyright law.

# INDEX

## Hydraulic starting systems

Hydraulic systems	6
Typical applications	7
Equipment and components	8
Accumulators & Pumps	8
Starter specifications	9
Valves, filters & reservoirs	9

## Air starting systems

Hatraco air starting systems	12
Typical applications	13
Equipment and components	14
Gas turbines (gearbox) & TDI TURBOGUARD™	16
TDI TurboValve & TDI TurboFlow Air Regulator	17
The SaveAir system	18
Things to know about Hatraco air starting systems	19

## Spring starting systems

Mechanical (spring) starting system	22
Kineteco starter ranges by spring type	23
Typical applications	23
Equipment and components	24
Spring starter specifications	25

## Electric starting systems

Electric starting	26
Typical applications	26
Product features	27



# HYDRAULIC STARTING SYSTEMS



## Hydraulic starting systems

Hydraulic starting systems are the perfect solution when it comes to engine starting, either in a normal or critical situation. Powered by Kocsis Technologies Inc. products, Hatraco's hydraulic starting systems are extremely reliable under the hardest conditions, nearly unaffected by extreme temperatures and suitable for on- and offshore application. By manual operation and using a hand pump, hydraulic starting systems are capable of overcoming a "black start" condition proving to be critical during emergency situations. Hatraco's hydraulic starting systems are available in standard configuration or fully customized and can be purchased whether as an assembled kit or in separate components.

## Standard system range

The available standard range is based on system capacity as function of engine displacement and start duration. The standard range covers engines from 1 up to 100 litres and a start duration in increments from 5, 15, 30 and 90 seconds.

## Customized systems

Besides the standard range, Hatraco also offers fully designed systems according to required specifications for marine, offshore, oil and gas, industry and mining vertical markets.

# HYDRAULIC STARTING SYSTEMS

This hydraulic start system is developed to charge, store and release hydraulic fluid in hydro pneumatic accumulators at high pressure. The hydraulic fluid is pumped by means of a manual-, motor- or engine driven pump from the hydraulic reservoir to the hydro pneumatic accumulator. On its way from the hydraulic reservoir to the pump the hydraulic fluid passes through a first stage low pressure filter. From the pump to the accumulator it's directed through a second stage high pressure filter. By means of a pre-charged hydro pneumatic accumulator the pressure is build up to 207 bar which equals the maximum operating pressure of the system.

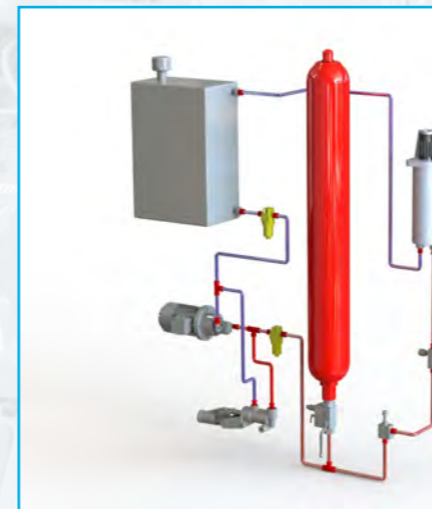

When the maximum pressure is reached the pump will be switched off. When it drops below a pre defined minimum pressure level the pump will be switched on again.

In case of a starting event a manual-, electromagnetic- or pneumatic operated valve releases the accumulator pressure and clears the way for the hydraulic fluid towards the piston type starter motor.

Before the hydraulic fluid enters the starter motor it passes through a soft engagement valve. This valve ensures a smooth engagement and pressure build-up of the starter motor pinion with the ring gear of the flywheel. The hydraulic fluid that went through the starter motor is returned to the hydraulic reservoir.

## Benefits

- Standard SAE- and special mounting flanges available to fit every engine make and model
- Higher torque and speed resulting in faster, more efficient engine starting than other starting methods
- With the addition of a NON spark pinion, the hydraulic starter is ideal for explosive atmospheres and meets ATEX and CSA Class 1, Div. 1 environment standards
- Hydraulic starting systems are nearly unaffected by extreme temperatures and provide perfect cold- and hot weather starts
- By means of the hand pump, hydraulic starting systems are capable of overcoming a "black start" condition proving to be critical during emergency situations
- Recharging of the system takes only minutes by means of a motor driven pump
- Due to constant lubrication of the moving parts, hydraulic starting systems often survive the lifetime of the engine, which results in less "lifetime costs"
- 100% of the hydraulic assemblies come with a Factory Acceptance Test to insure the best quality

## Typical applications

### Marine and offshore

- Auxiliary engines
- Emergency gensets
- Propulsion engines (life boats)
- Cranes
- Fire fight pumps (FIFI)
- Compressor installations

### Onshore Oil and Gas

- Fire fight pumps (NFPA-20)
- Black start generators
- Emergency generators
- Compressor installations
- Hydraulic fracturing

### Industry and Utilities

- Black start generators
- Emergency generators
- Compressor installations
- Fire fight pumps
- Mobile equipment (zoned areas)

### Agriculture

- Tractors
- Water pumps
- Generators

### Mining

- Transporters
- Train locomotives
- Haul trucks
- Drilling equipment
- Pumps

# HYDRAULIC STARTING SYSTEMS

## Equipment and components

### Starter Hydrotor®

The patented Hydrotor® starter motor has been proven through many years of reliable service under environmental extremes worldwide. Various models of fixed displacement piston motors capable of effective hydraulic starting of engines up to 100 litres engine displacement are available:



- Type A: for engines up to 9 litres
- Type B: for engines up to 18 litres
- Type C: for engines up to 30 litres
- Type D: for engines up to 70 litres
- Type E: for engines up to 100 litres

All starters are available with the common SAE type flanges for an easy installation. Besides the common SAE flanges we offer the less common flanges as well, like Volvo and Mitsubishi flanges.

## Accumulators

With standard lines of 207 bar (3.000 psi), 345 bar (5.000 psi) and 689 bar (10.000 psi), KTI accumulators effectively cover the commercial range. We also offer a significant range of customized accumulators, which are only limited by the size of our machines.

Our accumulators are available with the common classifications and certifications DNV-GL, LR, BV, ABS, CE- PED, ASME.



## Pumps

Offered in numerous variations, the KTI recharging pump is driven by some form of prime mover (engine PTO or electric motor) to recharge the hydraulic starting system for starting attempts.

Featuring a built-in unloading valve, the recharging pump unloads when the pre-defined system pressure has been reached. While in this state, the pump is fully lubricated and can run continuously without issue.

The KTI hand pump is a manual pump capable of regenerating system pressure for a starting attempt. Equipped with a 91 cm lever, the manual pump operates on “human” power and can recharge a hydraulic system in a black start condition. The hydraulic starting system is the only system (above 15 litres engine displacement) capable of being recharged manually thus one more reason why it's relied upon in emergency starting applications.

# HYDRAULIC STARTING SYSTEMS

## Starter specifications

TYPE	A	B	C	D	E
Max. engine displ.	9 L	18 L	30 L	42 L	100 L
Max. torque	20 Nm	61 Nm	98 Nm	163 Nm	271 Nm
Max work. pressure	207 bar	207 bar	207 bar	207 bar	207 bar
Drive type	Inertia	Inertia	Inertia	Inertia	Inertia
Flange	SAE 1, 2/3, 4, 5, special	SAE 1, 2/3, 4, 5, special	SAE 1, 2/3, 4, 5, special	SAE 1, 2/3, 4, 5, special	SAE 1, 2/3, 4, 5, special
Displacement	8.2 cm <sup>3</sup>	22.1 cm <sup>3</sup>	32.75 cm <sup>3</sup>	57.35 cm <sup>3</sup>	98.35 cm <sup>3</sup>
Efficiency	92%	92%	92%	92%	92%
Speed range	0-7000 RPM	0-7000 RPM	0-4500 RPM	0-4500 RPM	0-3000 RPM
Weight	5 Kg	7.7 Kg	16 Kg	18 Kg	21 Kg

## Valves

There are several options when it comes to control valves. For those who are looking to actuate the hydraulic starting system manually, the two main options include foot pedal actuated and Bowden wire actuated valves. For operators interested in controlling starting system actuation via HMI (panel interface), KTI offers several options of solenoid operated valves that meet industry requirements including explosion proof.



The soft engage valve is a pilot operated valve mounted between the control valve and hydraulic starter within the starting system. As the system fluid passes through the control valve, a small amount of oil is delivered to the starter motor allowing the smooth engagement of the pinion gear and the flywheel ring gear. Once the gears mesh, the valve opens completely and delivers full system fluid. The result is a smooth, powerful engine start.

## Filters

This high pressure filter, made of high strength, seamless carbon steel tubing is typically mounted between the pump and the accumulator. This in-line filter provides 40 micron filtration with minimal flow restriction.

This low pressure filter, made of high strength, seamless carbon steel tubing is easily mounted to the hand pump suction line. With a 40 micron rated filter element, this component provides the right amount of filtration with minimal flow restriction.

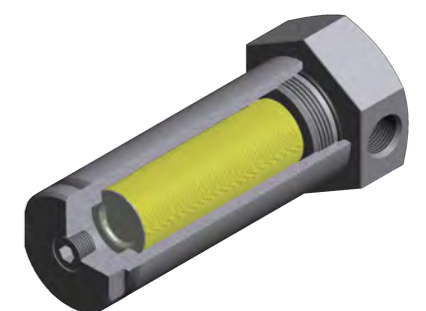

## Reservoir

KTI tanks feature painted heavy gage steel with a fully removable lid for easy maintenance. The filler breather cap is made of high quality, chrome plated steel. Each tank includes an easily readable sight level gauge, which conveniently allows the monitoring of oil in the system.



**KTI TEAM**  
*Kocsis Technologies Inc.*

**“ For fast, sure,  
high torque  
engine cranking ”**

**Kocsis Technologies Inc**

Often imitated but never duplicated, Kocsis Technologies, Inc. Hydrotor® hydraulic starting systems have continually provided reliable engine starting in the harshest environments since 1990. This performance is due to the efforts of a technically skilled and dedicated team of professionals found in our Engineering, Manufacturing and Sales departments.

**Engineering & manufacturing**

Our engineering group’s hydraulic and engine starting expertise supports component development as well as system design. Furthermore, challenging starting applications are commonly addressed with customized solutions and in-depth technical support.

A state of the art, in-house manufacturing capability operated by an experienced workforce results in consistent product quality and timely deliveries. KTI components are precisely machined from the highest grade materials, inspected to strict quality standards, assembled into product and functionally tested to carefully engineered specifications.

**Sales**

Our attentive and knowledgeable sales department provides customers with timely quotations, frequent project status updates, marketing support, and on-site visits.

Ultimately, the supply of premium hydraulic starting products is no accident. It is a culmination of our team’s hard work and talent which produces positive results worldwide.

**“ Thrive where  
lesser starters  
simply do not ”**



**DAVE RAWLINS**  
Senior Product Manager  
*Tech Development*

**Quality & Reliability**

TDI has engineered our turbine powered starters to take on the dirtiest, coldest, and most demanding places on earth. TDI TurboTwin™ starters survive in environments where the supply air is often contaminated with water, pipe scale, rust or even H2S, and in places where frequent starting and long cranking cycles are the norm. In places where engine starting system maintenance may not be the best, TDI TurboTwin starters thrive where lesser starters simply do not survive.

TDI TurboTwin’s solid performance in extreme environments has set the industry standard for reliability, but it’s also unmatched for reducing the life cycle cost, improving safety, and ease of installation. TDI offers a full range of starters to fit engines from 2L up to 300L with a single starter. In addition TDI designs and manufactures system accessories such as our flow matched TurboFlow Regulators and TurboValve relay vales for maximizing the efficiency of the air system and to maximize the number of starts which can be achieved from a fixed volume air system. TDI quality is second to none as everything we design and produce is manufactured to our ISO9001 and AS9100 certified quality system.

**Performance**

TDI also leads the industry in low pressure starting capability and minimizing the space required for air receiver which means you can eliminate the high cost and physical space required to meet specifications which other starters often multiple air receiver tanks. It also means you will use less air or achieve more starts from the existing tanks. TDI performance doesn’t stop there. TDI manufactures the lightest starters in the industry so shipping, handling, and installation are easily handled by one person. Using TDI starting system accessories and controls, you can literally bolt on a TurboTwin upgrade in minutes. And after it’s installed, our turbine technology means your engine room stays cleaner, quieter, and safer. TDI innovative products continue to lead the industry and the introduction of the new TDI TurboGuard™ starter is just another example of how TDI has been solving difficult starter applications for over 40 years.

**Now that’s what we call  
performance!**

# AIR STARTING SYSTEMS

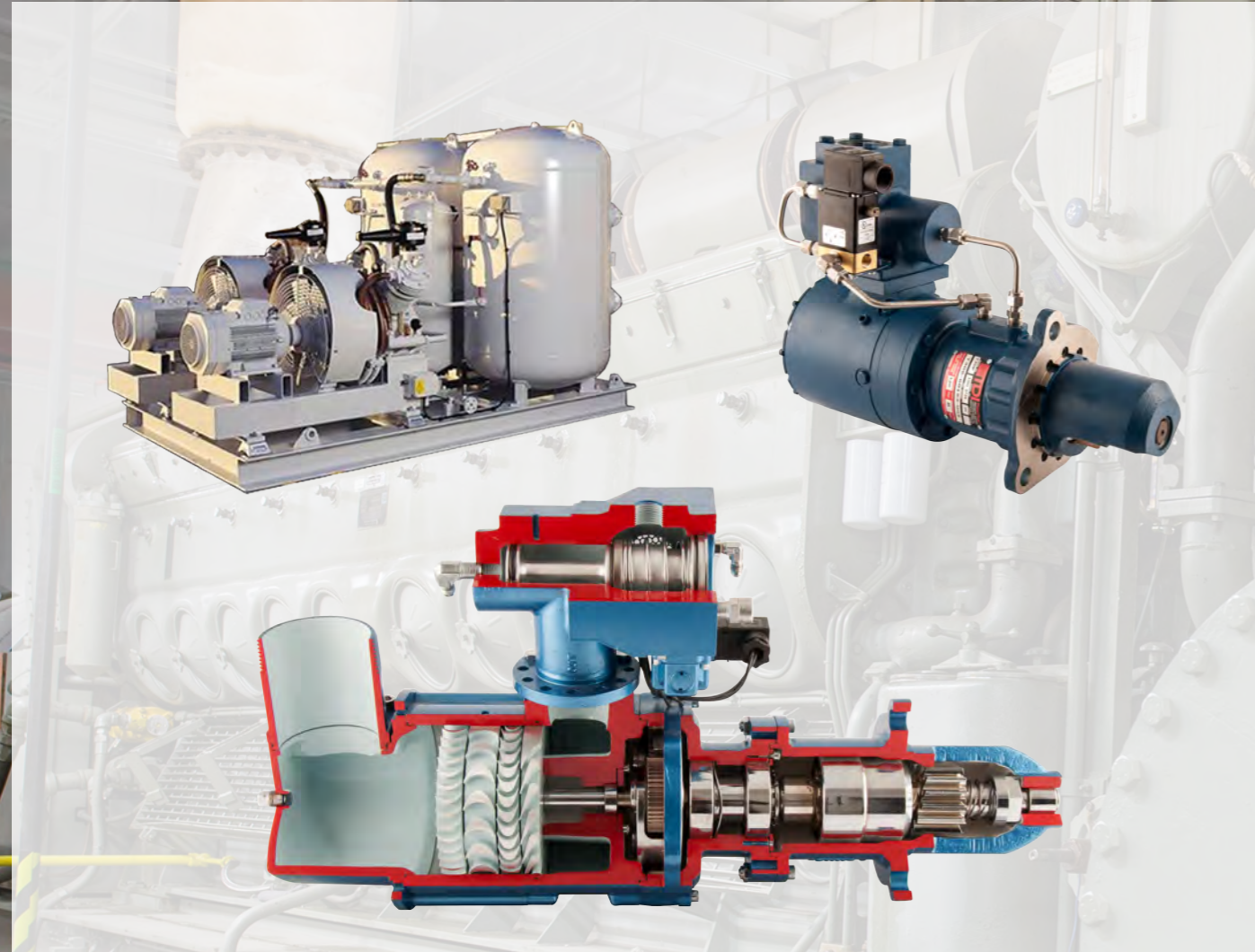

## Hatraco air starting systems

Hatraco supplies all the equipment necessary to deliver starting air and cranking torque to your engine. Whether it is a combined heat and power application, emergency generator, pump set, a large gas compressor or gas turbine, Hatraco provides air starting systems fully designed and manufactured according to client- and project specifications.

## Reciprocating engine starting (ring gear)

Hatraco collaborates with (TDI) Tech Development. TDI Air starters use reliable turbine technology which is based on aerospace technology. The same spirit that has designed some of the most advanced turbine systems for the aerospace industry continues to drive the development of even more reliable and efficient air starters. TDI is recognized worldwide by every OEM and significant system packager as the leader for highly reliable starting of reciprocating engines.

## Reciprocating engines (Air-in-head)

Hatraco applies SaveAir™ systems for air-in-head starting. The SaveAir™ electronic air starting system brings solid-state electronic control to the starting function on air-in-head starter equipped integral compressor engines. Eliminating many of the mechanical air-start related components, the solid-state SaveAir™ system introduces significant operational advantages, including a substantial reduction in the required starting air (up to 70%) and the elimination of starting “dead spots”.

# AIR STARTING SYSTEMS

## Ring gear air starting system

Air is compressed and pressurized by piston- or screw type compressors. This air is stored in air receivers. In case of a starting event a manual- or solenoid operated valve gets activated and clears the way for the pilot air to open the pre-engaged valve in case of a pre-engaged starter or to open the relay valve directly in case of a inertia type starter.

In case of a pre-engaged starter type, the pilot air ensures engagement of the pinion with the ring gear of the engine flywheel. After full engagement of the pinion the pilot air will switch the relay valve to open and clear the way for the main air flow that will drive the turbine wheels of the starter.

Different from pre-engaged type starters are inertia type starters where the pilot air will directly open the relay valve to allow the main air flow to drive the turbine wheels of the starter.

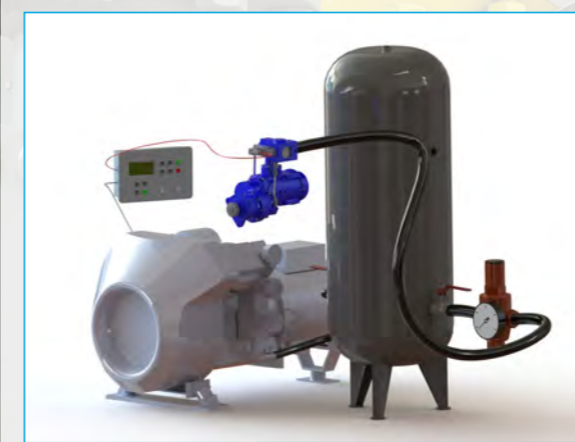

By driving these turbine wheels the pinion drive gets activated by the translation of the rotational- into a linear movement of the pinon created by “inertia” and engages with the ring gear of the flywheel. In both cases the used air gets released into the atmosphere.

Generally a maximum system pressure of 30-40 bars is used. When the pressure drops in case of a starting event, the compressor starts to refill the receivers until the pre-defined set pressure is re-established.

Besides compressed air TDI turbine starters can be started with compressed gas as well, which can be ideal in case of an application in a gas field or compressor station for example.

## Benefits

- Standard SAE- and special mounting flanges available to fit every engine make and model
- Ultra-low pressure starts, TDI provides reliable starts on pressures as low as 2-4 bar already
- Not harmed by contaminated air. No rubbing vanes to stick, swell or wear out
- No oil to be added to the supply air, no hazardous fugitive mist, no messy oil discharge
- Low maintenance, gearbox greased for life
- Light of weight
- Higher power to weight ratio then others, more power & faster starts
- World-wide recognized by nearly every engine OEM
- Aerodynamic speed control, Self-cooling, longer cranking

## Typical applications

### Marine and offshore

- Auxiliary engines
- Emergency gensets
- Propulsion engines (*life boats*)
- Fire fight pumps (*FIFI*)
- Compressor installations

### Onshore Oil and Gas

- Fire fight pumps (*NFPA-20*)
- Emergency generators
- Compressor installations

### Industry and Utilities

- Emergency generators
- Compressor installations
- Fire fight pumps
- Mobile equipment (*explosive atmospheres*)

### Mining

- Transporters
- Train locomotives
- Haul trucks
- Drilling equipment
- Pumps

# AIR STARTING SYSTEMS

## Equipment and components

### TDI Air Starters

TDI pioneered turbine air starters for reciprocating engines in 1979 by delivering reliable performance in the world's harshest environments. Their reputation and market share has grown ever since making TDI TurboTwin and TurboStart the most prevalent turbine air starters in the oil and gas industry, on the open waters, at utility power plants, and on mining vehicles around the world. Available TDI starter types:



**Type T25:** for engines up to 16 litres

Lots of power in a small footprint. At just 121mm (4.75") diameter and less than 275mm (11") long, T25 delivers 21kW, (27hp) @ 6.2 BAR (90psig) on a 12 nozzle package. T25 redefines robust starting and reliability for small space applications.

**Type T30:** for engines up to 20 litres

The T30 generates up to 25% more stall torque than other starters in its class. Its highly efficient twin-turbine motor design gives you more cranking power with less air for faster starts. Unlike starters that require a mechanical automatic trip valve (ATV), the T30 uses aerodynamics to control motor speed, giving you total control over the start cycle. T30 is available in a inertia, pre-engaged and pre-engaged overhung version.



**Type T50:** for engines up to 80 litres

T50 are versatile, mid-size turbine air starters designed for a wide variety of challenging environments like mines, at sea or oil and gas fields where downtime can cost hundreds of thousands of dollars. T50 is available in an inertia, pre-engaged and pre-engaged overhung version.



**Type T100:** for engines up to 300 litres

T100B provides ultimate, inertia-engaged reliability for large engines up to 250 litres. Long cranking cycles, contaminated air, and improper maintenance have almost no effect on the T100. The T100-B inertia-engaged starter is designed for your most critical applications.



The pre-engaged T100-V provides ultimate reliability for large engines up to 300 litres. Long cranking cycles, contaminated air, and improper maintenance have almost no effect on the T100-V.



**Type "TurboTwister" T6 / T7:** for engines up to 150 litres

TurboTwister is a study in rugged simplicity. TDI engineered the starter version to include a new solenoid design which is more tolerant to contamination and vibration which are often present in typical applications. The result is a rugged, reliable air starter. It will be less susceptible to failure in harsh environments, thereby lasting longer, which will actually reduce the cost of ownership.

Available in various configurations:  
 T6 A : Starter only;  
 T6 B : Starter with integrated relay valve;  
 T6 C : Fully integrated start system;  
 T7 : Stand alone / Gas compliant.

**Type "TurboStartTwo" (45M):**  
 for engines up to 115 litres with integrated relay valve, muffler, outlock & overspeed protection.

More than an air starter, TurboStartTwo isn't just an air starter, it's an integral starting system that includes :

1. A powerful air motor
2. Built-in controls with pre-programmed safeguard logic
3. A flow-match relay valve
4. An electric solenoid
5. An integral muffler
6. Both pilot air control lines/fittings
7. A simple plug-in interface to your engine control

It even has an emergency manual bypass provision, allowing you to start just on air if needed. On a new engine, it is literally a five-minute installation.





# AIR STARTING SYSTEMS

TYPE	T25	T30	T50	T100	45M	T6/T7
Max. engine displ.	16 L	20 L	70 L	300 L	115 L	150 L
Max. power	21.5 Kw	26 Kw	30 Kw	50 Kw	43 Kw	39 Kw
Torque	186.5 Nm	183 Nm	326 Nm	476 Nm	440 Nm	461 Nm
Drive type	Pre-engaged	Inertia & pre-engaged	Inertia & pre-engaged	Inertia & pre-engaged	Pre-engaged	Pre-engaged
Flange	SAE 1, 2/3, 4, 5, special	SAE 1, 2/3, 4, 5, special	SAE 1, 2/3, 4, 5, special	SAE 1, 2/3, 4, 5, special	SAE 1, 2/3, 4, 5, special	SAE 1, 2/3, 4, 5, special
Max work. pressure	10.3 bar	10.3 bar	8.3 bar	10.3 bar	10.3 bar	10.3 bar
Weight	12 Kg	13 Kg	15 Kg	24 Kg	19.5 Kg	20 Kg

## Gas turbines (gearbox)

Simplicity, easy maintenance, and the ability to handle environmental issues like large particles, dirty field gas, and contaminants are the characteristics of TDI Turbostart air starters for gas turbines. These are qualities that TDI continue to develop to this day. With a Turbostart low pressure type, switching from expensive aero derivative starters to Turbostart air starters for gas turbines, is easier than before. The new low pressure models operate on 3,5 bar (50 psi) max pressure enabling a much easier retrofit into existing aero derivative start systems.

### Type 56: *for gas turbines*

The 56 serie is the ideal series to retrofit existing and expensive aero derivative starters used by the major gas turbine OEM's available in standard and low pressure versions. TDI's unique sprag clutch evenly distributes torque across 22 points of contact (compared to three typical systems) which reduces wear by over 400%, extending life, assuring reliability, and eliminating the need for temperamental ramping controls.



## TDI TURBOGUARD™

Your engine has many built-in safeguards, but protection against hydrolock is not one of them. HydroLock occurs when the engine is started with coolant or other fluids in a cylinder. The coolant is driven through the cylinder at very high pressures during the compression cycle. Because liquids do not compress, as the pressure builds, there is no place for it to go causing an internal collision known as hydrolock.

TDI's TurboGuard™ smart starter detects the presence of any type of obstruction in the cylinders during the start sequence and automatically shuts the starting process down before damage occurs, thus preventing a hydrolock incident.

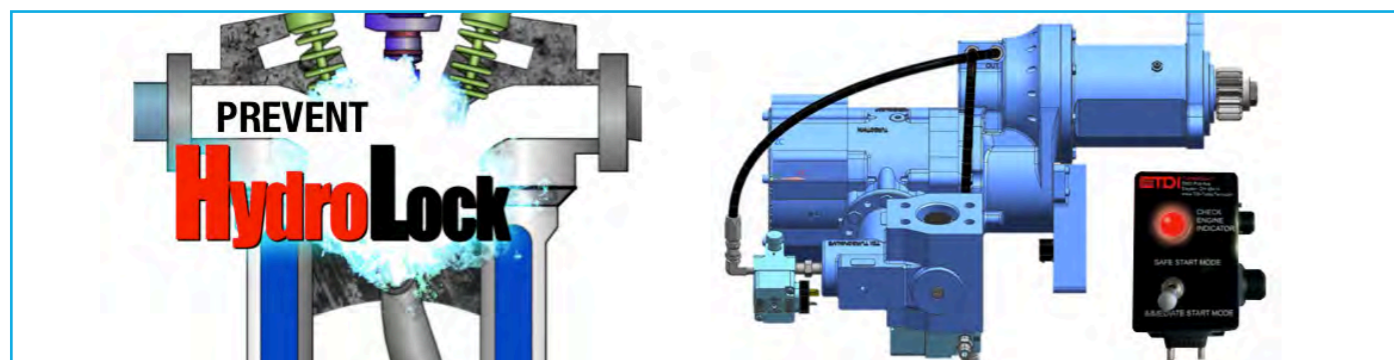

**TDI TURBOGUARD™ provides protection for your engine against hydrolock damage & costly downtime.**

# AIR STARTING SYSTEMS

## TDI TurboValve

TurboValve is a versatile, pilot-operated starting air- or control relay valve used for the installation of TurboTwin air starters. The TurboValve Plus is a completely integrated relay valve with a solenoid that dramatically streamlines the installation process of TurboTwin air starters. Unlike traditional valves where components line-up and orientation issues are a real problem, the indexed mounting of TurboValve Plus assures a clean, consistent placement every time without tightening or over-tightening of the valve. Simply bolt it on the starter, attach the solenoid wires, connect the two air lines and it's done.



## TDI TurboFlow air regulator

The TDI TurboFlow provides more engine starts on a fixed air volume (tank size) and more powerful starter performance on engines additionally loaded under cranking conditions. Smaller air storage tanks can be used without impacting regulatory compliance. TDI TurboFlow enables a lower stored air pressure, which reduces air compressor wear and costs.

## Benefits

“TurboFlow air regulator significantly impacts air consumption & efficiency”

## Modularity and flexibility

The modular design approach of TDI air starters can be characterized by functional partitioning the starter into reusable modules by means of utilization of well defined (industry standards) interfaces. Besides reduction in engineering-, production- and inventory costs, TDI's modularity offers other benefits like customer flexibility and easy maintenance.

As example: A change in available air- or gas field pressure or volume can easily be adjusted by changing the nozzle configuration of the starter. By means of exchanging mounting flanges, pinions and changing angles of relative components, a starter can be used for different applications.

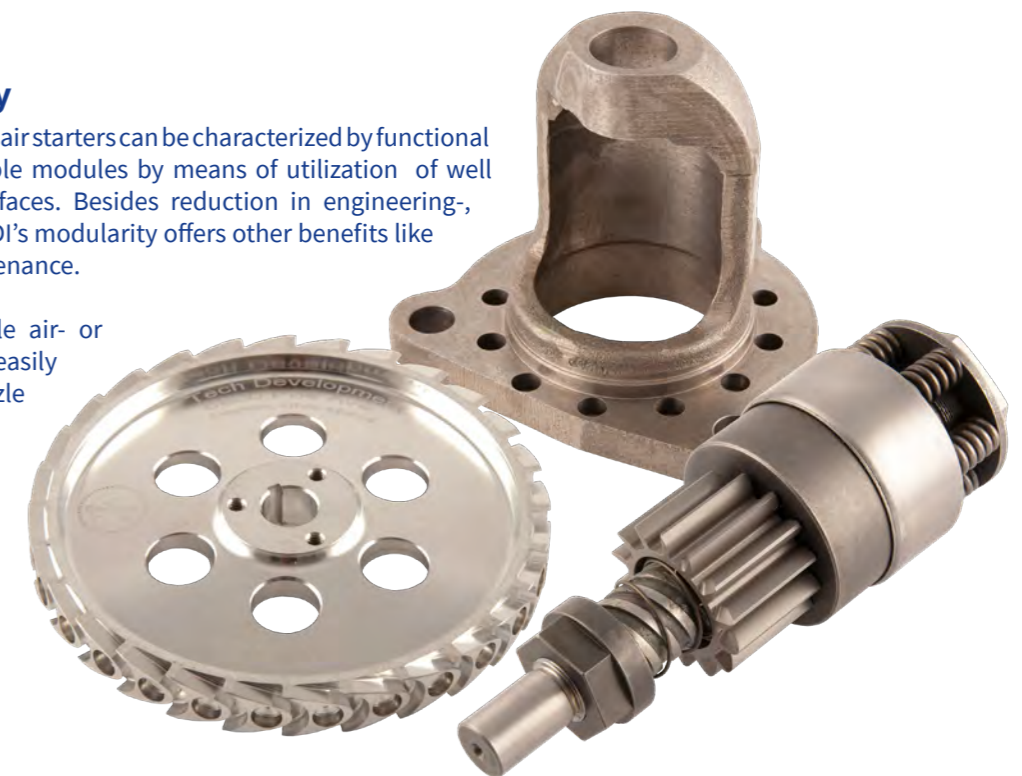

# AIR STARTING SYSTEMS

## The SaveAir system

The SaveAir™ system replaces the existing mechanical or pneumatic air distributor system with an innovative position sensing device (the SaveAir Distributor) to determine the precise angular location of the engine crankshaft. Given accurate radial position data, the SaveAir system electrically actuates air-starting solenoid valves which precisely control both the turn on time of the in head valves as well as the duration of the air admission events during start up. These capabilities enable the SaveAir system to deliver starting air to those cylinders which are most appropriate given the angular position of the crankshaft and virtually eliminating engine starting “dead spots” and to dramatically reduce the amount of air required for the engine start. The SaveAir™ system is a more reliable remote starting, improved operator safety (no mechanical barring), reduced air consumption, and more efficient compressor station operation.

## Benefits

### SaveAir: Air in head starting

- Replaces existing air-in-head starting systems with solid-state microprocessor-based control technology
- Reduces starting air consumption by as much as 70% per start
- Eliminates “dead spots”
- Eliminates manual barring of engine
- Provides more reliable remote starting
- Eliminates failure prone mechanical air start distributor and cam actuated valves
- “Universal” system can be installed on virtually any suitable engine

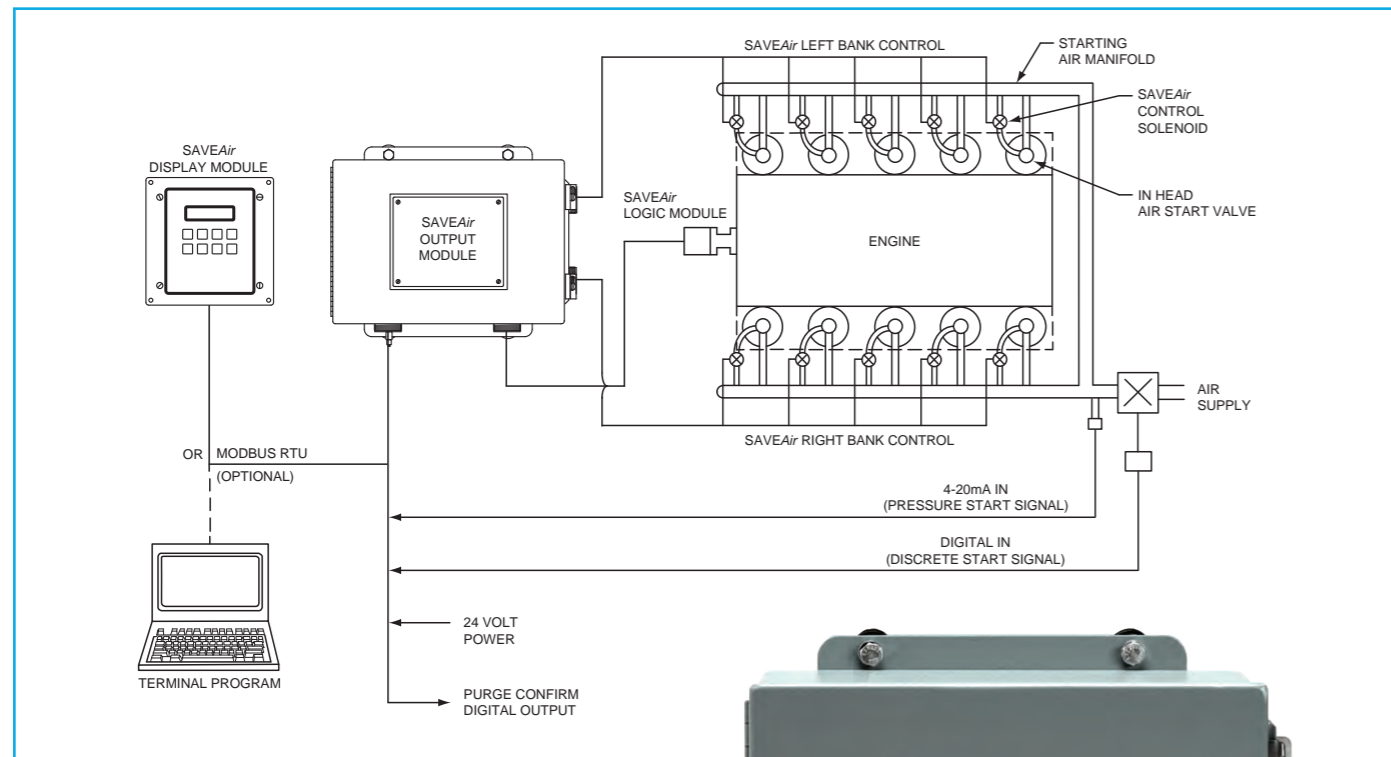

“ Electronic air start system for air-in-head-equipped integral compressor engines ”



# AIR STARTING SYSTEMS

## Things to know about Hatraco air starting systems

### Air starting

Air starting can be applied at applications where compressed air or other starting gas is present under pressure in a sufficient amount. It is a very reliable and clean method of starting an engine. As mentioned at the beginning of this chapter, typically there are two engine air starting methods: Ring gear starting and starting by means of “air-in-head”.

### Reciprocating engines & gas turbines

Supported by Tech development inc. Hatraco supplies air and gas starters for reciprocating engines and gas turbines.

#### Gas turbine starters

OEM, stationary gas turbine engines are often equipped with starter motors designed for flight. TurboStart gas turbine starter motors are specifically designed for (non-flight) stationery gas turbine engines. The manufacturing efficiency for “ground” applications delivers a significantly lower purchase price that is thousands of dollars less than starters designed for flight. The savings also continues in the field. No need for pre-lubricated drive air and the simplicity of the single planetary gear design makes the unit almost maintenance free. Besides of the air/gas driven starter line there is a hydraulic starter line for gas turbines as well. Hatraco supplies gas turbine starters for: GE, Allison, Dresser Rand, Kongsberg, Kawasaki, Pratt and Whitney, Rolce Royce, Solar and Volvo.

#### Reciprocating engine starters

TDI pioneered turbine air starters for reciprocating engines in 1979 by delivering reliable performance in the world’s harshest environments. Their reputation and market share has grown ever since making TDI TurboTwin and TurboStart the most prevalent turbine air starters in the oil and gas industry, on the open waters, at utility power plants, and on mining vehicles around the world.

### Pressure and volume

A benefit of using higher system pressures is that the storage volume can be kept relatively small. Although these pressures are not always obvious in every environment or difficult to maintain. Diesel and gas engines can be already started from pressures as low as 2-4 bar by using the low pressure turbine technology of TDI air starters.

### Product supply

We have the expertise to help you with any type of air starting equipment. We supply your equipment skid mounted, containerized or as stand-alone components according to the project requirements.

### Standards

#### ATEX and CSA

For applications used in explosive atmospheres our air starting systems are available in ATEX and CSA versions according to ATEX MARKING: CE EX II 3 G c T4 (Ta= -34 to 79C) and Class 1, Div 2, Groups C and D.

#### Bureau Veritas, DNV-GL, ABS

All TDI air starters are certified and in compliance with the regulations of the above mentioned parties.



## HATRACO SERVICE



### Hatraco Services

To strive exceeding your expectations during, but also after the sale, Hatraco maintains a staff of professionals who take care of the product or project in any phase of its lifetime. Through the years our company has built a reputation for the highest level of repair work on starting equipment and engine ignition systems. Our engineering, manufacturing and repair processes give our customers excellent quality, knowledge and on-time delivery. Understanding your needs and the importance of providing cost effective and reliable solutions creates the foundation of our values.

### Dealer network

Hatraco has earned a superior position in the market by means of our field services, dealer network and adequate communication in every situation. Through strategic partnerships with equipment manufacturers, committed vendors, support shops and field professionals we continue to extend equipment longevity and reliability with cost-effective results.

### Training & instruction

Training and instruction can be given at the engine on site or in-house by means of demonstration devices that shows all features of the systems.

### Installation and commissioning

Our people will also be there to assist you with installing configuring, programming and finally starting up the engine driven application.



*“ Simple, compact  
and  
dependable ”*



**TOM CLARKE**

Chairman  
*Kineteco*

### Beginnings

Spring starters were developed in 1950s by Simms Engineering, which was formed by Frederick Simms, one of the founders of the motor industry. A close friend of Robert Bosch and Gottlieb Daimler. Later Simms engineering became part of Lucas/CAV. By acquiring the spring starter business from Lucas/CAV back in 1996 Kineteco was formed.

### Global applicability

Kineteco spring starters are used all over the world in many applications powered by a diesel engine. Ships, lifeboats, irrigation pumps, black start generators, mining vehicles just to name a few. We produce a wide range of starters for different engines between 2 and 17 litres. No external power is required for Kineteco spring starters, unlike other starting systems. No modifications are necessary to bolt the spring starters straight on to an engine, due to the universal design based upon common standards.

### Developments

Besides the wide range of starters we offer new models that are engineered and designed by our excellent team. As new engines are released new spring starters are configured by us. Special versions can be configured according to customer requirements. Kineteco “Simms” spring starters are the original spring starters. Simple, compact and dependable. That’s what makes Kineteco unique in the spring starter market.



# SPRING STARTING SYSTEMS

# SPRING STARTING SYSTEMS

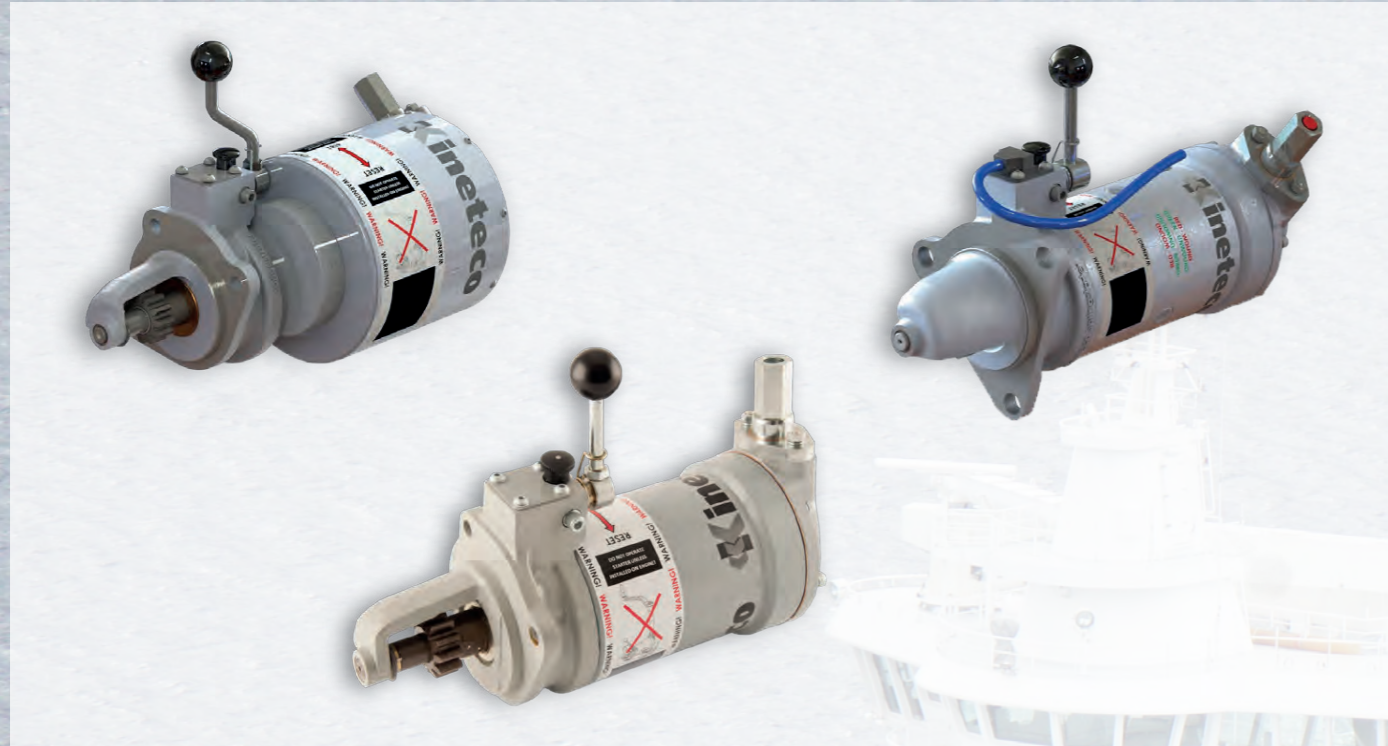

## Mechanical (spring) starting system

Spring starters are spring powered mechanical devices for starting diesel engines, as a replacement or as a redundant starting system allowing an engine to be started easily and safely by hand.

## Kineteco spring starters

Hatraco represents Kineteco spring starters which are suitable for a large range of diesel engines and can start small 400cc single cylinder- all the way up to 17 litre engines. A spring starter requires no external power systems unlike their electric or air (pneumatic) systems. A spring starter is simple, compact, dependable and often a preferred choice for back-up starting.

## Product options

All Kineteco spring starters can be specified as follows:

- F:** Flameproof finish, originally Lloyds Register approved, for use in hazardous environments
- E:** E-pack dual start protection system. For dual starter installations where an electric starter is also used, E-pack prevents simultaneous starter engagement
- M:** Marine build, featuring sealed internals for reliable use at sea

## Kineteco starter ranges by spring type

Two types of springs are used in Kineteco spring loaded starters.

### Disc springs

Disc springs (also referred to as 'Belleville Washers') are conically shaped steel washers which are compressed by means of a ball screw.

Disc spring starter benefits are:

- High output torque
- Robust design



SS disc spring model

### Power springs

Power Springs (also referred to as 'clock' springs) are like a coiled flat steel sheet which is wound up. Power spring benefits for spring starting are:

- High number of output revolutions
- Compact design



SZHS power spring model with Z-drive gearbox

The user winds a spring in the starter using the supplied cranking handle and converts stored potential energy into rotational kinetic energy used to turn over and start the engine. The user can wind the ratched as fast or as slowly as they wish. Once wound, the spring starter can be tripped by pushing a trip lever on the starter when the user is ready and chooses to do so. Using a Kineteco spring starter is safe and easy.

## Benefits

- Efficient
- Reliable
- Versatile
- Convenient
- Standard SAE and special mounting flanges available to fit every engine make and model
- Safe
- Simple and compact
- No external power source necessary
- No maintenance required
- Not affected by cold weather

## Typical applications

### Marine and offshore

- Auxiliary engines
- Emergency gensets
- Propulsion engines (life boats)
- Fire fight pumps (back-up)
- Compressor installations

### Onshore Oil and Gas

- Fire fight pumps
- Black start generators
- Emergency generators
- Compressor installations

### Industry and Utilities

- Black start generators
- Emergency generators
- Compressor installations
- Fire fight pumps (back-up)
- Mobile equipment (explosive atmospheres)

### Agriculture

- Tractors
- Irrigation pumps
- Generators

### Mining

- Transporters
- Drilling equipment
- Pumps

### Military

- Black start generators
- Emergency generators
- Fire fight pumps
- Mobile equipment

# SPRING STARTING SYSTEMS

## Spring Starters



**SMS/SMR:** For engines up to 4 litres

SMS/SMR power spring starters are ideal for smaller engines working in tough conditions. Designed for engines from 0.6 litres to 4 litres displacement, they are perfect for easy and safe hand starting. Using a power spring (rather than a disc spring) makes the body of the SMS/SMR range shorter and lighter. This allows it to be fitted to a wide range of previously incompatible engines.

**SZS/SZR:** For engines up to 4 litres

SZS/SZR spring starters are ideal where engine clearance or low flywheel inertia (common on modern engines) is a problem. With its flexible Z-drive gearbox, the SZS/SZR series can be configured to give greater engine clearance.



**SS/SR:** For engines up to 6 litres

The original pre engaged spring starter with standard duty disc springs. Rugged, reliable with a guaranteed 5.000 start lifecycle. Versatile for all environments. Available with all additional features.

**HSS/HSR:** For engines up to 9 litres

This spring starter uses a set of powerful disc springs that are compressed as the winding handle is turned. The pinion is pre-engaged with the ring gear, and when the starter is tripped, the shaft is released to transmit the power of the spring into the engine. This spring starter delivers higher torque and long life.



**SZHS/SZHR:** For engines up to 15 litres

SZHS/SZHR spring starters are designed for engines from 1.25 litres to over 2 litres/cylinder, but are compact and flexible enough to fit smaller, difficult to start engines. With its flexible Z-drive gearbox, the SZHS/SZHR series can be configured to give greater engine clearance.



**SZH+:** For engines up to 15+ litres

The latest spring starter model: SZH+ have the capability of starting engines from 9 up to 15+litres. They feature all the benefits of the SZH range but with 50% more power, gaining only 70mm extra length on the SZHS/SZHR models. The Z-drive gearbox can be configured to give greater engine clearance.

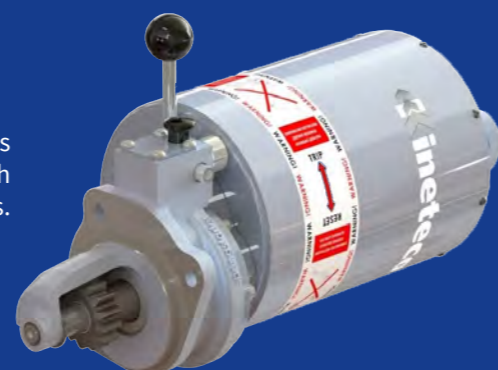

# SPRING STARTING SYSTEMS

## Spring starter specifications

An overview of Kineteco spring starter models:

TYPE	SMS/SMR	SZS/SZR	SS/SR	HSS/HSR	SZHS/SZHR	SZH+
Max. engine displ.	4 L	4 L	6 L	9 L	15 L	20 L
Max. power	0,95 Kw	0,95 Kw	1 Kw	1,5 Kw	2,51 Kw	3,76 Kw
Max. torque	47 Nm	20 - 73 Nm	95 Nm	126 Nm	30 - 112 Nm	73 - 152 Nm
Drive type	Pre-engaged	Pre-engaged	Pre-engaged	Pre-engaged	Pre-engaged	Pre-engaged
Flange	SAE 1, 2/3, 4, 5, special	SAE 1, 2/3, 4, 5, special	SAE 1, 2/3, 4, 5, special	SAE 1, 2/3, 4, 5, special	SAE 1, 2/3, 4, 5, special	SAE 1, 2/3, 4, 5, special
No. output turns	7	20	3	3	5 - 19	8 - 17
Max. wind turns	20	4.4 - 16	10	10	35	35
Weight	14 Kg	14 Kg	16 Kg	16 Kg	20 Kg	24 Kg

	Clockwise	Counter-Clockwise	Disc Springs	Power Springs	Z Drive Gearbox	High Torque	High output turns
SS	•						
SR		•					
HSS	•		•			•	
HSR		•	•			•	
SMS	•			•			
SMR		•		•			
SZS	•			•	•		
SZR		•		•	•		
SZHS	•			•		•	
SZHR		•		•		•	
SZH+	•	•		•	•	•	

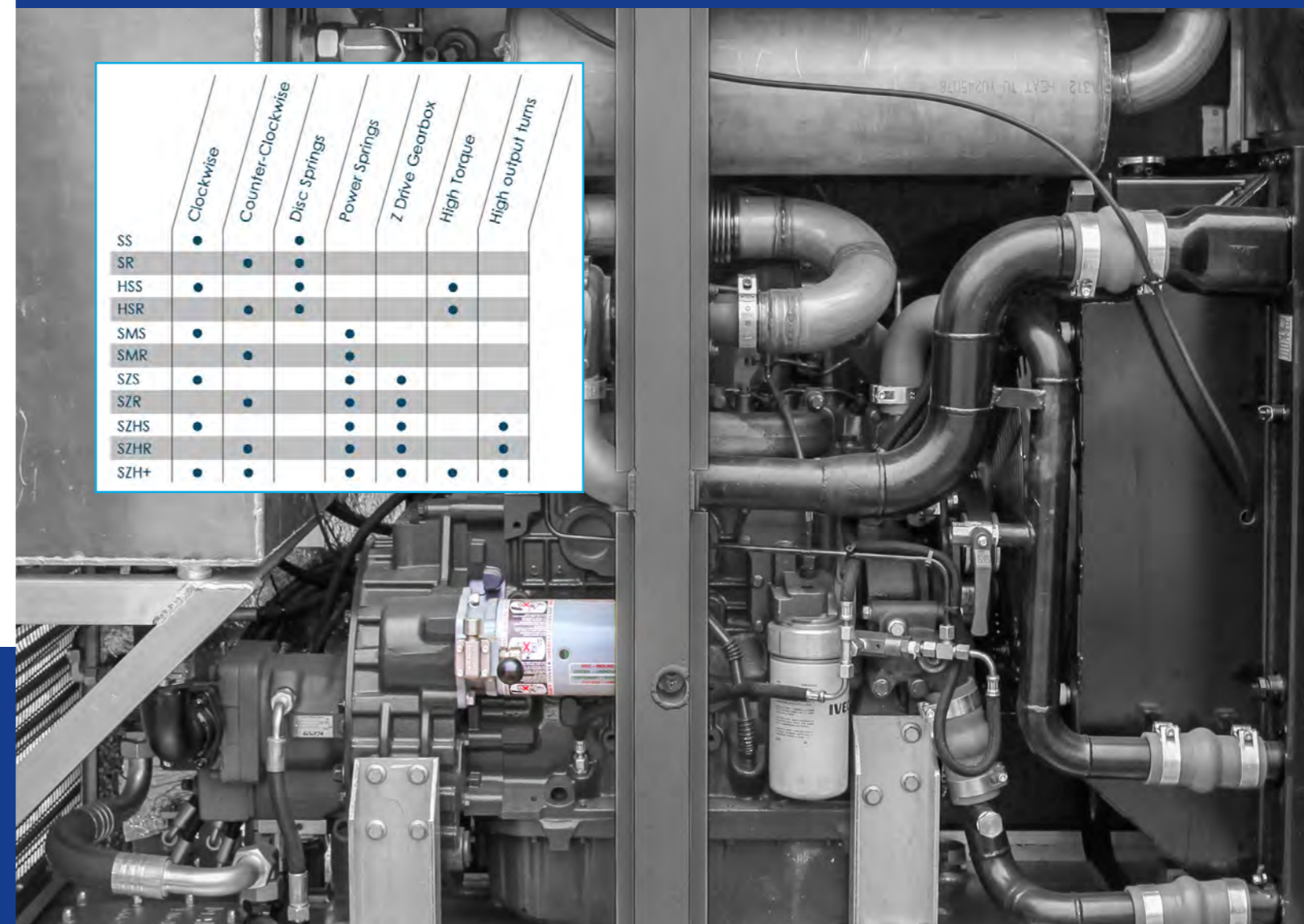

# ELECTRIC STARTING SYSTEMS

## Electric starting

The electric starter motor is the most common type used on gasoline engines and small diesel engines. The modern starter motor is either a permanent-magnet or a series parallel wound direct current electric motor with a starter solenoid (similar to a relay) mounted on it. When current from the starting battery is applied to the solenoid, usually through a switch, the solenoid engages a lever that pushes out the drive pinion on the starter driveshaft and meshes the pinion with the starter ring gear on the flywheel of the engine.



## Bosch & Prestolite electric starters

Hatraco offers a broad range of Bosch and Prestolite starter motors for industrial applications. The Heavy Duty (HD)-starter motors from Bosch and Prestolite are the best solutions for large-volume engines requiring electric cranking power. The starter motors are available in many different configurations, suitable for the majority of industrial engine brands.

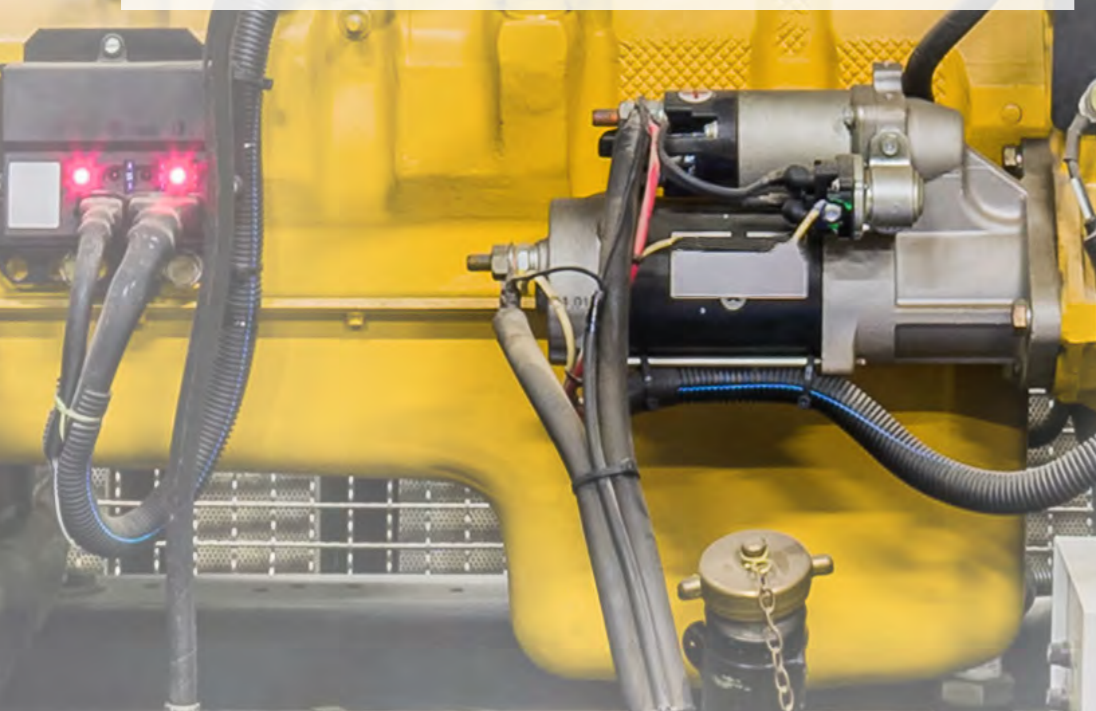

## Typical applications

### Marine and offshore

- Auxiliary engines
- Propulsion engines (*life boats*)
- Fire fight pumps (*FIFI*)

### Onshore Oil and Gas

- Fire fight pumps (*NFPA-20*)
- Gas generators (*CHP*)
- Compressor installations

### Industry and Utilities

- Gas generators (*CHP*)
- Fire fight pumps (*NFPA-20*)
- Mobile equipment

### Agriculture

- Tractors
- Trucks
- Generators

### Mining

- Transporters
- Drilling equipment
- Pumps

### Military

- Fire fight pumps
- Mobile equipment

# ELECTRIC STARTING SYSTEMS

## Product features

A few important features of Bosch electrical starters are listed below.

- Starter motors for 24 volt nominal system voltage
- Starter motor performance of up to 9.2 kilowatts (at -20 °C)
- Powerful solution for diesel engines of up to 28 litres displacement and stationary gas-powered engines
- Six-pole electrically excited starter motor type
- Reduction gear drive and non-sliding overrunning clutch
- Two-stage engagement process
- Unique compact design in this performance class
- B10 lifetime up to 14.000 operating hours
- Integrated mechanical relay (IMR) with optional plug connection provides reliable switching of all starting functions between starter motor and engine control unit
- Modular starter motor concept with optional performance features available

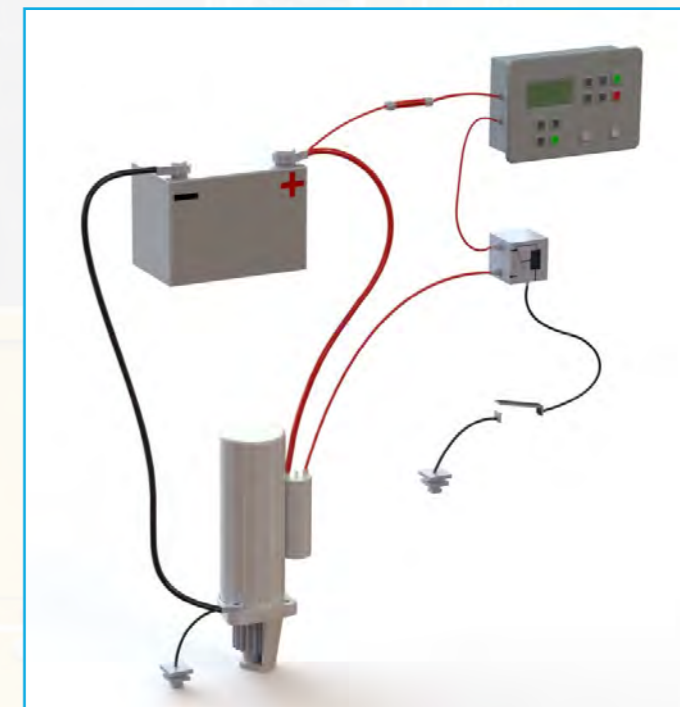

## Bosch

STARTER	HEF109-M	HEF109-MP	HEF109-L
<b>Max. engine displ.</b>	16 L	24 L	28 L
<b>Max. power</b>	7.8 kw	8.4 kw	10 kw
<b>Voltage</b>	24 V	24 V	24 V
<b>Drive</b>	Pre-engaged	Pre-engaged	Pre-engaged
<b>Flange</b>	SAE 1, 2/3, 4, 5 special	SAE 1, 2/3, 4, 5 special	SAE 1, 2,3, 4/5, special
<b>Max. battery</b>	176/790 Din Ah/A	220/900 Din Ah/A	220/900 Din Ah/A
<b>Weight</b>	11.6 Kg	14 Kg	14-17 Kg

**“ Heavy Duty electric starter motor series engineered for high performance demands.”**



**For custom advice, please  
contact our offices.**

### **Europe**

Hatraco  
De Koppeling 3  
6986 CS Angerlo  
The Netherlands

Phone : +31 316 280191  
Fax : +31 316 281161  
E-mail : [sales@hatraco.com](mailto:sales@hatraco.com)  
Internet : [www.hatraco.com](http://www.hatraco.com)

KvK/Trade register No.: 09090953