

YOU'RE IN CONTROL WITH KENCO

OIL LEVEL CONTROLLERS
AND OIL LEVEL SWITCHES



NOW WITH
GROUP B
EXPLOSION
PROOF
RATING



- Reduces maintenance by maintaining a constant oil level
- Protects against lubrication failure
- Controller mechanism fully removable without draining oil.
- Easy view convex sight window
- Low to high pressure applications
- Oil inlet allows for piping configurations from any direction
- Oil outlets on either side of housing and in the bottom to allow for various piping configurations
- Easy access to switch float through 3/8" vent hole in top of housing for simple testing of switch operation
- Direct mount adapters eliminate equalizing problems and reduce installation costs
- Group B explosion proof certification for hydrogen gas environments now available on KLCE/KHL/KSHL/KSL/KES
- Oil level controllers for synthetic oil applications now available

APPLICATIONS

- Stationary engines
- Stationary compressors
- Mechanical lubricators
- Pumps

OPERATING PRINCIPLE FOR OIL LEVEL CONTROLLERS

Kenco oil level controllers are designed to control a constant oil level in the crankcase of stationary engines, compressors, and mechanical lubricator boxes. The Kenco oil controller works in conjunction with an overhead oil supply system which feeds the oil level controller. As the oil is consumed, the oil controller supplies the required oil. The oil controller controls the amount of oil in the crankcase by a float controlled valve. The valve opens and closes as oil is needed in the crankcase to provide a constant oil level.

OPERATING PRINCIPLE FOR OIL LEVEL SWITCHES

Oil level switches are designed as a safety device for the stationary engine or compressor. The oil level switch monitors the oil level in the crankcase. The level within the crankcase directly corresponds with the oil level in the oil level switch housing. The engine or compressor constantly consumes the oil from the crankcase. If the oil level in the crankcase drops past the designated level, the switch will trip and trigger an alarm.

FEATURES

Featured at top: KLCE-48-FS is an oil level controller with an electric switch in an explosion proof enclosure with a direct mounting bracket for an Ariel compressor, with re safe valves.

Featured on cover: KLCE-9-FS is an oil level controller with an electric switch in an explosion proof enclosure with a slotted universal mounting adapter, with re safe valves. A 1618 low ow meter is also installed in this application.

Featured at right: KLCE-24 is an oil level controller with an electric switch in an explosion proof enclosure with a direct mounting bracket for an Ariel compressor.



LOCATION COURTESY OF SCFM COMPRESSION SYSTEMS, TULSA OKLAHOMA

MODEL SPECIFICATIONS

MODEL KLC OIL LEVEL CONTROLLER

Application of Model KLC:

To supply and control the amount of oil in the crankcase.

Standard Materials of Construction:

Valve Seat: Nitrile (Fluorocarbon also available)
Housing and Valve Orifice Material: Aluminum
Float Material: Closed Cell Polyurethane
Oil Inlet Screen: 20 Mesh Brass Cloth
Sight Window: U.V. Stabilized Clear Polycarbonate

Oil Inlet Specifications:

Static Head Pressure Range: 2 –15 Feet
High Pressure Models:
HP-A: 5-35 psi
HP-B: 36-70 psi
Inlet Connection Size: 1/2" FNPT
Outlet Connection Size: 3/4" FNPT

Minimum Flow Rate Test Results:

(Standard unit tested at 32°F, SAE 30)
2' Head: 1.141 GPH
4' Head: 2.122 GPH
7' Head: 2.853 GPH
12' Head: 3.043 GPH
(HP-A Unit Tested at 20°F, SAE 30)
5 psi-0.163 GPH
20 psi-0.266 GPH
(HP-B unit tested at 55°F, SAE 30)
70 psi-0.277 GPH

Also Available:

SYN: Synthetic Oil Applications - Call Kenco with specific gravity of oil used in the application.



MODEL KES ELECTRIC SWITCH IN EXPLOSION PROOF ENCLOSURE; ALSO KHL-ES, KSHL-ES, KSL-ES

Application of Model KES:

The Kenco KES monitors the oil level in the crankcase and signals shut down in case of low oil level. It has no oil level controller function.

Application of Model KHL-ES:

The Kenco KHL-ES is constructed with one level switch, which will alarm at 3/4" above centerline, and will also alarm at 3/4" below centerline.

Application of Model KSHL-ES:

The Kenco KSHL-ES is constructed with 2 independent switches, one for high level alarm 3/4" above centerline and another for low level alarm at 3/4" below centerline.

Application of Model KSL-ES:

The Kenco KSL-ES is constructed with 2 independent switches, for low level trip points of 5/8" and 7/8" below centerline

Standard Materials of Construction:

Housing Material: Aluminum
Float Material: Closed Cell Polyurethane
Sight Window: U.V. Stabilized Clear Polycarbonate

Electric Switch Specifications:

Switch Trip Point: 3/4" Drop
Switch Rating: 15 amp, 125/250/480 VAC
0.5 amp, 125 VDC; 0.25 amp, 250 VDC
1/8 hp, 125 VDC; 1/4 hp, 250 VAC
Max. Temp: 180°F/ 82°C
Electrical Connection Size: 1/2" FNPT
Circuitry: Single Pole Double Throw
Outlet Connection size 3/4" FNPT

Also Available:

DPDT: Double Pole Double Throw Switch
SYN: Synthetic Oil Applications - Call Kenco with specific gravity of oil used in the application.



Class I, Div. I, Div. II,
Groups B, C and D
Hazardous Locations



MODEL KPS – PNEUMATIC OIL LEVEL SWITCH

Application of Model KPS:

To monitor the oil level in the crankcase and to signal or shut down in case of low oil level. Remote or offshore locations with no electric power.

Standard Materials of Construction:

Housing - Aluminum
Float Material - Closed Cell Polyurethane
Sight Window - Clear Polycarbonate (UV stabilized)
Valve - Stainless Steel

Pneumatic Switch Specifications:

Switch Trip Point: 3/4" drop
Maximum Air Valve Inlet pressure - 100psi
Switch Test Button Standard
Air Inlet Connection: 1/4" FNPT
Max. Temp: 180° F/ 82° TC



MODEL SPECIFICATIONS

MODEL KLCM OIL LEVEL CONTROLLER WITH SWITCH IN CSA® TYPE 4 ENCLOSURE

Application of Model KCLM:

The Kenco KLCM utilizes the operating principles of both the oil level controller and the electric switch. The switch may be wired either normally open or normally closed.

Applications:

Intrinsically safe applications with an approved safety barrier.

Standard Materials of Construction:

Valve Seat: Nitrile (Fluorocarbon also available)
Housing and Valve Orifice Material: Aluminum
Float Material: Closed Cell Polyurethane
Oil Inlet Screen: 20 Mesh Brass Cloth
Sight Window: U.V. Stabilized Clear Polycarbonate

Process Connections:

Inlet Connection Size: 1/2" FNPT
Outlet Connection Size: (3) 3/4" FNPT

Oil Inlet Data:

Static Head Pressure Range: 2 –15 Feet
High Pressure Models-
HP-A: 5-35 psi
HP-B: 36-70 psi

Minimum Flow Rate Test Results:

(Standard unit tested at 32°F, SAE 30)
2' Head: 1.141 GPH
4' Head: 2.122 GPH
7' Head: 2.853 GPH
12' Head: 3.043 GPH
(HP-A Unit Tested at 20°F, SAE 30)
5 psi- 0.163 GPH
20 psi-0.266 GPH
(HP-B unit tested at 55°F, SAE 30)
70 psi- 0.277 GPH

Electric Switch Specifications:

Switch Trip Point: 3/4" Drop
Switch Rating: 10 amp, 125/250 VAC or VDC
Max. Temp: 180°F/ 82°C
Electrical Connection Size: 1/2" FNPT
Circuitry: Single Pole Double Throw
Switch Test Button Standard

Wire Color Code:

Red: Normally Closed
Blue: Normally Open
White: Common

Also Available:

SYN: Synthetic Oil Applications - Call Kenco with Specific Gravity



Class III, Type 4



MODEL KLCE OIL LEVEL CONTROLLER WITH ELECTRIC SWITCH IN EXPLOSION PROOF ENCLOSURE; ALSO KHL/KSHL/KSL

Application of Model KLCE:

The Kenco LCE utilizes the operating principles of both the oil level controller and the electric switch.

Application of Model KHL:

The Kenco KHL is constructed with one level switch, which will alarm at 3/4" above centerline, and will also alarm at 3/4" below centerline.

Application of Model KSHL:

The Kenco KSHL is constructed with 2 independent switches, one for high level alarm 3/4" above centerline and another for low level alarm at 3/4" below centerline.

Application of Model KSL:

The Kenco KSL is constructed with 2 independent switches, for low level trip points of 5/8" and 7/8" below centerline.

Standard Materials of Construction:

Valve Seat: Nitrile (Fluorocarbon also available)
Housing and Valve Orifice Material: Aluminum
Float Material: Closed Cell Polyurethane
Oil Inlet Screen: 20 Mesh Brass Cloth
Sight Window: U.V. Stabilized Clear Polycarbonate

Process Connections:

Inlet Connection Size: 1/2" FNPT
Outlet Connection Size: (3) 3/4" FNPT

Oil Inlet Data:

Static Head Pressure Range: 2 –15 Feet
High Pressure Models-
HP-A: 5-35 psi
HP-B: 36-70 psi

Minimum Flow Rate Test Results:

(Standard unit tested at 32°F, SAE 30)
2' Head: 1.141 GPH
4' Head: 2.122 GPH
7' Head: 2.853 GPH
12' Head: 3.043 GPH
(HP-A Unit Tested at 20°F, SAE 30)
5 psi- 0.163 GPH
20 psi-0.266 GPH
(HP-B unit tested at 55°F, SAE 30)
70 psi- 0.277 GPH

Electric Switch Specifications:

Switch Trip Point: 3/4" Drop
Switch Rating: 15 amp, 125/250/480 VAC
0.5 amp, 125 VDC; 0.25 amp, 250 VDC
1/8 hp, 125 VDC; 1/4 hp, 250 VAC
Max. Temp: 180°F/ 82°C
Electrical Connection Size: 1/2" FNPT
Circuitry: Single Pole Double Throw



Class I, Div. I, Div. II
Groups B, C & D
Hazardous Locations



Also Available:

DPDT: Double Pole Double Throw Switch
SYN: Synthetic Oil Applications - Call Kenco with Specific Gravity of oil used in the application.

MODEL SPECIFICATIONS

MODEL 512 OIL LEVEL CONTROLLER WITH CASE TO GROUND ELECTRIC SWITCH CONTACT AND MOUNTING SLOTS ON BACK OF HOUSING

Application of Model 512:

The Kenco 512 is an oil level controller with a case to ground electric switch contact for non-hazardous locations. It is also used in locations where space is limited. Mounting slots allow for adjustment of 2 9/16".

Standard Materials of Construction:

Valve Seat: Nitrile (Fluorocarbon also available)
Housing and Valve Orifice Material: Aluminum
Float Material: Closed Cell Polyurethane
Screen: 20 Mesh Brass Cloth Sight

Oil Inlet Specifications:

Static Head Pressure Range: 2–12 Ft.
No high pressure models available

Minimum Flow Rate Test Results:

(Tested at 30°F with SAE 40)
2' Head-10 Gallons per day

Electric Switch Specifications:

Switch Trip Point Range: 3/16" to 1/2"
Switch Rating: 2 amp, 30 VAC or VDC
Max. Temp: 180°F/ 82°C
Electrical Connection Size: 1/2" FNPT
Circuitry: Case to Ground

slots allow for adjustment of 2 9/16 "
1/2" FNPT side outlet ports
(also 3/4" FNPT bottom port)



MODEL KLCP OIL LEVEL CONTROLLER WITH PNEUMATIC SWITCH

Application of Model KLCP:

The Kenco KLCP utilizes the operating principles of both the oil level controller and the electric switch

Applications:

Remote or offshore locations with no electric power

Standard Materials of Construction:

Valve Seat: Nitrile (Fluorocarbon also available)
Housing and Valve Orifice Material: Aluminum
Float Material: Closed Cell Polyurethane
Oil Inlet Screen: 20 Mesh Brass Cloth
Sight Window: U.V. Stabilized Clear Polycarbonate

Oil Inlet Data:

Static Head Pressure Range: 2-15 Feet
High Pressure Models-
HP-A: 5-35 psi
HP-B: 36-70 psi

Process Connections:

Inlet Connection Size: 1/2" FNPT
Outlet Connection Size: (3) 3/4"

Minimum Flow Rate Test Results:

(Standard unit tested at 32°F, SAE 30)
2' Head: 1.141 GPH
4' Head: 2.122 GPH
7' Head: 2.853 GPH
12' Head: 3.043 GPH
(HP-A Unit Tested at 20°F, SAE 30)
5 psi- 0.163 GPH
20 psi-0.266 GPH
(HP-B unit tested at 55°F, SAE 30)
70 psi- 0.277 GPH

Pneumatic Switch Specifications:

Switch Trip Point: 3/4" Drop
Maximum Air Valve Inlet Pressure: 100 psi
Max. Temp: 180°F/ 82°C
Air Inlet Connection: 1/4" FNPT

Also Available:

SYN: Synthetic Oil Applications - Call Kenco with Specific Gravity of oil used in the application.



MODEL DIMENSIONS

MODEL KLCE /KHL /KSLL /KSHL / KES OIL LEVEL CONTROLLER WITH ELECTRIC SWITCH IN EXPLOSION PROOF ENCLOSURE

*KES MODEL IS ELECTRIC SWITCH ONLY, KES HAS NO OIL INLET AND NO OIL LEVEL CONTROLLER FUNCTION

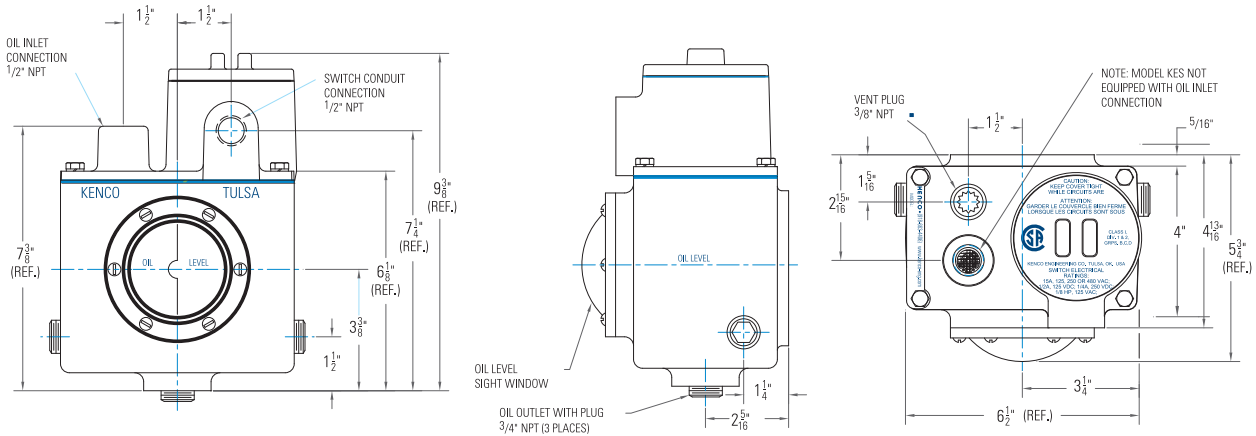

MODEL KLCM OIL LEVEL CONTROLLER WITH SWITCH IN CSA® TYPE 4 ENCLOSURE

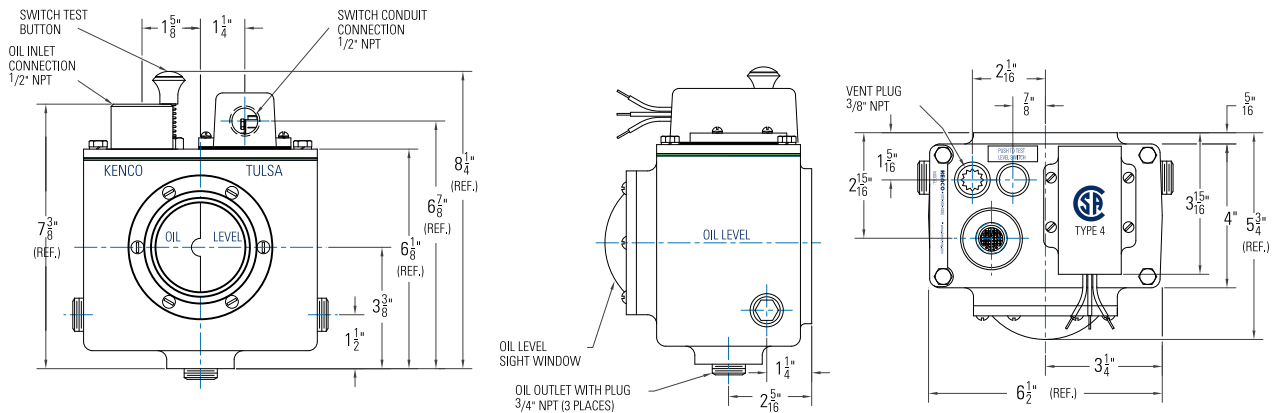

MODEL KLCP OIL LEVEL CONTROLLER WITH PNEUMATIC SWITCH

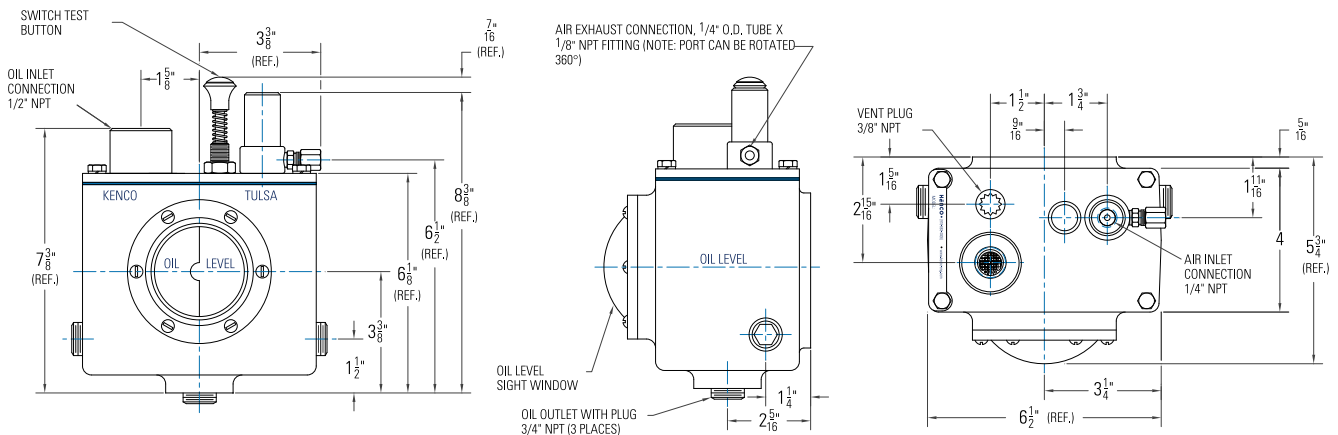

MODEL DIMENSIONS

MODEL 512 OIL LEVEL CONTROLLER WITH CASE TO GROUND ELECTRIC SWITCH CONTACT

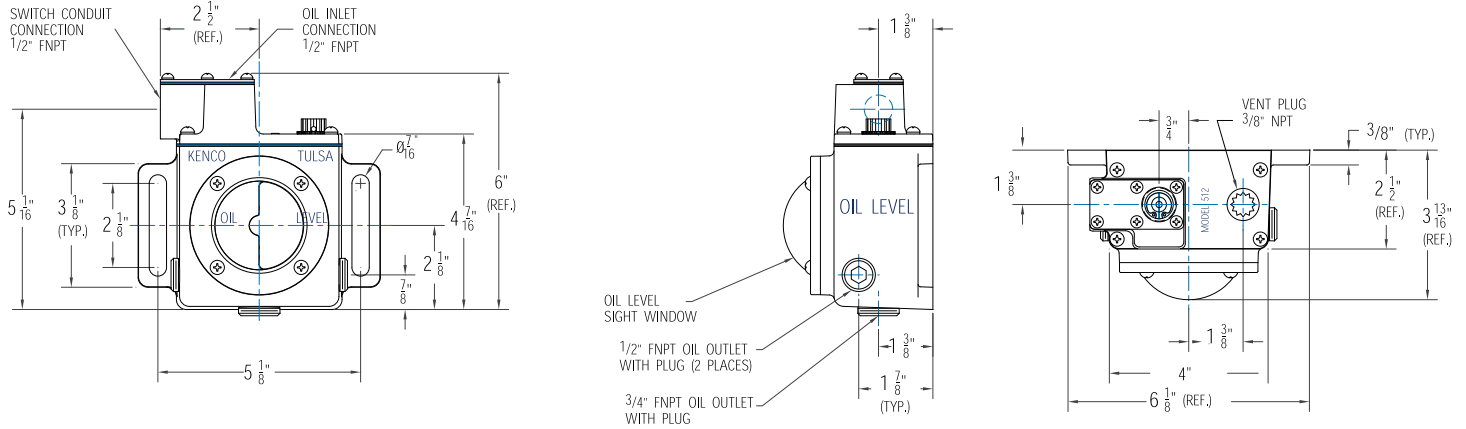

MODEL KLC OIL LEVEL CONTROLLER

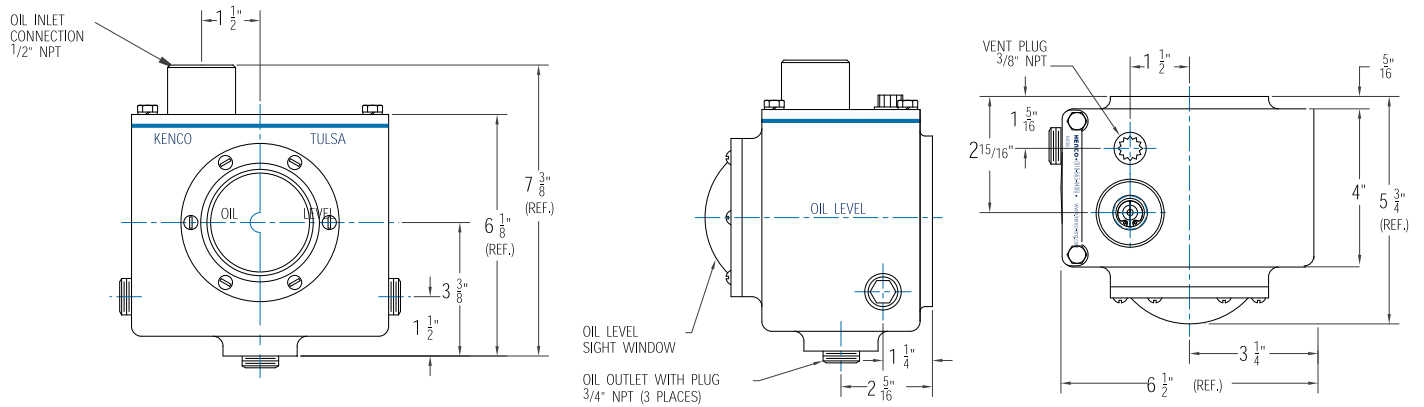

MODEL KPS PNEUMATIC OIL LEVEL SWITCH

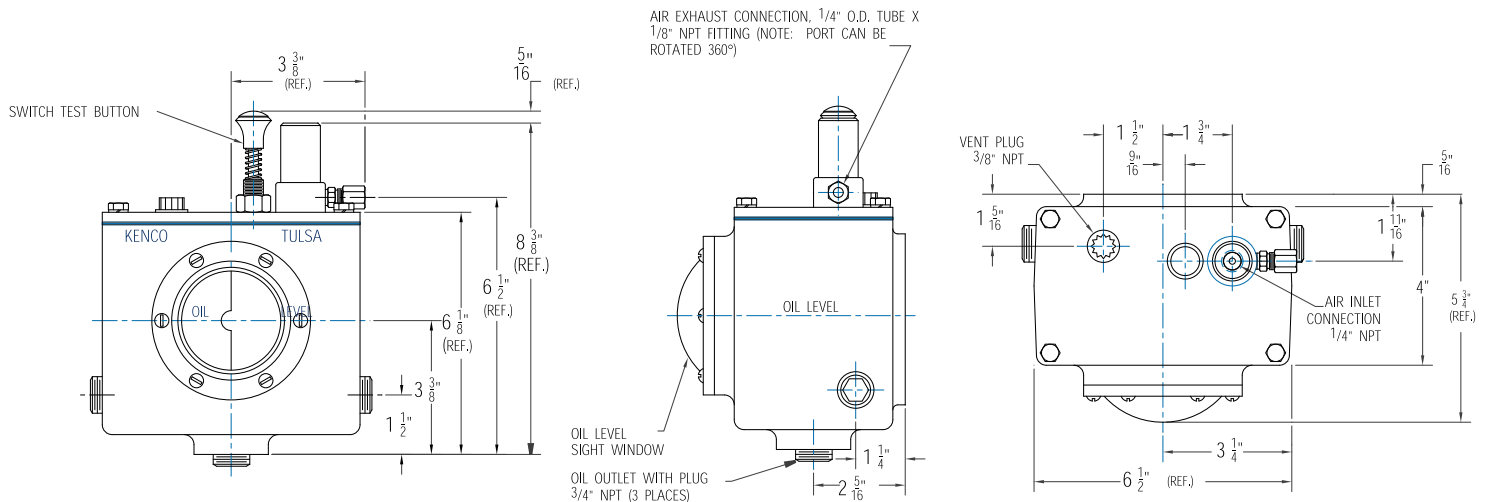

FIRE SAFE VALVES™

U.S. Patent # 3,817,353

OPERATING PRINCIPLE

The Fire Safe Oil Control System provides two spring-loaded, thermally actuated valves. In the event of a fire, valves automatically close, stopping the flow of oil from the crankcase of the engine and the reserve oil supply for the controller. Because the Oil Level Controller will melt during a fire, this prevents the addition of oil from the crankcase and the controller's reserve oil supply to the fire.

BENEFITS

- Lower insurance rates
- Protection in case of fire to equipment
- Protection of personnel
- Protection to environment
- Prevents oil supply from feeding a fire

SPECIFICATIONS

Valve Body – Carbon Steel
Thermal Fuse Melting Temp. – 360°F (other temperatures available upon request)
Spring – Stainless Steel
Valve Plunger – Carbon Steel
Seal Material – Fluorocarbon
Connection Size: 1/2" FNPT or 3/4" FNPT (other sizes available)

TYPICAL INSTALLATION

Inlet Side:

Install the Model 50-FS as close to the controller inlet (or Kenco Oil Flow Meter) as possible

Outlet Side:

Install the Model 75-FS as close to the engine crankcase as possible.

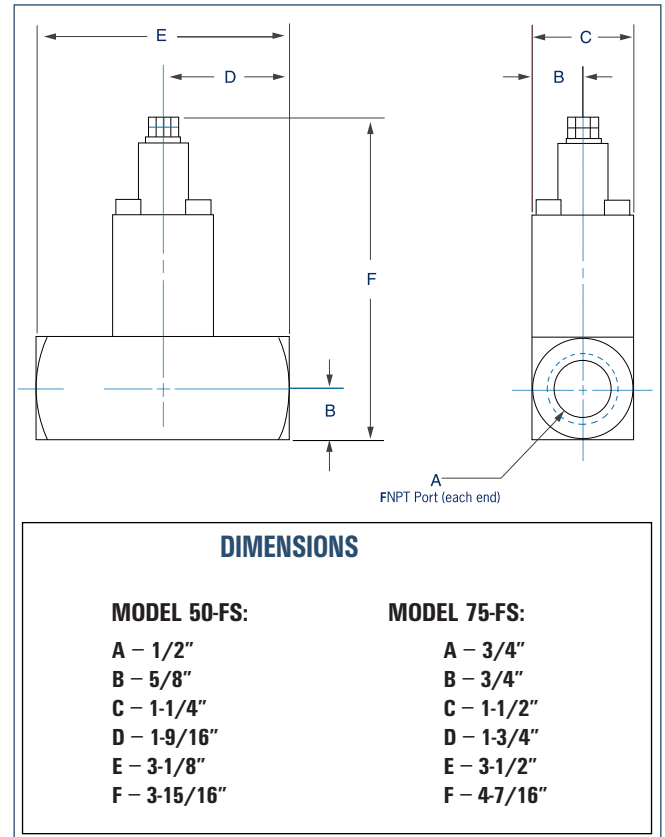

INLET SIDE:

In case of a re stops oil from
owing from oil reserve supply.



OUTLET SIDE:

In case of a re stops backow
of oil from crank case.

REPLACEMENT KITS

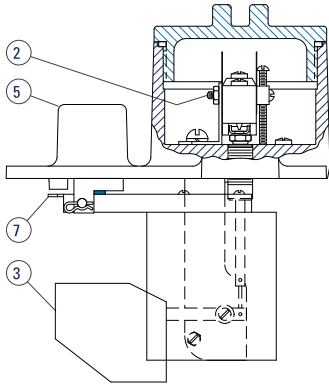

KLCE Replacement Parts Kits

Kit 1: Replacement Kit Of All Working Parts Order #RK-KLCE

- Consists of:
- 1-Complete Cover Plate Assembly As Shown Above
 - 1-Cover Plate Gasket
 - 4-Mounting Bolts
 - 4-Lock Washers
 - 1-Vent Plug

Kit 2: Switch Kit Order #MS-KLCE

- Consists of:
- 1-Switch Assembly With Bracket
 - 1-Switch Bracket Isolator
 - 2-Mounting Screws
 - 2-Lock Washers

Kit 3: Switch Float Kit Order #MF-KLCE

- Consists of:
- 1-Switch Float Assembly With Bracket
 - 2-Mounting Screws
 - 1-Switch Push Rod Retainer Wire

Kit 4: Controller Gasket / Seal Kit Order #GS-KLCE

- Consists of:
- 1-Cover Plate Gasket
 - 1-Sight Window O-Ring Seal
 - 1-Oil Inlet Float Seal
 - 1-Switch Enclosure O-Ring Seal
 - 1-Switch Push Rod O-Ring Seal

Kit 5: Oil Inlet Housing Kit Order #OI-KLCE

- Consists of:
- 1-Oil Inlet Screen
 - 1-Screen Retainer Ring

Kit 6: Controller Housing Sight Window Kit Order #GL-KLC

- Consists of:
- 1-Sight Window
 - 1-Sight Window O-Ring Seal
 - 6-Mounting Screws

Kit 7: Oil Inlet Float Kit Order #OF-KLC

- Consists of:
- 1-Float Assembly
 - 1-Clevis Pin
 - 1-Hitch Pin Clip

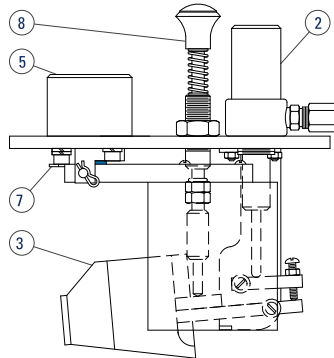

KLCP Replacement Parts Kits

Kit 1: Replacement Kit Of All Working Parts Order #RK-KLCP

- Consists of:
- 1-Complete Cover Plate Assembly As Shown Above
 - 1-Cover Plate Gasket
 - 4-Mounting Bolts
 - 4-Lock Washers
 - 1-Vent Plug

Kit 2: Air Valve Kit Order #AV-KLCP

- Consists of:
- 1-Complete Air Valve Assembly
 - 1-Exhaust Ring
 - 1-Exhaust Ring O-Ring Seal
 - 1-Air Exhaust Connector
 - 1-Actuator Rod

Kit 3: Air Valve Float Kit Order #AF-KLCP

- Consists of:
- 1-Air Valve Float Assembly With Bracket
 - 2-Mounting Screws
 - 2-Hexagon Nuts

Kit 4: Controller Gasket / Seal Kit Order #GS-KLCP

- Consists of:
- 1-Cover Plate Gasket
 - 1-Sight Window O-Ring Seal
 - 1-Oil Inlet Float Seal
 - 1-Oil Inlet Housing O-Ring Seal
 - 1-Air Valve Internal O-Ring Seal
 - 1-Test Button Push Rod O-Ring Seal
 - 1-Air Valve Exhaust Ring O-Ring Seal

Kit 5: Oil Inlet Housing Kit Order #OI-KLC

- Consists of:
- 1-Oil Inlet Screen
 - 1-Screen Retainer Ring
 - 1-Oil Inlet Housing
 - 1-Housing O-Ring Seal
 - 3-Mounting Screws
 - 4-Lock Washers

Kit 6: Controller Housing Sight Window Kit Order #GL-KLC

- Consists of:
- 1-Sight Window
 - 1-Sight Window O-Ring Seal
 - 6-Mounting Screws

Kit 7: Oil Inlet Float Kit Order #OF-KLC

- Consists of:
- 1-Float Assembly
 - 1-Clevis Pin
 - 1-Hitch Pin Clip

Kit 8: Test Button Kit Order #TB-KLCP

- Consists of:
- 1-Complete Test Button Assembly

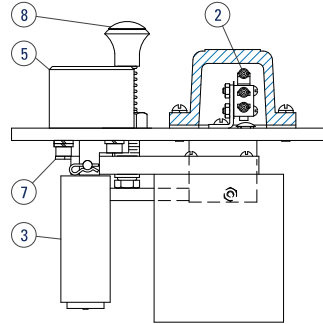

KLCM Replacement Parts Kits

Kit 1: Replacement Kit Of All Working Parts Order #RK-KLCM

- Consists of:
- 1-Complete Cover Plate Assembly As Shown Above
 - 1-Cover Plate Gasket
 - 4-Mounting Bolts
 - 4-Mounting Bolt O-Ring Seals
 - 1-Vent Plug

Kit 2: Switch Kit Order #MS-KLCM

- Consists of:
- 1-Switch Assembly with Bracket
 - 2-Switch Assembly Mounting Screws
 - 1-Switch Enclosure Gasket
 - 4-Switch Enclosure Mounting Screws
 - 4-Lock Washers

Kit 3: Switch Float Kit Order #MF-KLCM

- Consists of:
- 1-Switch Float Assembly With Bracket
 - 2-Mounting Screws
 - 1-Switch Push Rod Retainer Wire

Kit 4: Controller Gasket / Seal Kit Order #GS-KLCM

- Consists of:
- 1-Cover Plate Gasket
 - 1-Sight Window O-Ring Seal
 - 1-Oil Inlet Float Seal
 - 1-Oil Inlet Housing O-Ring Seal
 - 1-Switch Push Rod O-Ring Seal
 - 1-Test Button Push Rod O-Ring Seal
 - 1-Switch Enclosure Gasket
 - 4-Mounting Bolt O-Ring Seals

Kit 5: Oil Inlet Housing Kit Order #OI-KLC

- Consists of:
- 1-Oil Inlet Screen
 - 1-Screen Retainer Ring
 - 1-Oil Inlet Housing
 - 1-Housing O-Ring Seal
 - 3-Mounting Screws
 - 4-Lock Washers

Kit 6: Controller Housing Sight Window Kit Order #GL-KLC

- Consists of:
- 1-Sight Window
 - 1-Sight Window O-Ring Seal
 - 6-Mounting Screws

Kit 7: Oil Inlet Float Kit Order #OF-KLC

- Consists of:
- 1-Float Assembly
 - 1-Clevis Pin
 - 1-Hitch Pin Clip

Kit 8: Test Button Kit Order #TB-KLCM

- Consists of:
- 1-Complete Test Button Assembly

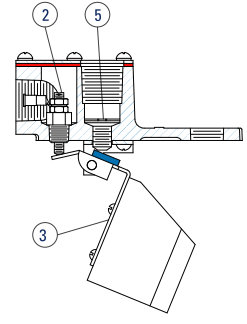

512 Replacement Parts Kits

Kit 1: Replacement Kit Of All Working Parts Order #RK-512

- Consists of:
- 1-Complete Cover Plate Assembly As Shown Above
 - 1-Cover Plate Gasket
 - 4-Mounting Bolts
 - 4-Lock Washers
 - 1-Vent Plug

Kit 2: Switch Kit Order #MS-512

- Consists of:
- 1-Insulator Bushing
 - 1-Set Screw
 - 2-Hexagon Nuts
 - 1-Spade Terminal

Kit 3: Switch Float Kit Order #MF-512

- Consists of:
- 1-Float Assembly
 - 1-Clevis Pin
 - 1-Hitch Pin Clip

Kit 4: Controller Gasket / Seal Kit Order #GS-512

- Consists of:
- 1-Cover Plate Gasket Set
 - 1-Sight Window O-Ring Seal
 - 1-Oil Inlet Float Seal

Kit 5: Oil Inlet Housing Kit Order #OI-512

- Consists of:
- 1-Oil Inlet Screen
 - 1-Screen Retainer Ring

Kit 6: Controller Housing Sight Window Kit Order #GL-512

- Consists of:
- 1-Sight Window
 - 1-Sight Window O-Ring Seal
 - 4-Mounting Screws

IN-LUBRICATOR OIL LEVEL CONTROLLER WITH SAFETY SWITCH

MODEL 507M

The standard valve seat material is Nitrile, but may be ordered as Fluorocarbon for other types of lubrication.

A 1/2" FNPT conduit connection is standard. A basic two wire SPDT switch with form C contacts is standard. The enclosure meets NEMA type 4 classification.



MODEL 507L

The standard valve seat material is Nitrile. A 1/2" FNPT conduit connection is standard. The switch is case to ground, the circuit will remain open until the switch is activated.



APPLICATION

Series 507 Oil Level Controllers are designed for use in Lincoln, Premier, and Mega Lubricators.

OPERATING PRINCIPLE

Series 507 Oil Level Controllers automatically monitor and control the amount of oil in the lubricator housing. This keeps all of the working parts including the pump plungers submerged in oil to reduce wear and corrosion. When the level falls below the operational requirement, the low level safety switch will be activated

FEATURES

- Valve design eliminates lubricator box overflow due to contaminants in the oil
- Controls oil level in lubricator
- Low level safety switch protects against engine and pump repairs due to lubrication failure
- Non-mercury switch will not react to vibration

Model 507M Shown Mounted

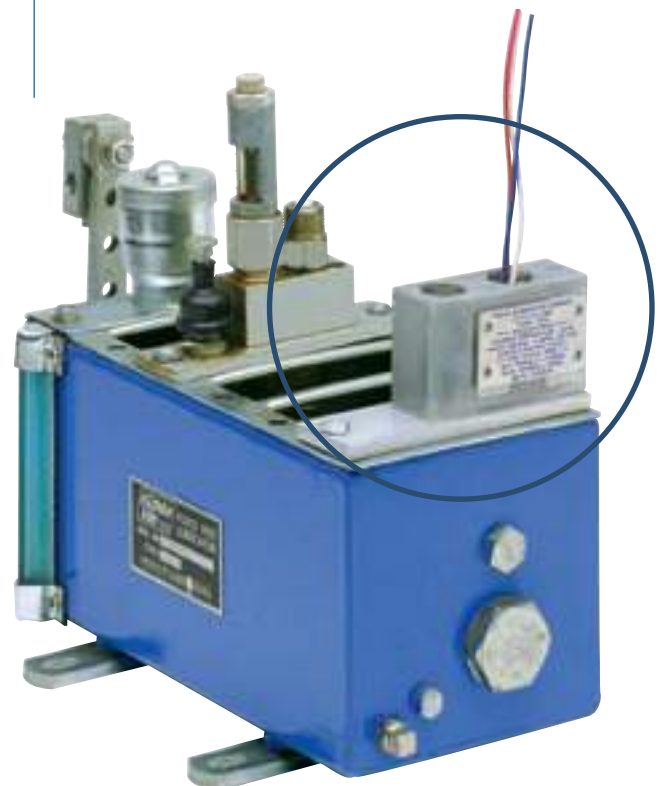

MODEL 507M

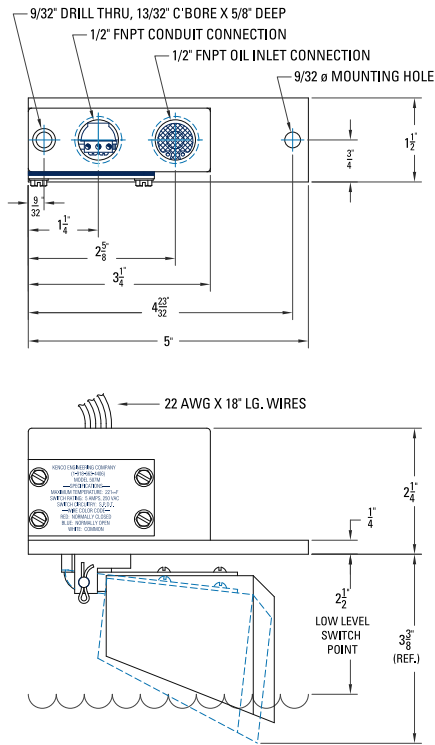

Materials of Construction

Controller Housing - Aluminum
Valve Seat - Nitrile
Optional Valve Seat - Fluorocarbon
(soft seat for synthetic oils)
Valve Orifice - Aluminum
Float Material - Closed Cell Polyurethane
Oil Inlet Screen - 60 mesh brass cloth

Specifications

Switch Trip Point - 3/4" drop in oil level
Switch Rating - 5 amps, 250 VAC or VDC
Electrical Connection - 1/2" FNPT Conduit connection; 22 gauge wire @ 19" long
Wire Color Code:
Red: Normally closed
Blue: Normally open
White: Common
Enclosure - NEMA type 4
Maximum Temperature - 211°F
Inlet Oil Connection - 1/2" FNPT
Circuitry - SPDT
Inlet Pressure - 1' to 14' head of oil
Flow Rate - 2' head @ 32°F,
SAE 30; 1.1413 gallons per hour
Shipping Weight - 15 oz

MODEL 507L

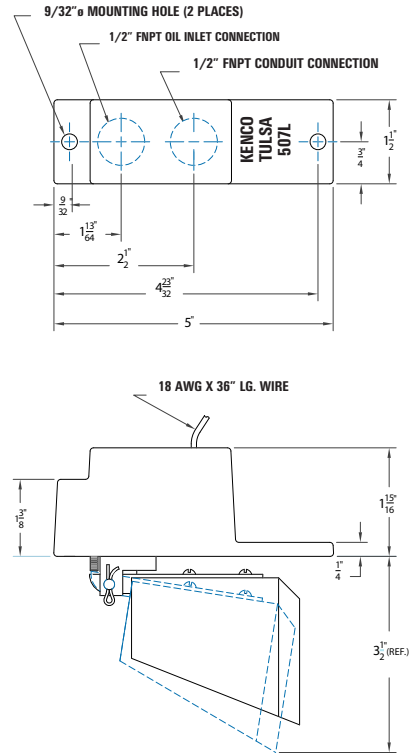

Materials of Construction

Controller Housing - Aluminum
Valve Seat - Nitrile
Optional Valve Seat - Fluorocarbon
(soft seat for synthetic oils)
Valve Orifice - Aluminum
Float Material - Closed Cell Polyurethane
Oil Inlet Screen - 60 mesh brass cloth

Specifications

Switch Trip Point - 3/4" drop in oil level
Switch Rating - 2 amps, 30 VAC or VDC
Electrical Connection - 1/2" FNPT Conduit connection;
18 gauge wire @ 36" long
Maximum Temperature - 211°F
Inlet Oil Connection - 1/2" FNPT
Circuitry - Case to Ground
Inlet Pressure - 1' to 14' head of oil
Flow Rate - 2' head @ 32°F, SAE 30;
1.1413 gallons per hour
Shipping Weight - 15 oz

HIGH-PRESSURE MODELS 507M-HP AND 507L-HP

Inlet Pressure - 5 psi to 60 psi
Minimum Flow Rate - 5 psi @ 32°F, SAE 30; 0.6425 gallons per hour

KENCO ADAPTERS

CONTROLLER TO CRANKCASE MOUNTING ADAPTERS

(Note: ∇ denotes controller mounting surface.)

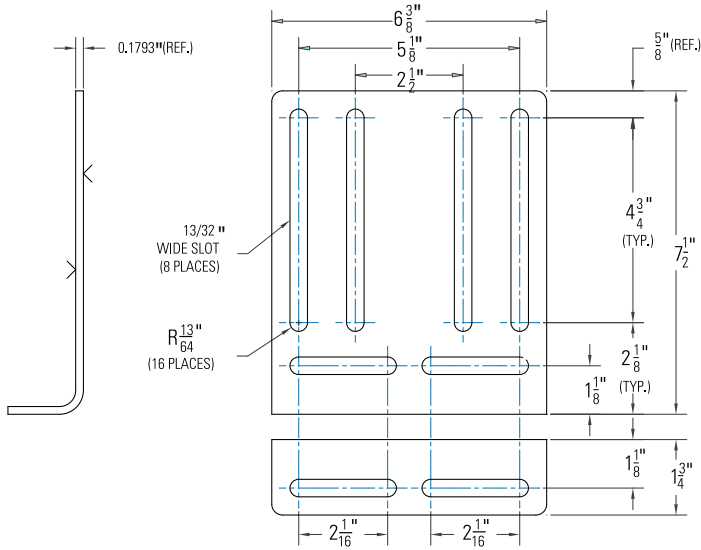

TYPE 9

Universal Mounting Bracket for Any Engine

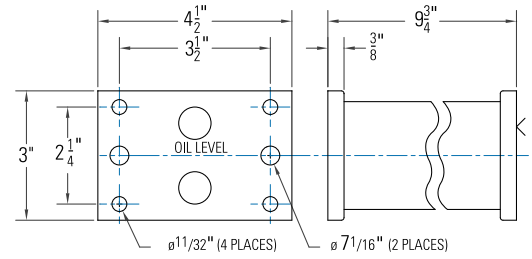

TYPE 24

Mounting Bracket For Ariel
JGE, JGH, JGJ, JGK, JGR, JGT, JGW Compressors

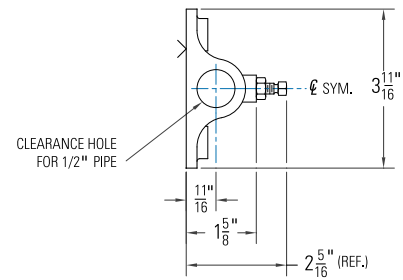

TYPE 11

For Mechanical Lubricator
(Drill 25/32" ϕ holes in lubricator housing to mount)

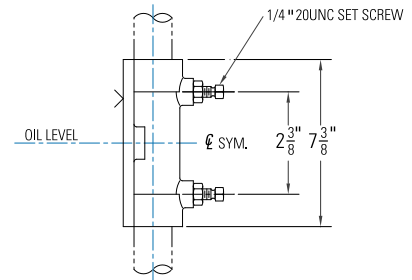

TYPE 12

For 1/2" Pipe

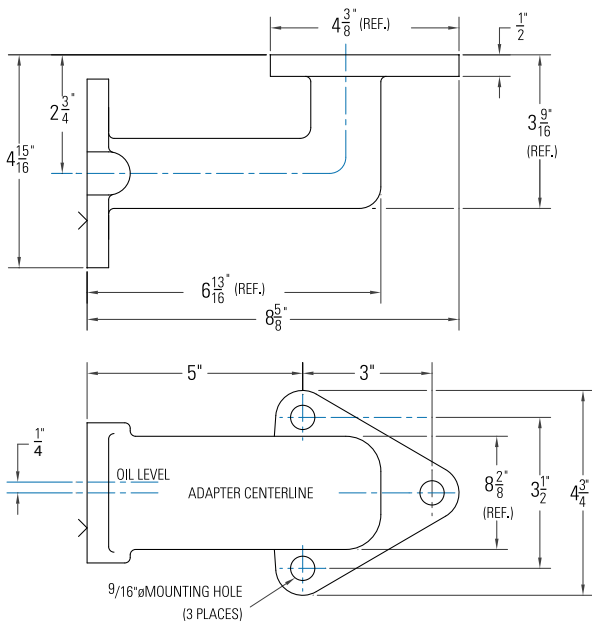

TYPE 14

White Superior Compressor

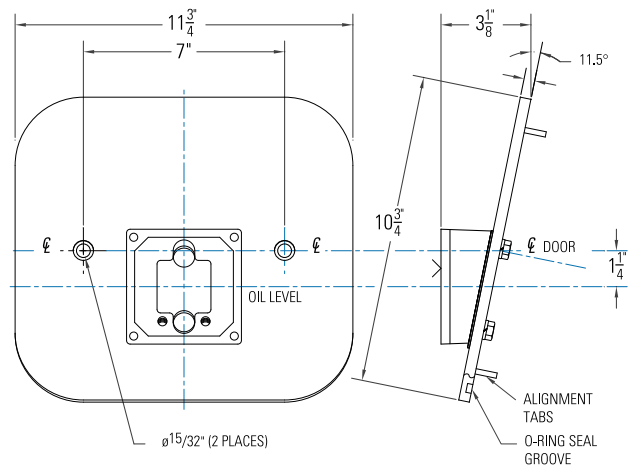

TYPE 27

Waukesha VHP Engine
(Supplied with all mounting hardware/seals)

TYPE 17

Similar to type 27 except for use with old Waukesha engines having inspection door with (1) mounting bolt

KENCO ADAPTER MODEL NUMBERS

ENGINE	NUMBER
Clark MA & CFA	-1
Clark HMB & TMP Compressor	-2
Clark RA, HRA, HBA, HCA, HLA, TLA	-3
Ingersoll-Rand SVG & KVS	-4*
Ingersoll-Rand KVG	-5
Cooper-Bessemer GMW	-6
Cooper-Bessemer GMV	-7
Cooper-Bessemer GMX	-8
Universal Mount Bracket	-9*
LCE Housing with 4 integral mounting studs for use with -9 universal adapter or any mounting configuration which incorporates the stud pattern (does not include universal adapter)	-9MS*
Slotted Adapter Universal Mount for use with 512 oil level controllers	-9U*
Slotted Adapter Universal Mount	-10*
Mechanical Lubricator Mounting	-11
Post Mount For 1/2" Pipe	-12*
White Compressor	-14
Ingersoll-Rand XVG & PVG	-15
Cooper-Bessemer BMW & 275 (Available With Varied Oil Level)	-16
Waukesha VHP Engines F 2895, F3251, F5108, L5790 & L7042 (Replaces Inspection Door)	-17
Waukesha VHP Engines F 2895, F3251, F5108, L5790 & L7042 Door with Low Flow Meter (Replaces Inspection Door)	-18
Ingersoll-Rand Rotary	-19
Cooper-Bessemer 2400 SERIES 6	-21
Ariel JGE, JGH, JGJ, JGK, JGR, JGT, JGW Compressor	-24
Waukesha VHP Engines F 2895, F3251, F5108, L5790 & L7042 (New Style Inspection Door)	-27
Waukesha Inspection Door P 9390	-37
Waukesha Inspection Door P 9390 With Oil Meter	-38
Waukesha VGF L36(12 Cylinder) and P48 (16 Cylinder) Engines	-47
Ariel JGB, JGC, JGD, JGV Compressors	-48
Dresser Rand HOS and VIP(4 and 6 Cylinder) Compressors	-991
Slotted Adapter Universal Mount for Caterpillar 3300/3400 Engines	-C33/34*
512 SPECIFIC ADAPTERS	NUMBER
Fairbanks Morse ZC, 118, 208, 346, 503, 739	512-FM
For Side Mounting On Mechanical Lubricator When There Is No Extra Pump Pocket	512-ML
Mounts On The End Of The McCord Mechanical Lubricator Next To The Filler Cap	512-SML
Witte B,C & F28, F32 & F42	512-W*
Witte 98 With Oil Gauge Bolted To Engine	512-W98*
Arrow C46, C66, C106 AND C245	512-A
Ajax, Lufkin Made Before 1-1-63, Superior And Other Crosshead Type Engines, And Tri-Plex Pumps With 1/2" Drains	512-AJAX
Arrow L-795	512L-795
* Indirect mounted controllers/switches require an equalizing line for proper operation	

TROUBLESHOOTING/COMMON INSTALLATION PROBLEMS

PLEASE REFER TO THE DRAWING BELOW FOR A TYPICAL INSTALLATION OF A KENCO OIL LEVEL CONTROLLER

- Pressure Equalizing Line - Engines or compressors that operate with even the slightest pressure or vacuum in the crankcase require a pressure equalizing line between the controller and the engine crankcase. The pressure equalizing line must be at least 3/8" I.D. tubing. It must be installed so it is self-draining and trap free. Do not place loops in this line because oil traps will prevent pressure equalization.
- Oil Inlet Pressure - Kenco models vary based on oil inlet pressures. The standard unit is good for inlet pressure up to 5 psig. The HP-A model is good for inlet pressures of 5-35 psig. The HP-B model is good for inlet pressures of 36-70 psig. If the correct unit is not installed, the controller will either overfill or not keep up with the engine oil consumption.
NOTE 1: Maximum inlet pressure for 512 models is 4.5 psig.
NOTE 2: Call factory if oil level controller is installed in the line after a low oil consumption meter. Depending on the model of the meter, the oil inlet pressure will change.
- Inadequate Head Pressure - Oil controllers require a minimum of 2' of head pressure.
- Maintained Oil Level in Crankcase - The centerline of the " " in the sight glass should be equal to the centerline of the maintained oil level in the crankcase under normal operating conditions. The controller must be mounted level and plumb.

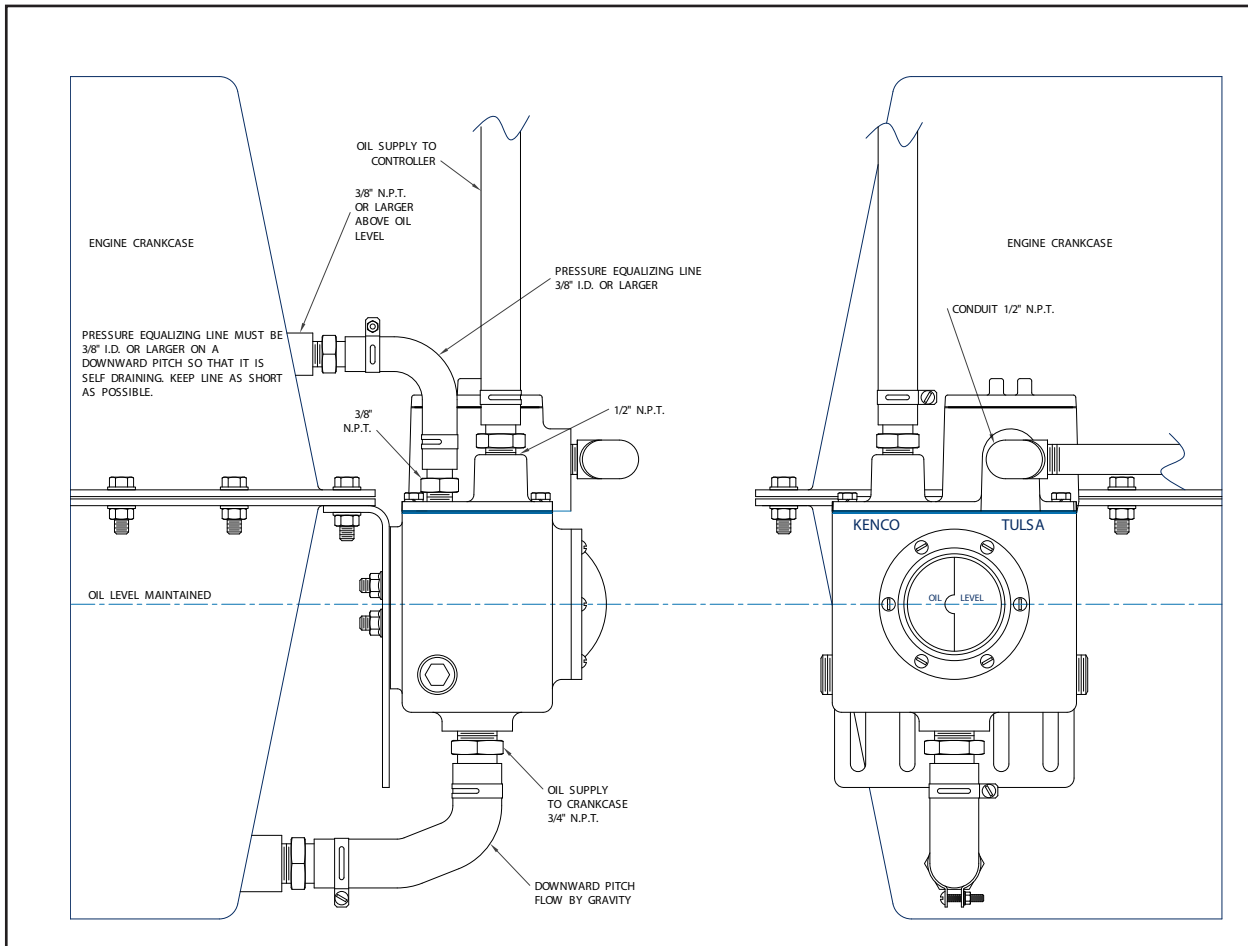

PRODUCT SPECIFICATION SHEET

	KLC	KES	KLCE	KHL	KSHL	KSLL	KLCM	512	KPS	KLCP
FIRE SAFE VALVE	X	X	X	X	X	X	X	X	X	X
STATIC HEAD PRESSURE 2 FT-15 FT	X	X	X	X	X	X	X	-	X	X
STATIC HEAD PRESSURE 2 FT.-12 FT.	-	-	-	-	-	-	-	X	-	-
HIGH PRESSURE OIL INLET 5 –35 PSI	X	-	X	X	X	X	X	-	-	X
HIGH PRESSURE OIL INLET 36 - 70 PSI	X	-	X	X	X	X	X	-	-	X
CONTROLLER WITH 1 SWITCH FOR HIGH/LOW LEVEL	-	-	-	X***	-	-	-	-	-	-
CONTROLLER WITH INDEPENDENT HIGH & LOW LEVEL SWITCHES	-	-	-	-	X*	-	-	-	-	-
CONTROLLER WITH INDEPENDENT LOW/LOW LEVEL SWITCHES	-	-	-	-	-	X***	-	-	-	-
DPDT SWITCHES	-	X	X	X	-	-	-	-	-	-
CSA® CERTIFIED CLASS I DIV. I AND II, GROUPS B,C, D	X	X	X	X	X	-	-	-	-	-
CSA® CERTIFIED TYPE 4 ENCLOSURE	-	-	-	-	-	-	X	-	-	-

X = is available on this model

- = is not available on this model

* = unit constructed with two independent switches, one which will trip at 3/4" above centerline and the second which will trip at 3/4" below centerline

** = unit constructed with two independent switches for trip points at 5/8" or 7/8" below centerline

*** = unit constructed with single switch, which will trip at 3/4" above or 3/4" below centerline

PRODUCT SPECIFICATION SHEET

CONTROLLER DESIGNATIONS

KES	Electric switch in explosion proof enclosure; no oil controller function
KLCE	Oil Level Controller with electric switch in explosion proof enclosure
KHL	Oil Level Controller with one switch in explosion proof enclosure for high level and low level alarm
KSHL	Oil Level Controller with two independent switches in explosion proof enclosure for high level and low level alarm
KSLL	Oil Level Controller with two independent switches in explosion proof enclosure with two low level trip points of 5/8" and 7/8"
KLCM	Oil Level Controller with switch in CSA® Type 4 enclosure
512	Oil Level Controller with case to ground switch contact and mounting slots on back of housing
KPS	Pneumatic switch; no oil controller function
KLCP	Oil Level Controller with pneumatic switch

ORDERING SYSTEM

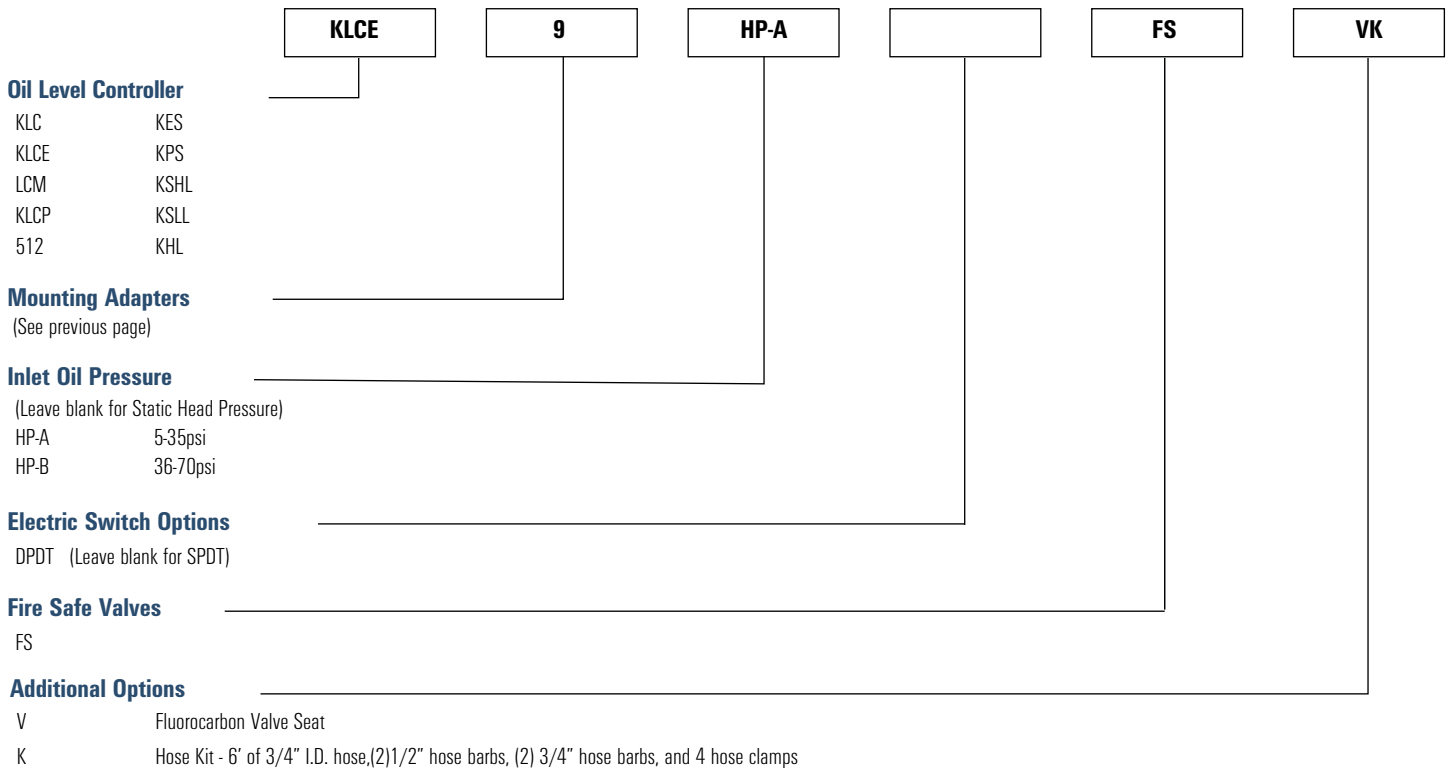

Example shown above: KLCE-9-HP-A-FS-VK is an oil level controller with an electric switch in an explosion proof enclosure, a slotted universal mounting adapter, a high pressure inlet valve good for inlet pressure from 5 to 35 psi, re safe valves, a uorocarbon valve seat, and a hose kit.

Represented by:

Kenco Sales Office:

Tulsa Office

PO Box 470426
Tulsa, OK 74147
phone 918.663.4406
fax 918.663.4480
<http://www.kenco-eng.com>
email: info@kenco-eng.com

Baton Rouge Office

11616 Industriplex, Suite 14
Baton Rouge, LA 70809
phone 225.755.1912
fax 225.755.1913
<http://www.kenco-eng.com>
email: kenco-la@tlxnet.net