



QUADRIFOGLIO

Art 570 400mm Lt.35

Guide Grass • Grass Slides • Glissières Grass • Guías Grass
REV. 00.2016
FOIST00057

Prodotto ed assemblato in Italia / Made and assembled in Italy / Fabriqué et assemblé en Italie / Hecho y montado en Italia

CARATTERISTICHE • FEATURES • CARACTÉRISTIQUES • CARACTERÍSTICAS

Pattumiera ad estrazione totale da 400 mm Lt.35
Full extension wastebin 400 mm Lt.35
Poubelle sortie totale 400 mm Lt.35
Cubo de basura a extracción total 400 mm Lt.35

MINUTERIA INTERNA • FITTINGS • FERRURE • PEQUEÑA CUBIERTA

n°12 3,9x13 Vite autofilettante TC a croce / Self tapping screw TC
Vis autotaraudeuse TC / Tornillo autorroscante TC
n°8 4x16 Vite autofilettante TSP a croce / Self tapping screw TSP
Vis autotaraudeuse TSP / Tornillo autorroscante TSP
n°4 M4x5 Vite cilindrica / Cylindrical screw / Vis cylindrique / Tornillo cilíndrico

COMPONENTI • PARTS • COMPOSANTS • COMPONENTES

A. n°1 Box metallico / Metal box / Boîte en métal / Caja de metal
B. n°1 Coperchio / Lid / Couvercle / Tapa
C. n°1 Kit guide Grass / Kit grass slides / Kit glissières grass / Kit de guías grass
D. n°1 Coppia carter guide / Kit slide cover
Kit carter pour la glissière / Kit carter para las guías
E. n°2 Lamiera reggi coperchio / Metal plate lid holder
Support pour couvercle tôle / Placa de metal para sostener la tapa
F. n°1 Secchio pattumiera 35 Lt. / Wastebin Lt.35 / Poubelle Lt.35 / Cubo de basura Lt.35
G. n°1 Coppia attacco antina / Kit door fixing brackets
Kit pattes de fixation sur la porte / Kit soportes de fijación de la puerta
H. n°2 Squadretti stabilizzatori antina / Door stabilizing elements
Élément de stabilisation de la porte / Elementos para la estabilización de la puerta
I. n°2 Cover attacco antina / Door fixing cover
Carter pour la patte de fixation / Cover para los soportes de fijación
L. n°4 Tappo / Stopper / Bouchon / Tapón

UTENSILERIA • TOOLS
OUTILS • INSTRUMENTOS

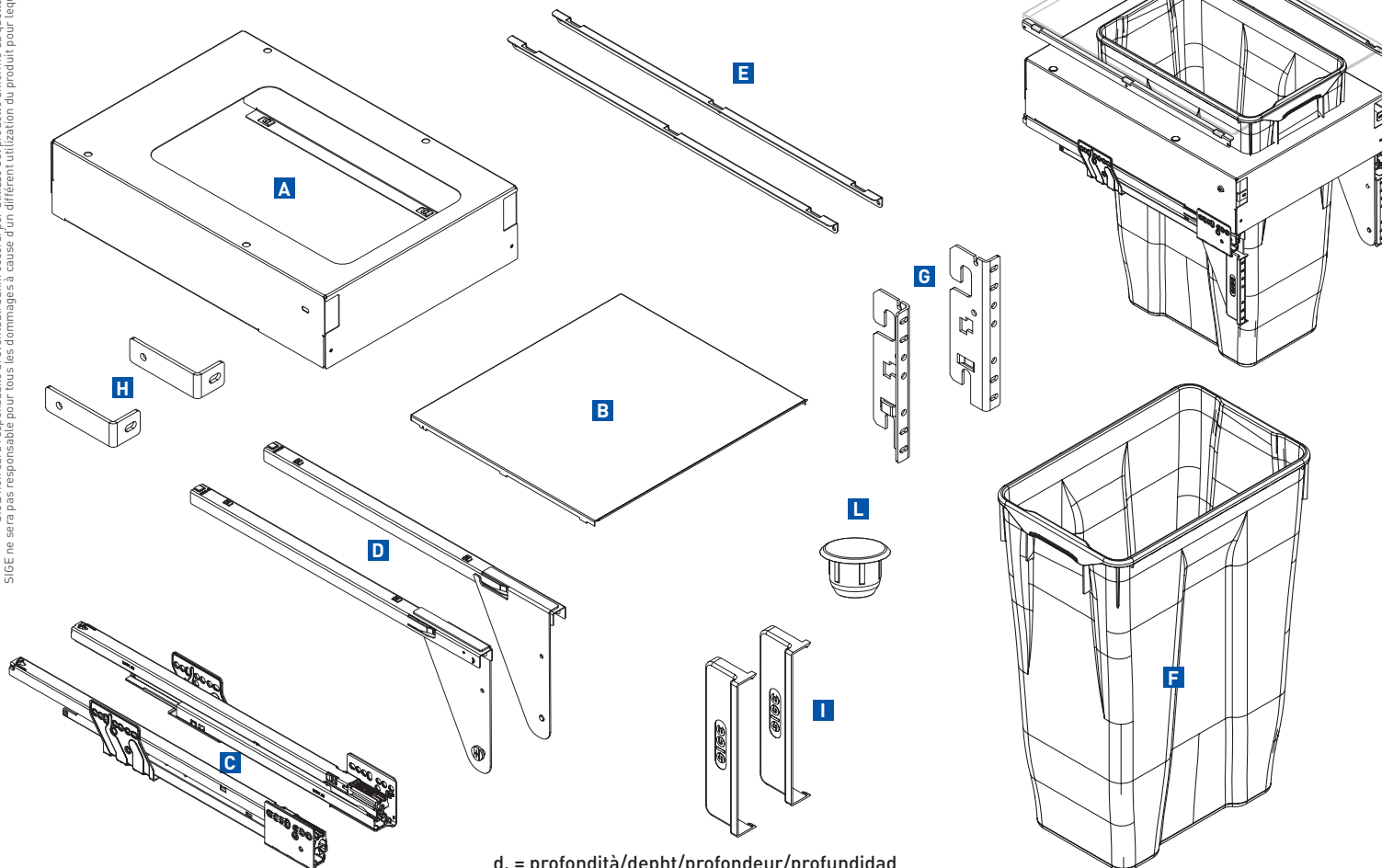
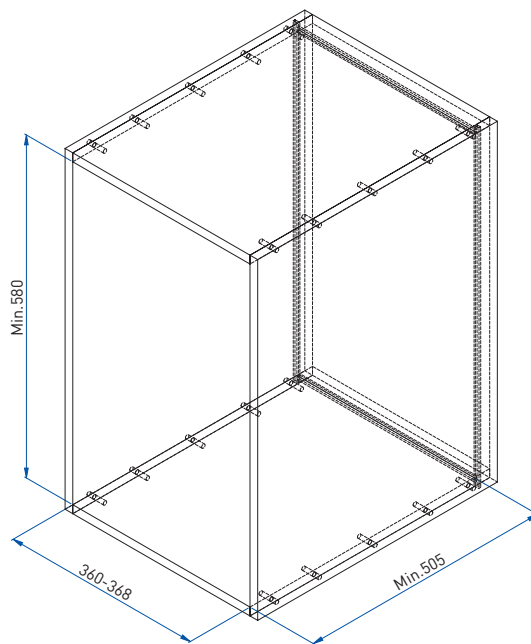

d. = profondità/dept/profondeur/profundidad

SIGE non sarà responsabile di eventuali danni occorsi per utilizzo del prodotto difforme da quello per il quale è stato concepito. SIGE will not be responsible for any eventual damage due to a different use from the one it has been made. SIGE ne sera responsable para cualquier dano debido al uso diferente de lo por el cual un producto ha sido realizado.



1

Fissare le guide C e le lamiera reggi coperchio E rispettando le quote.

Fix the Sige slides C and the metal plate lid holder E according to the dimensions.

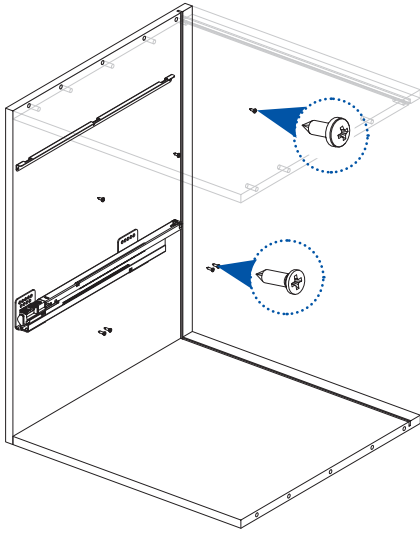

	K
d.450	212
d.500	237

Fixez le kit glissières Sige C et le support pour couvercle tôle E en respectant les dimensions.

Fijar el kit de guías Sige C y la placa de metal para sostener la tapa E respetando las medidas.

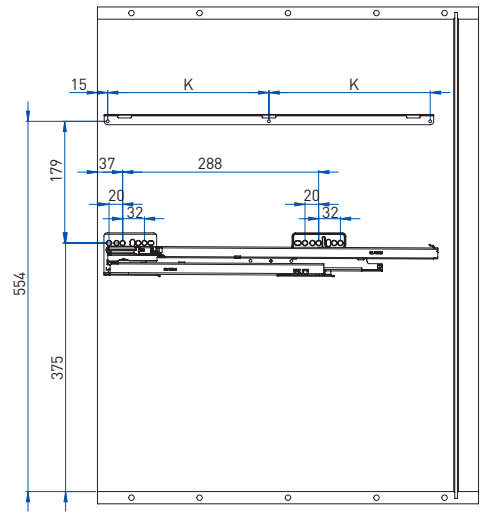

2

Inserire la coppia carter guide D nelle guide C.

Put the kit slide carter D into the Sige slides C.

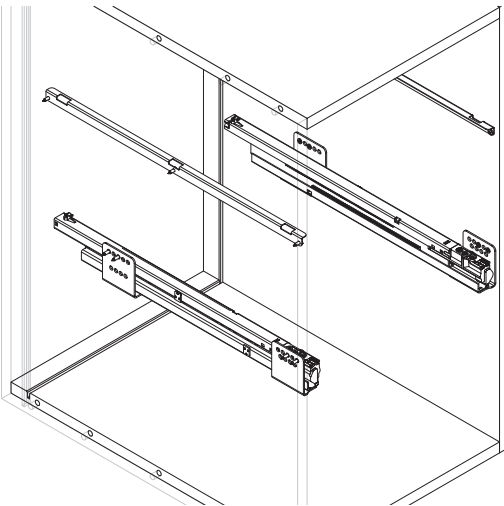

Insérez le kit carter pour la glissière D dans les glissières C.

Colocar el kit carter para las guías D sobre las guías Sige C.

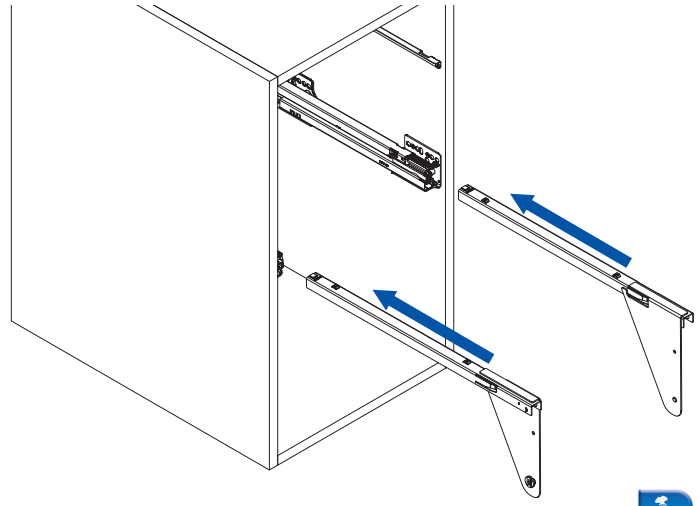

3

Avitare il box metallico A nei carter guide D mediante le apposite viti.

Screw the metal box A into the kit slide carter D by using the specific provided screws.

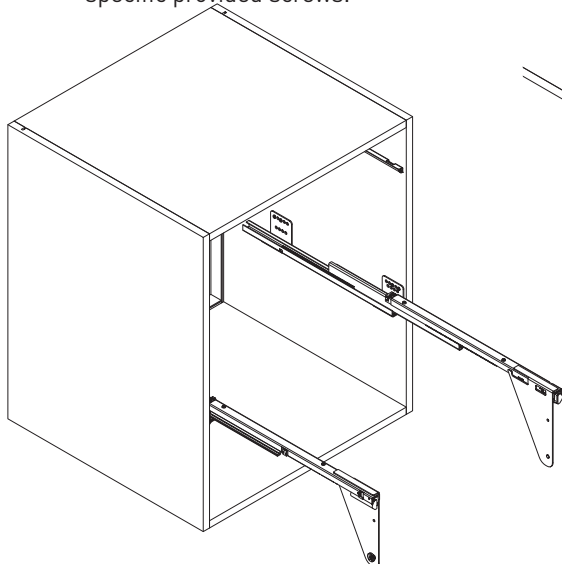

Vissez la boîte en métal A dans le kit carter pour la glissière D avec les spécifiques vis fournies.

Atornillar la caja de metal A en el kit carter para las guías D con los tornillos provistos.

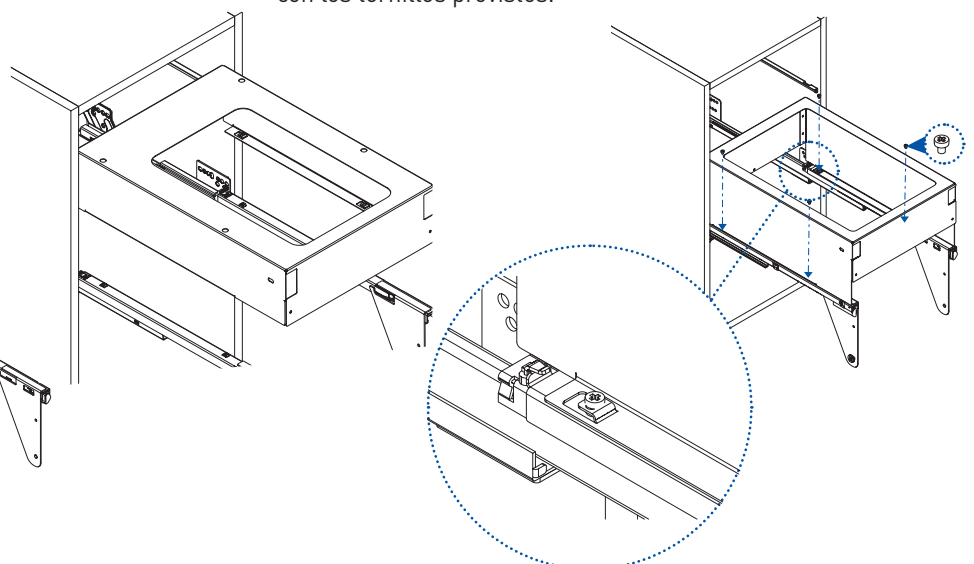

N°4 M4x5



4

Inserire i tappi L.
Insert stopper L.
Insérez les bouchon L.
Introduzca los tapòn L.

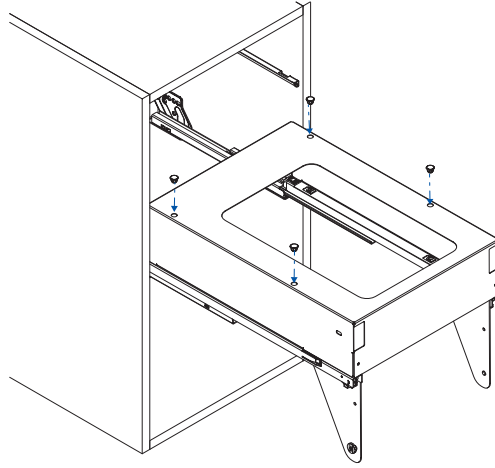

5

Fissare la coppia attacco antina G nell'anta, rispettando le quote.

Assemble the kit door fixing brackets G along with the according to the dimetions.

Fixez le kit pattes de fixation sur la porte G du meuble en respectant les dimensions.

Fijar el kit soportes de fijación de la puerta G en la puerta respetando las medidas.

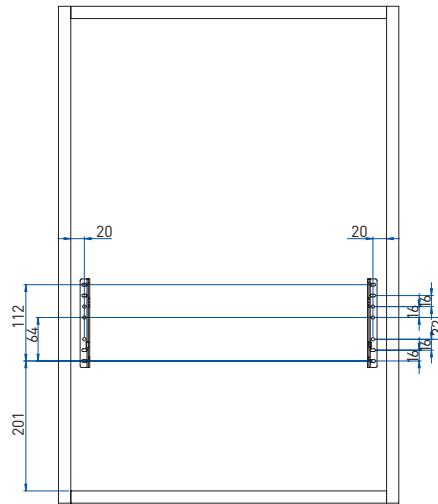

N°6 3,9x13

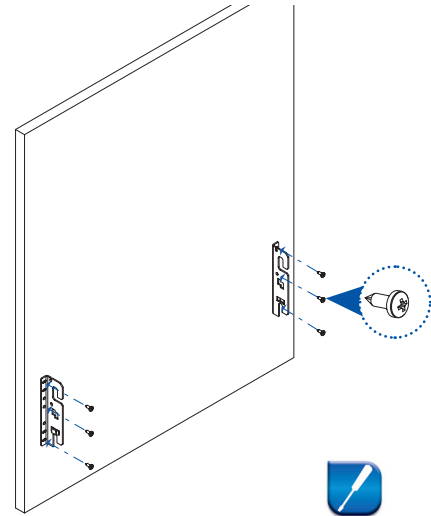

6

Inserire l'antina nei carter D e serrare il tutto a mezzo vite e rondella speciali.

Put the door into the carter D and fix them by using the specific screw and washer.

Insérez le kit carter pour la glissière D et fixez tout avec la vis et la rondelle spécifiques.

Colocar la puerta en los carter D y apretar todo con el tornillo y la arandela específicos.

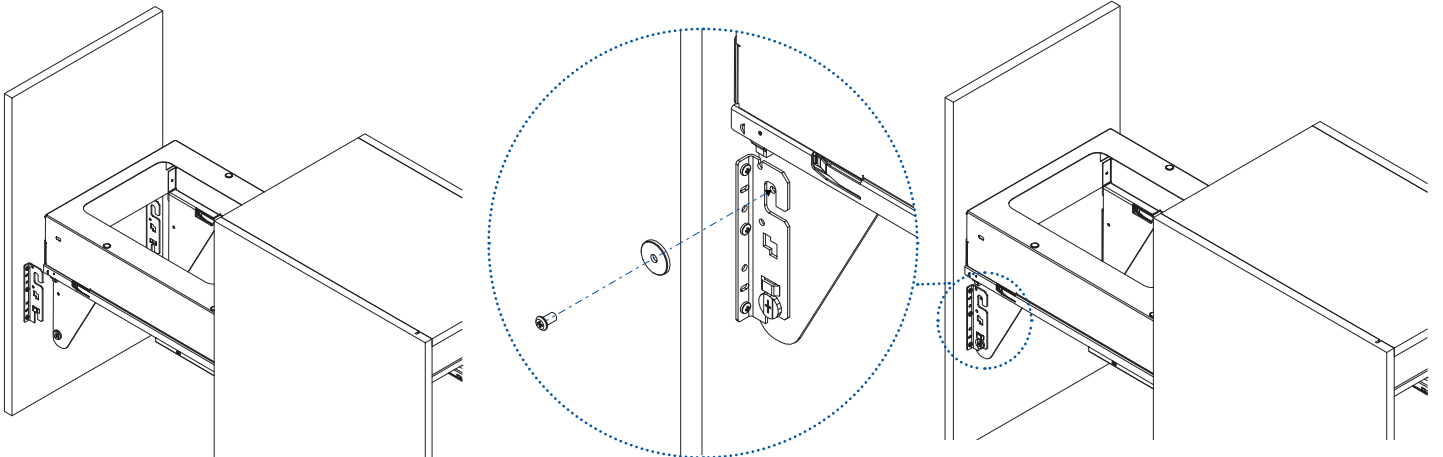

7

Effettuare la regolazione dell'anta.
Adjust the furniture door.
Réglez la porte du meuble.
Ajustar la puerta del mueble.

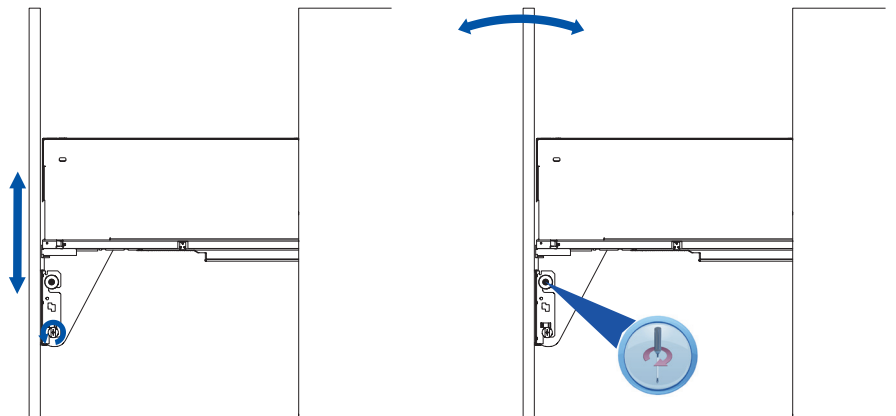



8

Fissare i squadretti stabilizzatori anta H come illustrato dalle foto.

Fix the door stabilising elements H as shown in the pictures.

Fixez les éléments de stabilisation de la porte H comme dans las photo.

Fijar los elementos para la estabilización de la puerta H como se muestra en las imagenes.

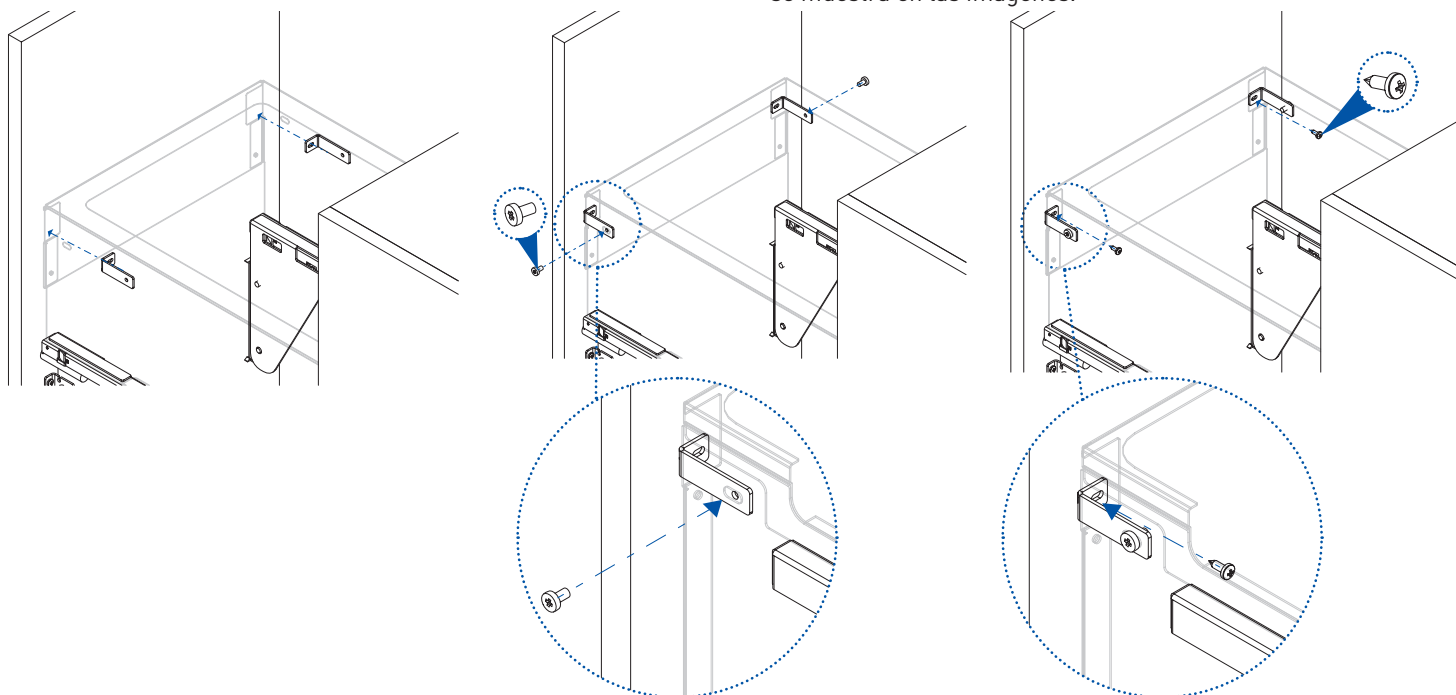

9

Inserire il coperchio B nelle lamiere reggi coperchio E e inserire la pattumiera F.

Put the lid B into the metal plate lid holder E and insert the wastebin F.

Insérez le couvercle B sur le support pour couvercle tôle E et insérez aussi la poubelle F.

Poner la tapa B sobre la placa de metal que sostiene la tapa E y colocar también el cubo de basura F.

