

BEAUHOMIE

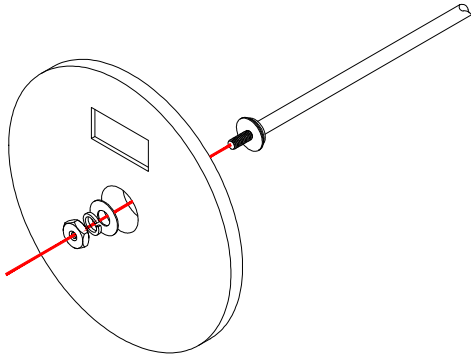

PORTABLE CLAMPLAMP-ROUND

FIGURE 01



IMPORTANT SAFETY INSTRUCTIONS:

- For safety purposes, this lamp is equipped with a polarized plug (one blade is wider than the other).
- If the plug does not fit securely into outlet, do not force it - contact a professional electrician.
- Use the plug with an extension cord only if it can be fully inserted into the cord's socket.
- Never alter the plug in any way.

This fixture has been rated 40-watt maximum TYPE A standard bulb (not included). To avoid the risk of fire, do not exceed the recommended wattage.

WARNINGS

- All wires are connected; do not remove the lamp from its packaging by pulling on the power cord, as a bad connection may result.
- Do not connect electricity until the lamp is fully assembled.
- To reduce the risk of fire, electrical shock, or personal injury, always turn off and unplug lamp and allow it to cool prior to replacing light bulb.
- Do not touch bulb when fixture is turned on or look directly at lit bulb.
- Keep flammable materials away from light bulb.

FIGURE 02

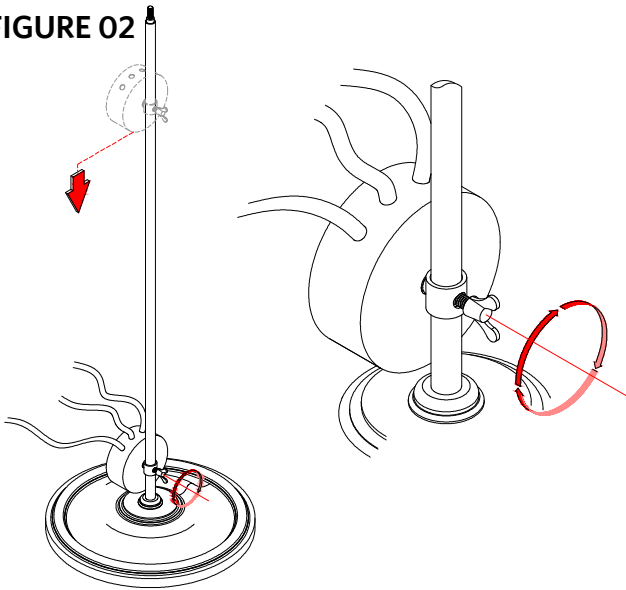
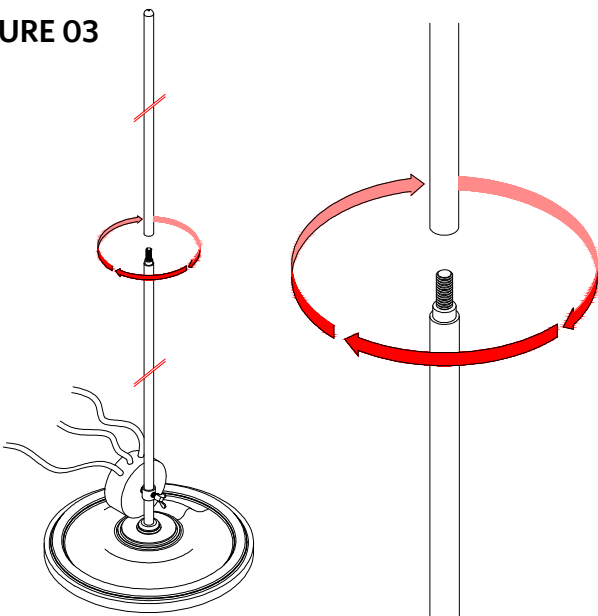

FIGURE 03



TOOLS AND HARDWARE

DESCRIPTION		QTY
	BASE	1 PC
	ROD - A ROD - B	1 SET
	RIGHT ANGLE CLAMP HOLDER	4 PCS
	SOCKET HOLDER	4 PCS
	JUNCTION BOX WITH SUCKET	1 SET

FIGURE 04



INSTRUCTIONS

1. Insert the threaded end of the Rod - A into the hole of the Base, once the Rod is set, then fasten the Rod with Hex Nut, Plain Washer and Lock Washer provided. Please see figure 01.
2. On the back of the Junction Box there is tube pipe with wing nut fasteners pre-installed. Set the Junction Box on the lower part of the Rod and tighten the wing nut to keep the Junction Box from moving. Please see figure 02
3. Install the Rod - B on end of threaded end of the Rod-A as in figure 03.
4. Set the Right Angle Clamp holder on the Rod on your desired height as shown in figure 04 - A, and secure these with the pre-installed thumb screw. Also install the Socket Holder on the other end of Right angle Clamp Holder as in figure 04-B.
5. Install the individual socket on the socket holder and secure these by tightening the thumb screw pre-installed on the socket holder.

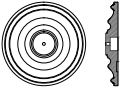
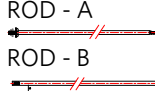
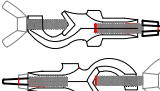
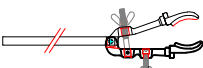
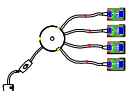
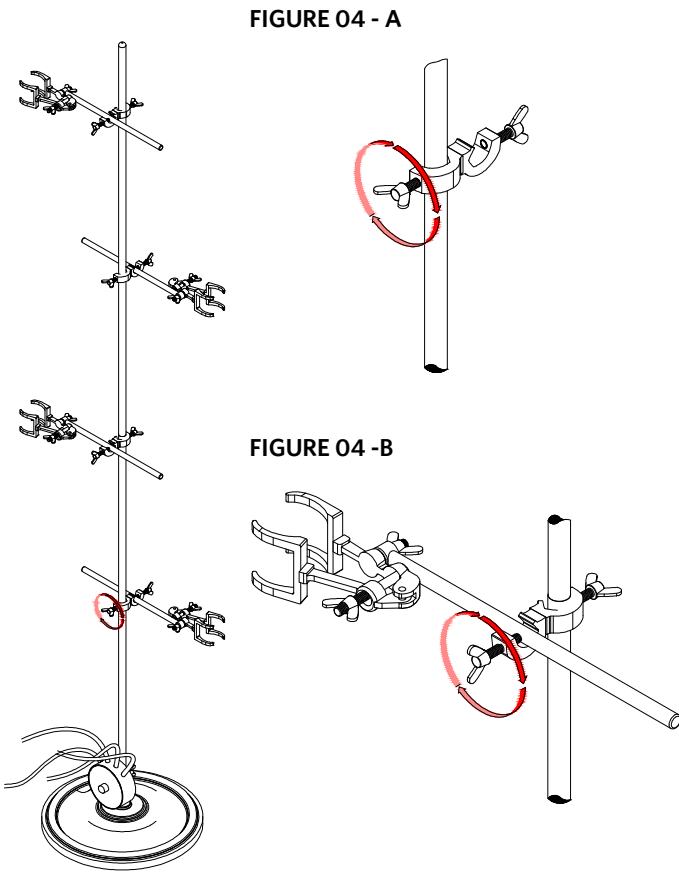
FIGURE 05

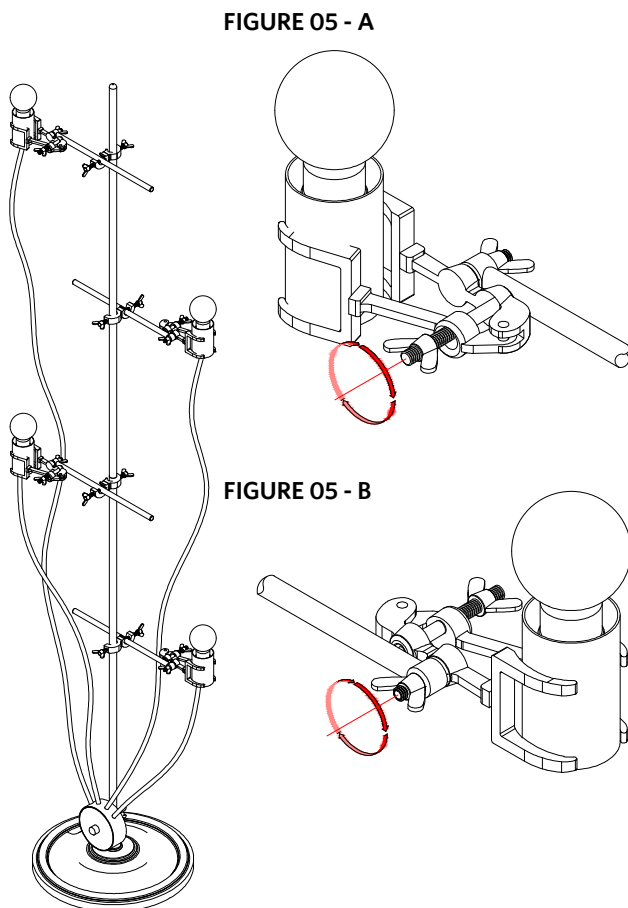

CARE INSTRUCTIONS:

Avoid the use of all polishers, cleaners, and abrasives, as they will damage the finish of your lamp. To remove dust or fingerprints, wipe gently with a soft, clean cloth.