

**Stage2**  
**Tie Rod Assemblies**  
**2001-2010**  
**GM 2500/3500HD Trucks**  
(158031000)

***Installation Guide***

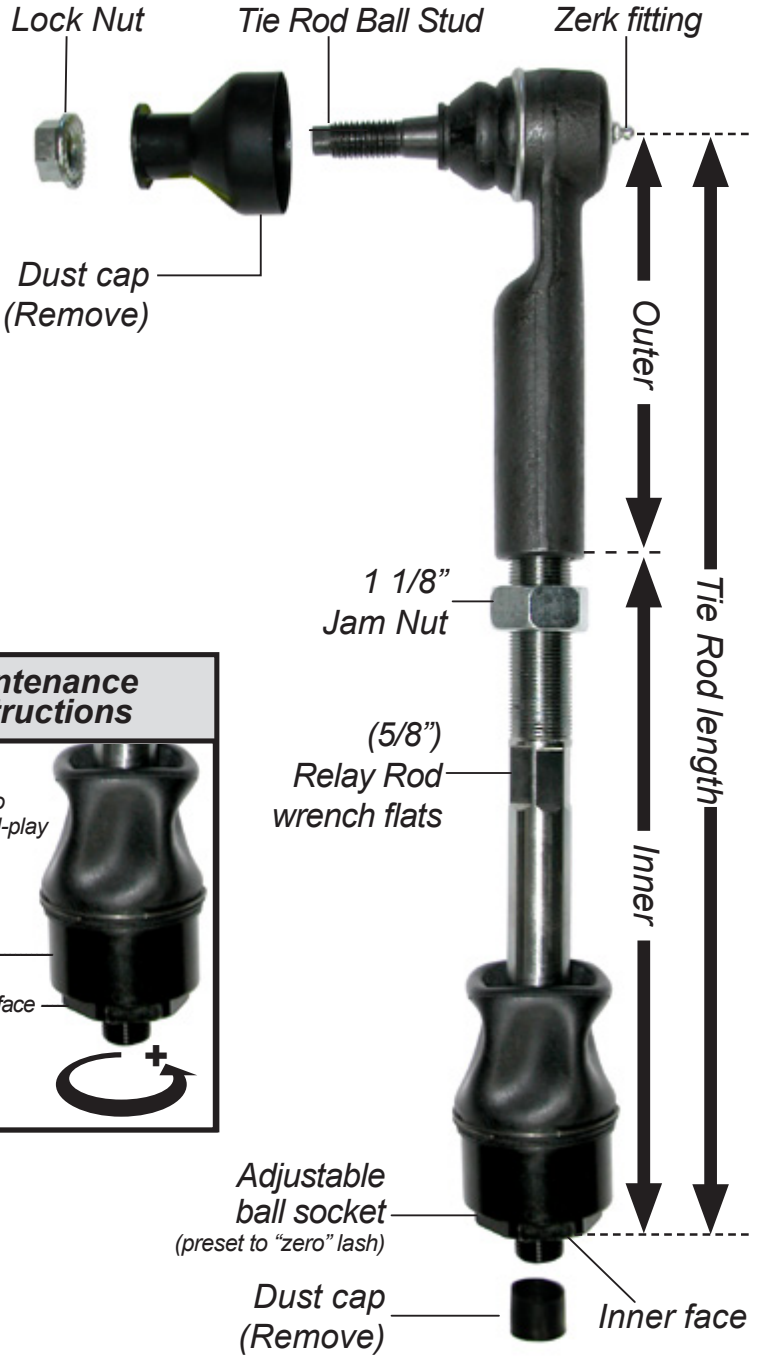

**Maintenance Instructions**

Adjustment to eliminate end-play

Use pliers to secure here

Tighten inner face

**Installation:** *Instructions for installation of new PPE Tie Rods to be performed on each side.*

*Remove front wheels and engine shield.*

- Step 1:** *Locate installed tie rods.*
- Step 2:** *Remove Lock Nut from outer Tie Rod Ball Stud. Use a tie rod fork tool to remove Tie Rod Ball Stud from tapered hole in Steering Knuckle.*
- Step 3:** *Unthread inner Tie Rod End from centerlink.*
- Step 4:** *Clean tapered hole and threaded end of center link.*
- Step 5:** *Measure length on removed tie rod from inner face to the center of the grease fitting.*
- Step 6:** *Using measurement from Step 5, adjust the length of the new PPE Tie Rod assembly to match the length of the old assembly.*
- Step 7:** *Tighten Jam Nut to lock length using a 1 1/8" wrench.*
- Step 8:** *Apply "red thread locker" and thread in the inner Tie Rod face to centerlink. Torque to 74 lb. ft.*
- Step 9:** *Insert tapered stud into tapered hole in spindle boss. Attach Lock Nut.*
- Step 10:** *Tighten lock nut using a 20 mm wrench. Torque to 48 lb. ft.*
- NOTE:** *A 9 mm wrench can be used to secure stud while tightening the Lock Nut.*
- Step 11:** *Grease outer Tie Rod end and center link with high-grade lubricant.*
- Step 12:** *Perform and confirm proper alignment and clearance. Longer sway bar end links may be required.*
- Step 13:** *To adjust toe, use 5/8" wrench on the inner flats if adjustment is necessary.*
- Step 14:** *Confirm/tighten set screws on Tie Rod inners.*
- Step 15:** *Steering wheel and toe adjustment will need to be adjusted to factory specs with a professional alignment.*

## **DISCLAIMER OF LIABILITY**

Performance products can increase horsepower above and beyond factory specifications. Additional horsepower creates more stress on the drive-train components, which could result in drive-train failure.

Note regarding emissions-related, non-E.O.-legal products: THESE PRODUCTS ARE LEGAL IN CALIFORNIA ONLY FOR RACING VEHICLES THAT MAY NEVER BE USED, OR REGISTERED OR LICENSED FOR HIGHWAY OR OFF-ROAD USE.

This agreement sets forth the terms and conditions for the use of PPE products. The installation of this product indicates that the Buyer has read and understands this agreement and accepts the terms and conditions. PPE (Pacific Performance Engineering) Inc., its distributors, employees, and dealers (the "Seller") shall not be responsible for the product's proper use and service. The buyer hereby waives all liability claims. The Buyer hereby acknowledges no reliance on the Seller's skill or judgment to select or furnish goods suitable for any particular purpose and that there are no liabilities which extend beyond the description on the face hereof, and the Buyer hereby waives all remedies or liabilities expressed or implied, arising by law or otherwise (including without any obligation of the Seller with respect to fitness, merchantability and consequential damages), or whether or not occasioned by the Seller's negligence. The Seller disclaims any warranty and expressly disclaims any liability for personal injury or damages. The Buyer acknowledges and agrees that the disclaimer of any liability for personal injury is a material term for this agreement and the Buyer agrees to indemnify the Seller and to hold the Seller harmless from any claim related to the item of equipment purchased. Under no circumstances will the Seller be liable for any damages or expenses by reason of use or sale of any such equipment. The Seller assumes no liability regarding the improper installation or misapplication of its products. It is the installer's responsibility to check for proper installation and if in doubt, contact the manufacturer. The Buyer is solely responsible for all warranty issues from the manufacturer.

## **LIMITATION OF WARRANTY**

The Seller gives Limited Warranty as to description, quality, merchantability, and fitness for a particular purpose, productiveness, or any other matter of Seller's product sold herewith. The Seller shall not be responsible for the products proper use and service and the Buyer hereby waives all rights other than those expressly written herein. This warranty shall not be extended, altered or varied except by a written instrument signed by Seller and Buyer.

Limited lifetime warranty on all PPE cast aluminum products, and PPE Transmission Coolers. Three (3) year limited warranty on PPE Manifolds and Up-Pipes Kits, and OEM-Length Up-Pipes. One (1) year limited warranty on all other PPE products from the date of sale to original buyer and limited solely to the parts contained within the products kit. All products that are in question of Warranty must be returned prepaid to the Seller and must be accompanied by a dated proof of purchase receipt. All Warranty claims are subject to approval by Seller. Under no circumstances will the Seller be liable for any labor charged or travel time incurred in diagnosis for defects, removal, or re-installation - of this product or any other contingent expenses. Under no circumstances will the Seller be liable for any damage or expenses incurred by reason of the use or sale of any such equipment. In the event that the buyer does not agree with this agreement: the buyer may promptly return this product, in a new and unused condition in its original packaging, with a dated proof of purchase to the place of purchase within ten (10) days from date of purchase for a full refund. The installation of this product indicates that the buyer has read and understands this agreement and accepts its terms and conditions.



*PPEpower.com*