

Heavy-Duty Cast Aluminum Rear Differential Cover

GM 1972-2013 K1500 10-8.5"

(138051300, 138051310, 138051320)

Installation Guide

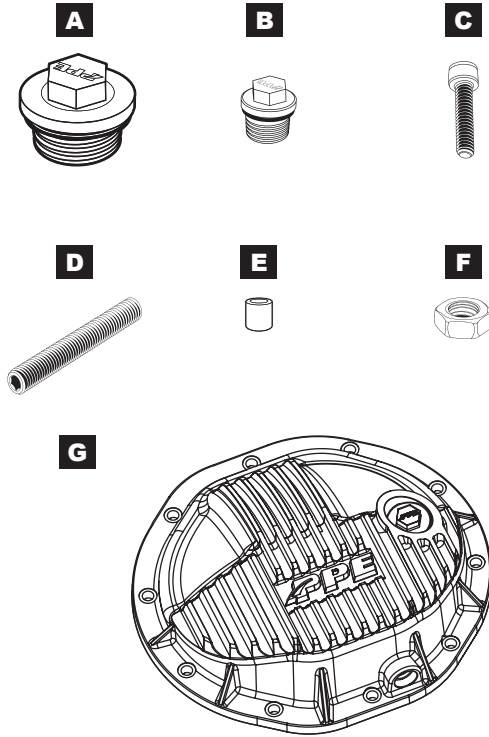

CONTENTS:

- A** (1) One-inch Neodymium Magnet equipped Fill Plug (installed)
- B** (1) 9/16" ORB Neodymium Magnetic Drain Plug (installed)
- C** (8) M8 - 1.25 x 30mm Socket Head Cap Screw
- D** (2) M8 - 1.25 x 55mm Plated Steel Stud
- E** (2) Stainless Steel Spacer
- F** (2) M8-1.25 Steel Nut
- G** (1) PPE Cast Aluminum Rear Differential Cover

INSTALLATION:

Step 1. Vehicle off, secure, and cool.

Step 2. Remove stock hardware and cover. Drain and recycle oil. (Fig. 1)

If your vehicle is equipped with a brake line bracket secured to the OEM differential cover, note the alignment and where the bracket is attached. It will be reinstalled.

Step 3. Check if the factory has used a gasket. If the gasket is in good condition, carefully remove it from the old cover and clean it thoroughly. Transfer the cleaned gasket to the new cover. However, if the gasket is damaged or worn, it is recommended to replace it with a new one. In the absence of a gasket, gently scrape off any residual silicone from the mating surface of the pan housing. (Fig. 2)

Step 4. Apply a continuous bead of RTV sealant onto the PPE diff cover flange and around bolt holes. (Fig. 3)

Step 5. Install PPE diff cover on the housing by placing one M8 screw (C) on either side of the flange and finger tight for now. (Fig. 4)



Step 6. If the vehicle is equipped with a brake line bracket, place an M8 stud (D) in place of screw (C) (Fig. 5).

Install remaining screws and torque to 20-25 lb-ft in crossing pattern as depicted in (Fig. 6).

Note: Allow for RTV manufacturer's recommended time for silicone setup.

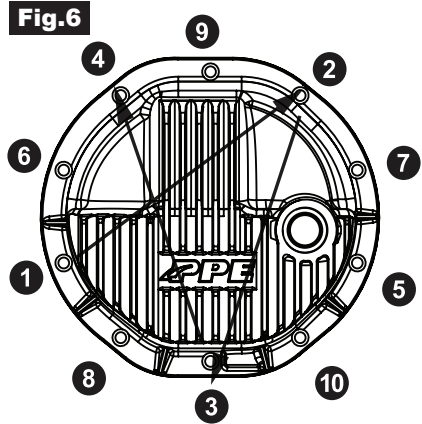

Step 7. Slide spacers (E) over the studs followed by the brake line bracket and secure with M8 nut (F).

Step 8. Torque Drain Plug (B) to 13-15 lb-ft.



Step 9. Remove fill plug (A) and fill to manufacturer recommended level with manufacturer recommended differential fluid.

Torque fill plug (A) to 20-23 lb-ft.

Check for leaks.

This completes the installation.



THIS PAGE INTENTIONALLY BLANK

DISCLAIMER OF LIABILITY

Performance products can increase horsepower above and beyond factory specifications. Additional horsepower creates more stress on the drive-train components, which could result in drive-train failure.

Note regarding emissions-related, non-E.O.-legal products: THESE PRODUCTS ARE LEGAL IN CALIFORNIA ONLY FOR RACING VEHICLES THAT MAY NEVER BE USED, OR REGISTERED OR LICENSED FOR HIGHWAY OR OFF-ROAD USE.

This agreement sets forth the terms and conditions for the use of PPE products. The installation of this product indicates that the Buyer has read and understands this agreement and accepts the terms and conditions. PPE (Pacific Performance Engineering) Inc., its distributors, employees, and dealers (the "Seller") shall not be responsible for the product's proper use and service. The buyer hereby waives all liability claims. The Buyer hereby acknowledges no reliance on the Seller's skill or judgment to select or furnish goods suitable for any particular purpose and that there are no liabilities which extend beyond the description on the face hereof, and the Buyer hereby waives all remedies or liabilities expressed or implied, arising by law or otherwise (including without any obligation of the Seller with respect to fitness, merchantability and consequential damages), or whether or not occasioned by the Seller's negligence. The Seller disclaims any warranty and expressly disclaims any liability for personal injury or damages. The Buyer acknowledges and agrees that the disclaimer of any liability for personal injury is a material term for this agreement and the Buyer agrees to indemnify the Seller and to hold the Seller harmless from any claim related to the item of equipment purchased. Under no circumstances will the Seller be liable for any damages or expenses by reason of use or sale of any such equipment. The Seller assumes no liability regarding the improper installation or misapplication of its products. It is the installer's responsibility to check for proper installation and if in doubt, contact the manufacturer. The Buyer is solely responsible for all warranty issues from the manufacturer.

LIMITATION OF WARRANTY

The Seller gives Limited Warranty as to description, quality, merchantability, and fitness for a particular purpose, productiveness, or any other matter of Seller's product sold herewith. The Seller shall not be responsible for the products proper use and service and the Buyer hereby waives all rights other than those expressly written herein. This warranty shall not be extended, altered or varied except by a written instrument signed by Seller and Buyer.

Limited lifetime warranty on all PPE cast aluminum products, and PPE Transmission Coolers. Three (3) year limited warranty on PPE Manifolds and Up-Pipes Kits, and OEM-Length Up-Pipes. One (1) year limited warranty on all other PPE products from the date of sale to original buyer and limited solely to the parts contained within the products kit. All products that are in question of Warranty must be returned prepaid to the Seller and must be accompanied by a dated proof of purchase receipt. All Warranty claims are subject to approval by Seller. Under no circumstances will the Seller be liable for any labor charged or travel time incurred in diagnosis for defects, removal, or re-installation - of this product or any other contingent expenses. Under no circumstances will the Seller be liable for any damage or expenses incurred by reason of the use or sale of any such equipment. In the event that the buyer does not agree with this agreement: the buyer may promptly return this product, in a new and unused condition in its original packaging, with a dated proof of purchase to the place of purchase within ten (10) days from date of purchase for a full refund. The installation of this product indicates that the buyer has read and understands this agreement and accepts its terms and conditions.



PPEpower.com