

# **Chevy LS Gen III/IV Small Block Main Stud Kit**

(118130100)

## ***Installation Guide***

**ATTENTION:** We recommend the installation of this part be done by a trained professional GM technician. PPE will not accept liability for damage resulting from incorrect assembly.

These instructions are not intended as a service or overhaul manual. These instructions are intended to facilitate the modification of non-factory parts installation by a trained professional.

**NOTE:** Tolerances will change when changing from factory to high-strength fasteners. It will be necessary to check main bearing bores for proper size and out-of-round condition after installation of the studs. Hone the cylinder block if necessary. Main bores should always be align-honed using the same fasteners and lubricant which will be installed, at the recommended preload, during the final engine assembly.

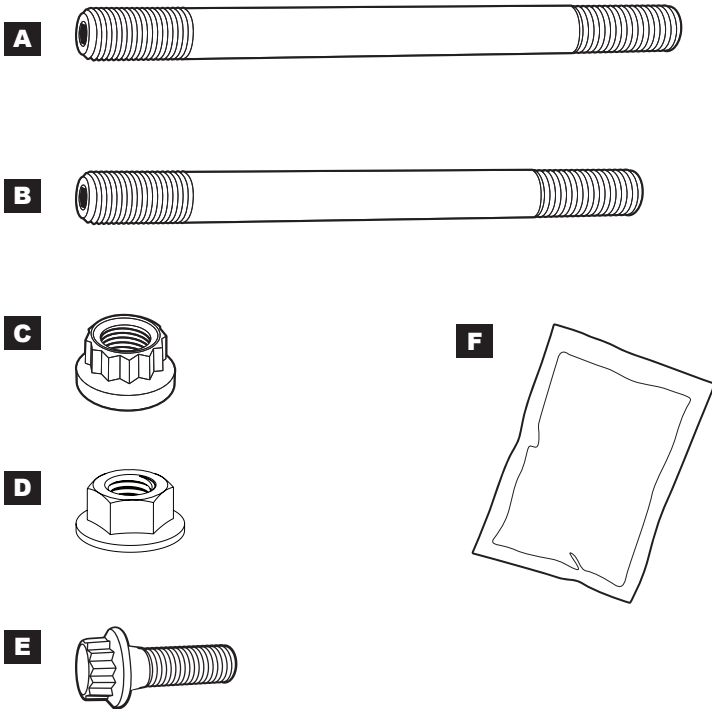

**CONTENTS**

- A: 4.78" M10 Studs - (10)
- B: 4.57" M10 Studs - (10)
- C: 12-pt M10 Flange Nuts - (20)
- D: M10 Hex Flange Nuts - (10)
- E: 12-pt M8 Bolts - (10)
- F: Fastener Assembly Lubrication 1-oz. - (1)

## Chevy LS Gen III/IV Small Block Main Stud Kit

Inspect for damage or defects and clean all hardware prior to installation. Verify product part number matches your application.

### NOTE:

Loctite may be used for permanent mounting. Torque sequences must be complete prior to Loctite hardening.

Clean all threads in the engine block. Use a Bottoming Thread Chaser if necessary, to ensure thread engagement, and more accurate torque readings.

Install Inner (A) and outer Studs (B) into the block. Hand-tighten without tools (equivalent of 20-30 in. lbs.). Verify consistent Stud (A) height using a straight-edge ruler. Install the main caps and check for binding or misalignment.

Lubricate Stud (A & B) threads, M10 12-pt Flange Nuts (C) with the Fastener Assembly Lubricant (F). Then install the M10 12-pt Flange Nuts onto the studs and hand tighten them.

Tighten nuts in three equal steps using the torque sequence to a total spec:

(Red) 1-10 Inner studs – 4.78" long 60 lb-ft

(Blue) 11-20 Outer studs – 4.57" long 50 lb-ft

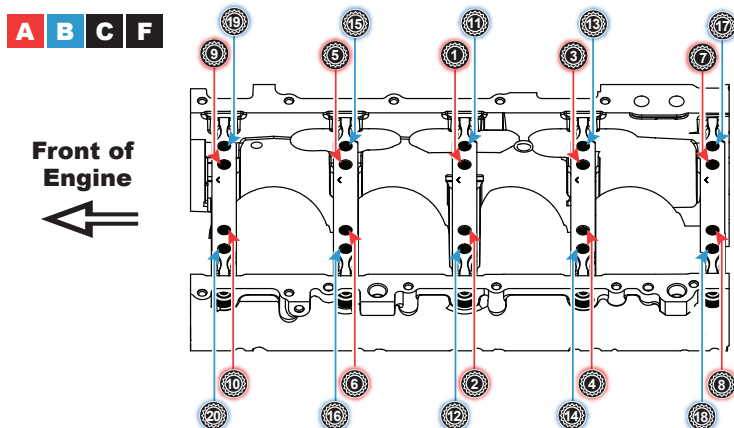

Lubricate M8 12-pt Bolt (E) threads with Lubricant (F).

(Green) 21-30 Tighten M8 Cross Bolts to torque spec = 20 lb-ft.

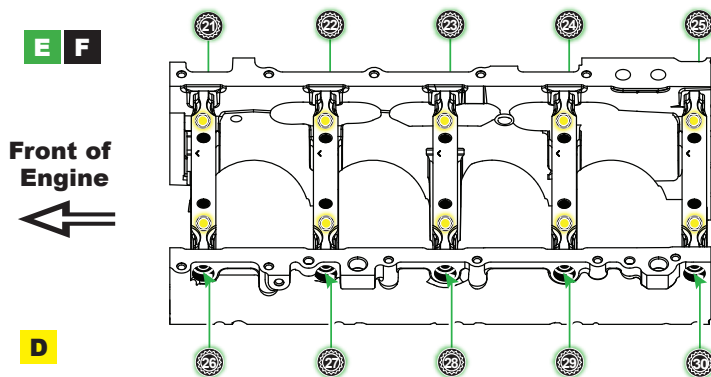

Tighten Windage tray nuts to torque spec – 28 lb-ft

## **DISCLAIMER OF LIABILITY**

Performance products can increase horsepower above and beyond factory specifications. Additional horsepower creates more stress on the drive-train components, which could result in drive-train failure.

Note regarding emissions-related, non-E.O.-legal products: THESE PRODUCTS ARE LEGAL IN CALIFORNIA ONLY FOR RACING VEHICLES THAT MAY NEVER BE USED, OR REGISTERED OR LICENSED FOR HIGHWAY OR OFF-ROAD USE.

This agreement sets forth the terms and conditions for the use of PPE products. The installation of this product indicates that the Buyer has read and understands this agreement and accepts the terms and conditions. PPE (Pacific Performance Engineering) Inc., its distributors, employees, and dealers (the "Seller") shall not be responsible for the product's proper use and service. The buyer hereby waives all liability claims. The Buyer hereby acknowledges no reliance on the Seller's skill or judgment to select or furnish goods suitable for any particular purpose and that there are no liabilities which extend beyond the description on the face hereof, and the Buyer hereby waives all remedies or liabilities expressed or implied, arising by law or otherwise (including without any obligation of the Seller with respect to fitness, merchantability and consequential damages), or whether or not occasioned by the Seller's negligence. The Seller disclaims any warranty and expressly disclaims any liability for personal injury or damages. The Buyer acknowledges and agrees that the disclaimer of any liability for personal injury is a material term for this agreement and the Buyer agrees to indemnify the Seller and to hold the Seller harmless from any claim related to the item of equipment purchased. Under no circumstances will the Seller be liable for any damages or expenses by reason of use or sale of any such equipment. The Seller assumes no liability regarding the improper installation or misapplication of its products. It is the installer's responsibility to check for proper installation and if in doubt, contact the manufacturer. The Buyer is solely responsible for all warranty issues from the manufacturer.

## **LIMITATION OF WARRANTY**

The Seller gives Limited Warranty as to description, quality, merchantability, and fitness for a particular purpose, productiveness, or any other matter of Seller's product sold herewith. The Seller shall not be responsible for the products proper use and service and the Buyer hereby waives all rights other than those expressly written herein. This warranty shall not be extended, altered or varied except by a written instrument signed by Seller and Buyer.

Limited lifetime warranty on all PPE cast aluminum products, and PPE Transmission Coolers. Three (3) year limited warranty on PPE Manifolds and Up-Pipes Kits, and OEM-Length Up-Pipes. One (1) year limited warranty on all other PPE products from the date of sale to original buyer and limited solely to the parts contained within the products kit. All products that are in question of Warranty must be returned prepaid to the Seller and must be accompanied by a dated proof of purchase receipt. All Warranty claims are subject to approval by Seller. Under no circumstances will the Seller be liable for any labor charged or travel time incurred in diagnosis for defects, removal, or re-installation - of this product or any other contingent expenses. Under no circumstances will the Seller be liable for any damage or expenses incurred by reason of the use or sale of any such equipment. In the event that the buyer does not agree with this agreement: the buyer may promptly return this product, in a new and unused condition in its original packaging, with a dated proof of purchase to the place of purchase within ten (10) days from date of purchase for a full refund. The installation of this product indicates that the buyer has read and understands this agreement and accepts its terms and conditions.



*PPEpower.com*