

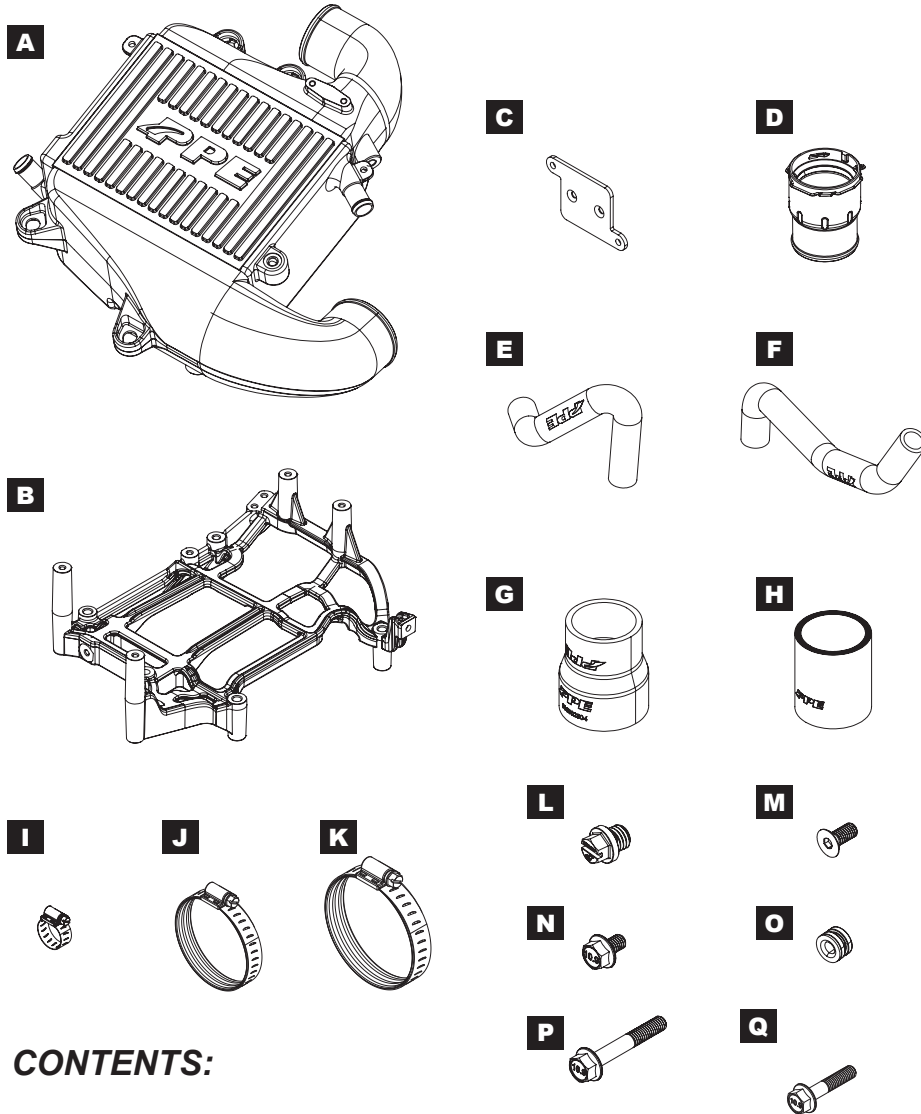
Intercooler Kit - Water to Air

*2020-2023 Chevrolet/GMC
Silverado, Sierra
3.0L Duramax LM2/LZO*

*2021-2023 Chevrolet/GMC/Cadillac
Suburban, Tahoe, Yukon, Escalade
3.0L Duramax LM2/LZO*

(115030000), (115030010), (115030012), (115030022)

Installation Guide



CONTENTS:

- A** (1) Intercooler
- B** (1) Base Bracket
- C** (1) NOx Control Module Bracket
- D** (1) Turbo Adapter/Resonator delete
- E** (1) Silicone Coolant Hose (IN)
- F** (1) Silicone Coolant Hose (OUT)
- G** (1) Silicone Reducer (3.0" to 2.5" x 4" length)
- H** (1) Silicone Straight Coupler (2.5" x 3.5" length)
- I** (4) Coolant Hose Worm Clamp
- J** (3) W-Style Constant Tension Worm Drive Clamp (52-76 mm)
- K** (1) W-Style Constant Tension Worm Drive Clamp (65-89 mm)
- L** (1) Air Bleeder Screw, Black
- M** (2) M6 Countersink Screw
- N** (2) M6-1.0X12mm Flange Bolt
- O** (4) Rubber Grommet/Steel Bushing (installed)
- P** (1) M6-1.0X55 Flange Bolt
- Q** (1) M6-1.0X30 Turbo Heat Shield Bolt

INSTALLATION:

1. Vehicle off and cool. Disconnect negative battery terminal. Isolate for safety by placing a piece of rubber or cardboard under the disconnected terminal and the battery. **(Fig.1)**

2. Remove Oil Cap. Remove Engine Cover.



Fig.1

3. Disconnect NOx Control Module. Disconnect the loom-wrapped harness, move out of the way and secure. **(Fig.2)**

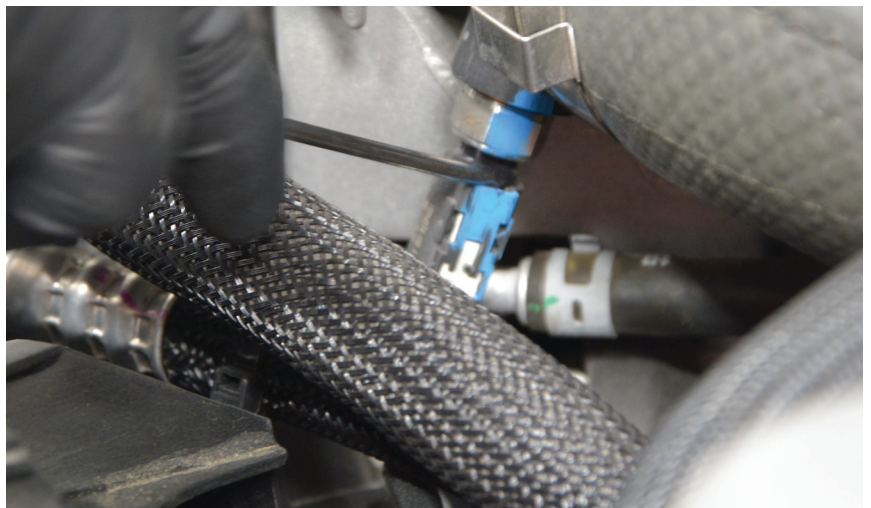
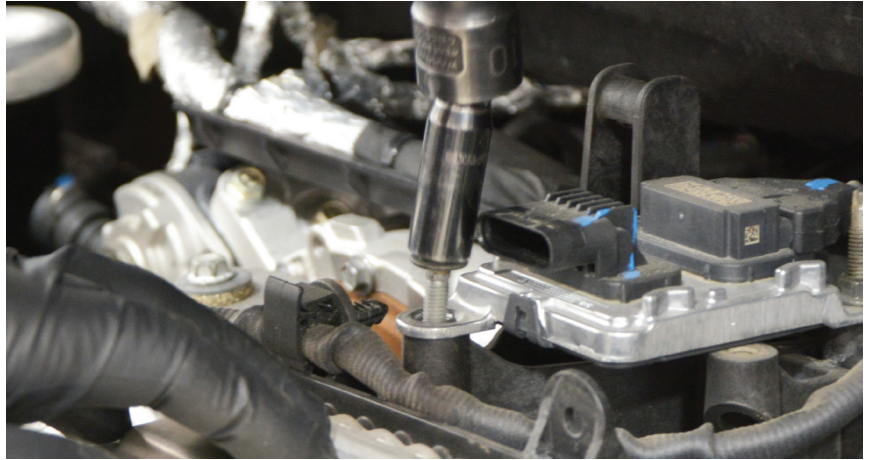


Fig.2

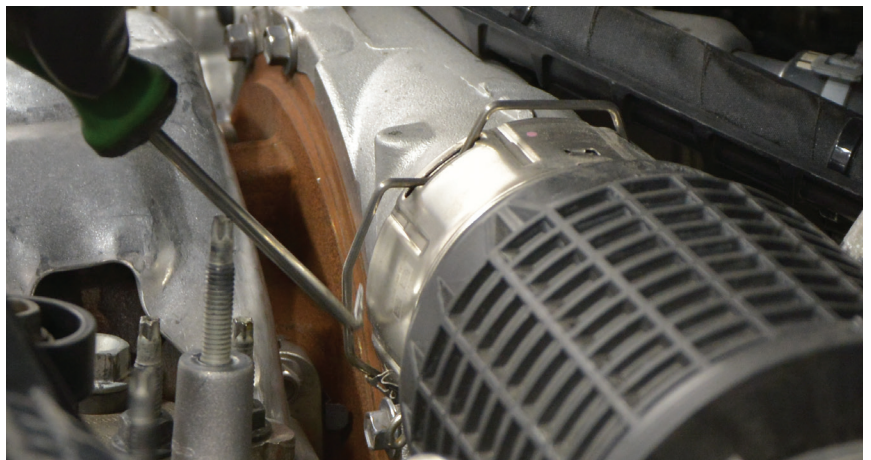
4. *Unbolt and move the NOx Control Module out of the way. (Fig.3) Save factory nuts for use later.*

**Fig.3**

5. *Unbolt and remove NOx Control Module bracket. (Fig.4)*

**Fig.4**

6. *Unclip and remove Turbo Resonator. (Fig.5)*

**Fig.5**

7. Disconnect and remove Intercooler Outlet Hose. **(Fig.6)**



Fig.6

8. Disconnect Inlet Coolant Hose. **(Fig.7)**



Fig.7

9. Disconnect Outlet Coolant Hose. **(Fig.8)**

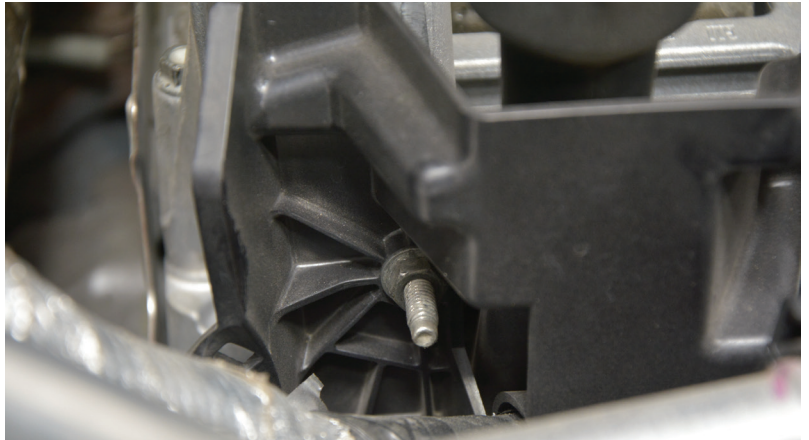


Fig.8

10. *Unbolt and remove stock Intercooler. Retain 4 factory screws. (Fig.9)*

**Fig.9**

11. *Remove factory nut and stud, and the front bracket. Save for reinstall. (Fig.10)*

**Fig.10**

12. *Remove fasteners from Turbo Shield. Move Shield to the side. (Fig.11)*

**Fig.11**

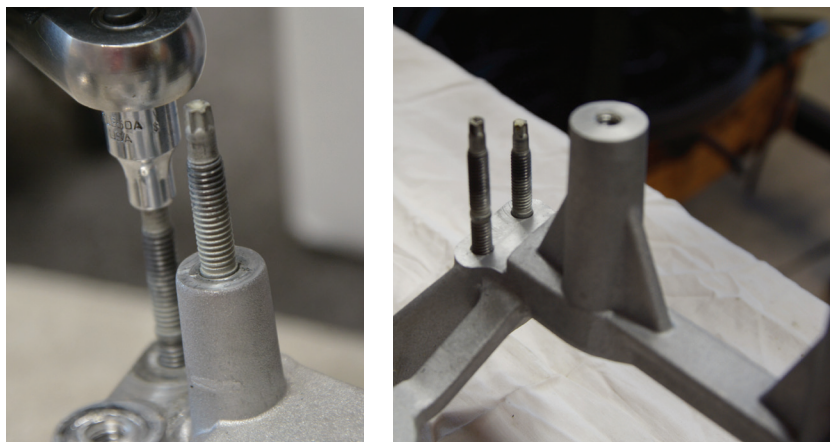
13. *Unbolt and remove Turbo to Base Bracket securing plate. Retain stock bolt and nuts for reuse. (Fig.12)*

**Fig.12**

14. *Unbolt and remove stock Base Bracket. (Fig.13) Save bolts for reinstall.*

**Fig.13**

15. *Remove the 2 stock left rear studs on the stock bracket and install in the locations shown on the PPE Base Bracket (B). (Fig.14)*

**Fig.14**

16. Carefully remove sensors and save for reuse. (Note the two factory front and rear temperature sensors are different and need to be reinstalled in their correct locations) **(Fig.15)**



Fig.15

17. Install front and rear temperature sensors in their correct locations on the PPE Intercooler. **(Fig.16)**



Fig.16

18. Install PPE Base Bracket. Install supplied PPE M6 Flange Bolt (P) in location shown. **(Fig.17)**

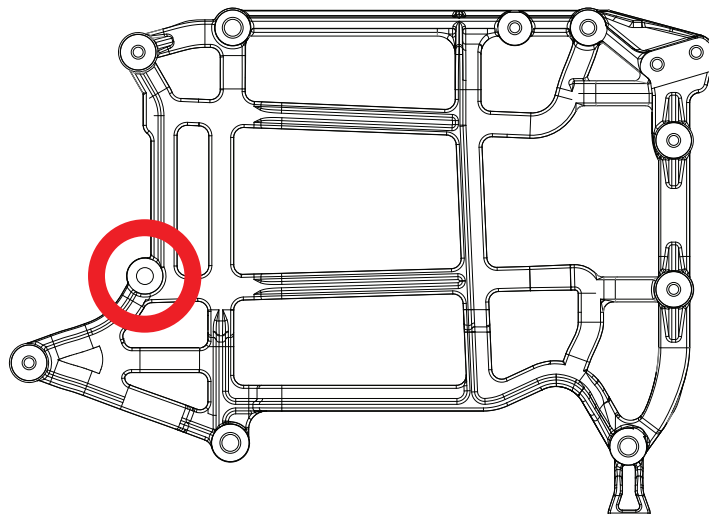


Fig.17

Install remaining factory bolts from Step 13. Tighten to secure. **(Fig.18)**



Fig.18

19. Reinstall stud and front plate that was removed in Step 10. **(Fig.19)**

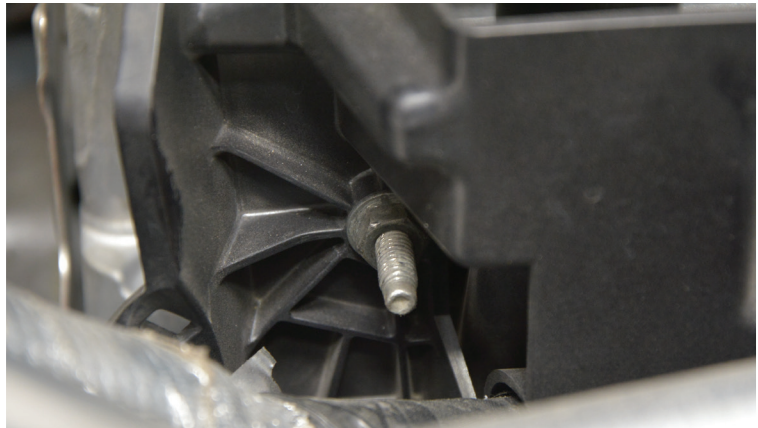


Fig.19

20. Reinstall Turbo to Base Bracket securing plate over reinstalled studs from Step 14. Reinstall nuts on studs then bolt to secure turbo. Tighten to secure. **(Fig.20)**

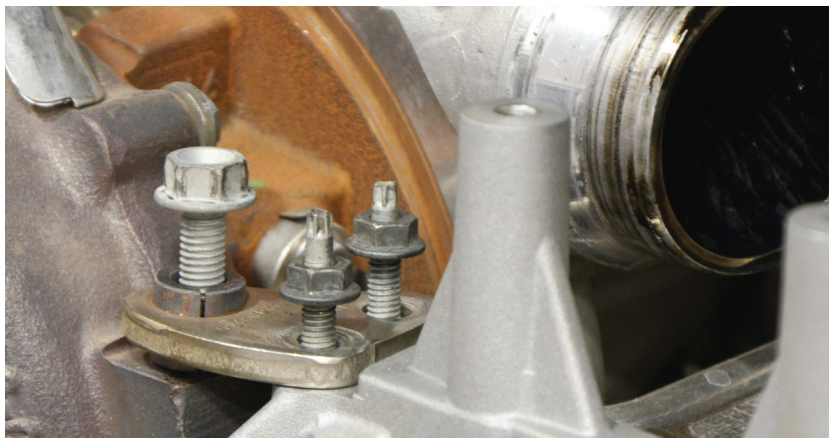
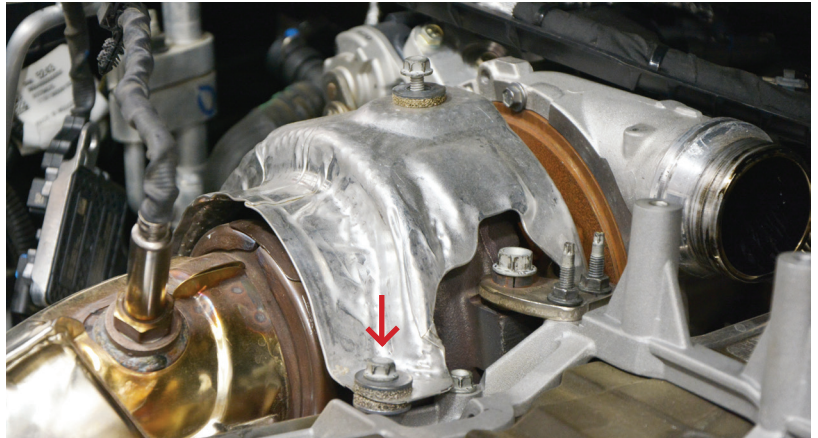


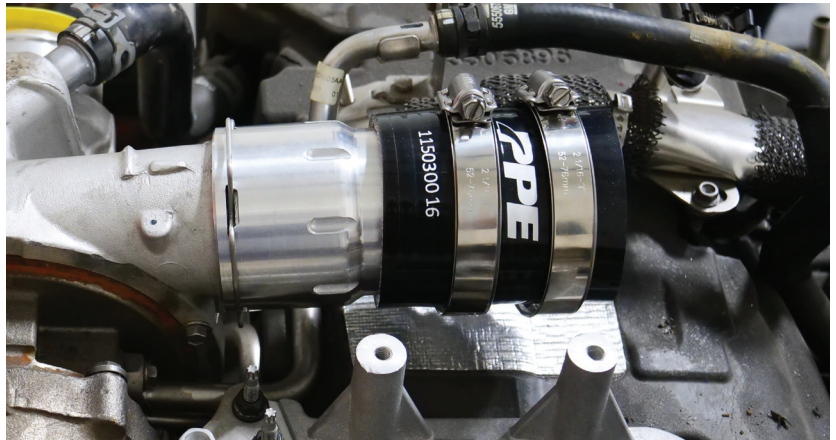
Fig.20

21. Reinstall Turbo Heat Shield and reinstall fasteners. Use provided M6x30mm Bolt (Q) Tighten to secure. **(Fig.21)**

**Fig.21**

22. Lubricate O-Ring on PPE Turbo Adapter (D) with silicone brake lube.

23. Install and secure PPE Turbo Adapter (D) to turbo. Install PPE Straight Coupler (H) to PPE Turbo Adapter. Slide 2 W-Style Constant Tension Clamps (J) on to the coupler. **(Fig.22)**

**Fig.22**

24. Fit Straight Coupler assembly over PPE Intercooler inlet by tilting the cooler so the outlet side is higher. **(Fig.23)** Align Intercooler inlet with the Straight Coupler (H) then push inlet into the Coupler.

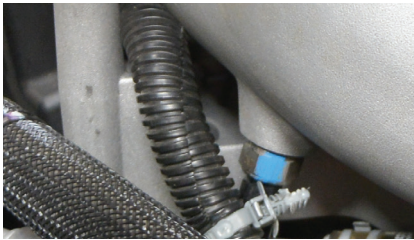
Loosely tighten clamp, allowing for final adjustment.

**Fig.23**

25. Slide 2 PPE W-Style Constant Tension Clamps (J,K) on the throttle body. Install PPE Reducer (G) on Intercooler outlet.

Fit installed Reducer end over throttle body. Loosely tighten T-Bolt Clamps to allow for minor adjustments. **(Fig.24)**

26. Route loom-wrapped harness under the Intercooler behind the Base Bracket.



27. Lower Intercooler on to Base Bracket and install 4 saved factory bolts from Step 9. Tighten bolts to secure Intercooler. **(Fig.25)** Tighten T-Bolt Clamps (J,K) on Intercooler inlet and outlet to secure.



Fig.24



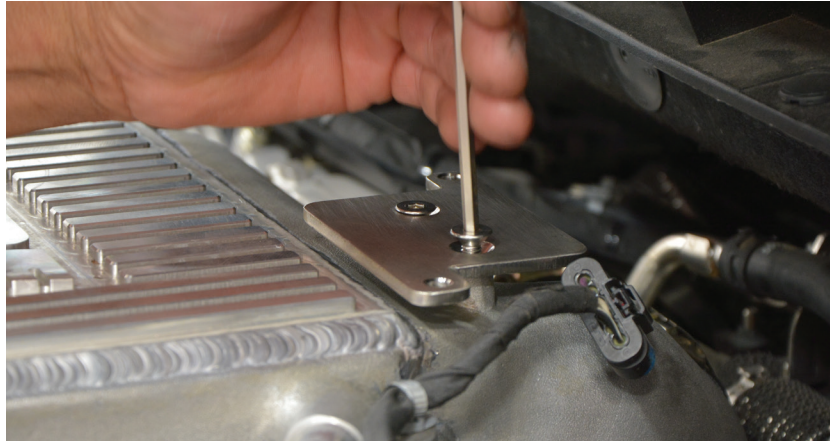
Fig.25

28. Reinstall sensor connections. Reinstall harness clips to secure. **(Fig.26)**

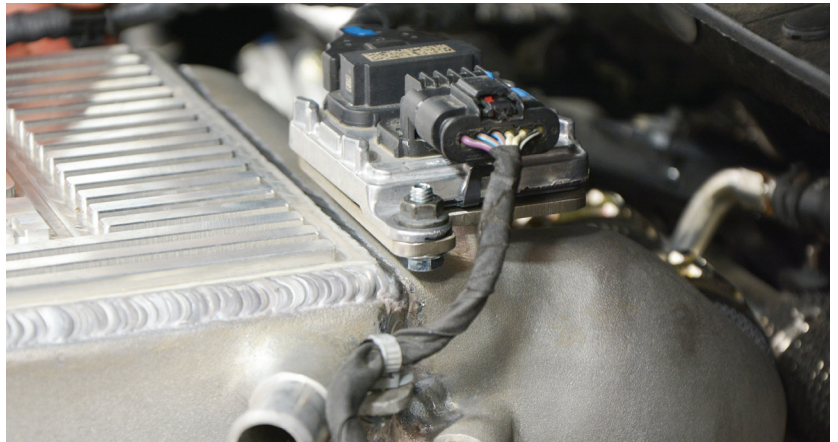


Fig.26

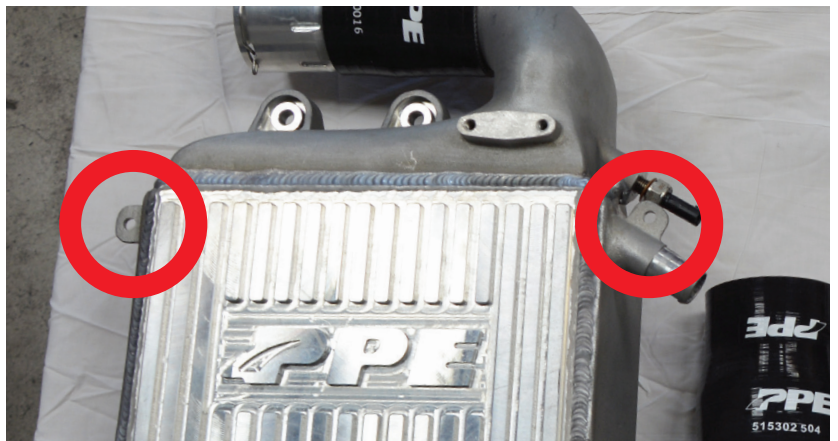
29. Install PPE Sensor Bracket (C) in the location shown. Thread and tighten M6 Screws (M) to secure Sensor Bracket. (Fig.27)

**Fig.27**

30. Reinstall factory NOx Control Module on top of the PPE NOx Control Module Bracket. Thread the saved factory nuts from Step 3 on to M6 Flange Bolts (N) Tighten to secure. (Fig.28)

**Fig.28**

31. Insert harness clips into the cast-in tabs on each side of the Intercooler. (Fig.29)

**Fig.29**

32. Install 2 Worm Clamps (I) on each end of the PPE Coolant Hose (F) Fit PPE Coolant Hose onto PPE Intercooler outlet and factory Reservoir. Tighten Clamps to secure. **(Fig.30)**

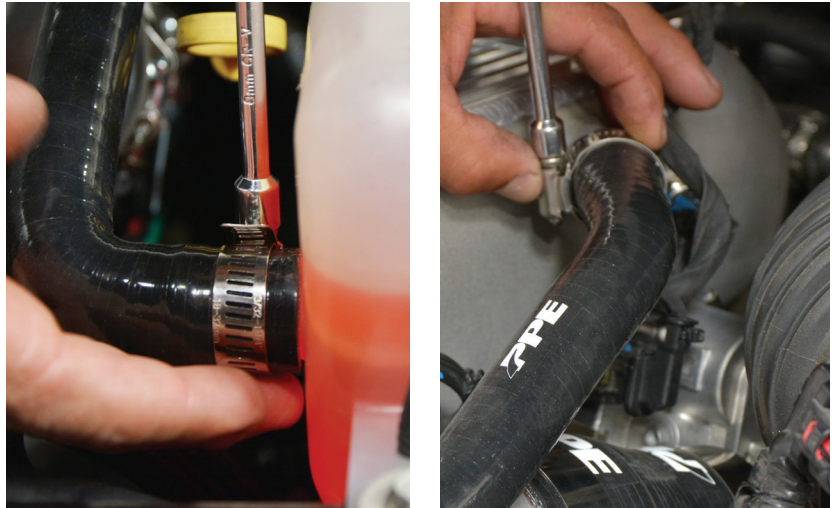


Fig.30

33. Install two Worm Clamps (I) onto Silicone Coolant Hose (E) Install assembly onto Intercooler. Tighten to secure Worm Clamps. **(Fig.31)**
34. Check and final-tighten all Clamps and fasteners. Check clearances. Replace oil cap.



Fig.31

Coolant bleeding procedure

Reconnect negative battery terminal.

Have the PPE Bleeder Screw (L) ready.

Remove coolant reservoir cap. Fill coolant reservoir to Full. Unbolt coolant reservoir. **(Fig.32)** Raise the coolant reservoir above the level of the PPE



Fig.32

Intercooler. The coolant will flow into the Intercooler.

Keep the Reservoir elevated above the Intercooler. Carefully fill Reservoir until fluid starts to flow out of the port. **(Fig.33)**

Install and tighten the PPE Bleeder Screw (L).

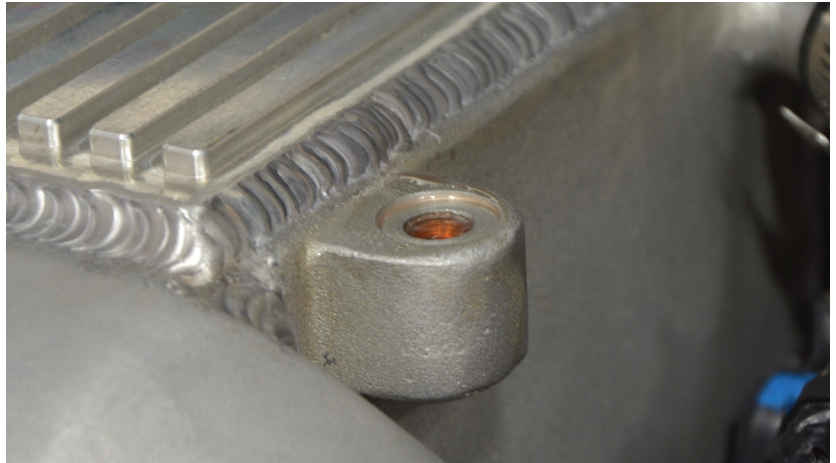


Fig.33

Fill to the indicator line on the Reservoir. Replace cap and reinstall Reservoir. **(Fig.34)**

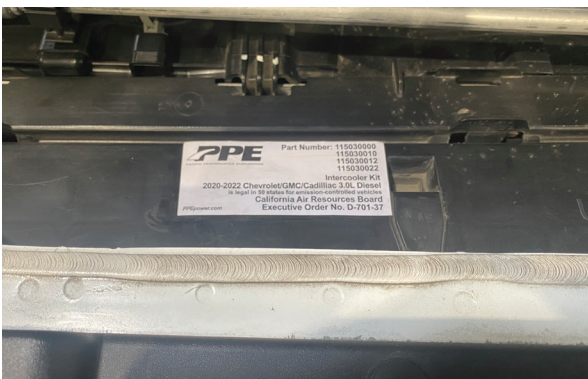
Drive vehicle and bring up to operating temperature.

Check and refill the coolant reservoir to the fill line if necessary.



Fig.34

Place the supplied CARB E.O. label on a clean, visible location under the hood. PPE recommends using the top side of the fan shroud.



DISCLAIMER OF LIABILITY

Performance products can increase horsepower above and beyond factory specifications. Additional horsepower creates more stress on the drive-train components, which could result in drive-train failure.

Note regarding emissions-related, non-E.O.-legal products: THESE PRODUCTS ARE LEGAL IN CALIFORNIA ONLY FOR RACING VEHICLES THAT MAY NEVER BE USED, OR REGISTERED OR LICENSED FOR HIGHWAY OR OFF-ROAD USE.

This agreement sets forth the terms and conditions for the use of PPE products. The installation of this product indicates that the Buyer has read and understands this agreement and accepts the terms and conditions. PPE (Pacific Performance Engineering) Inc., its distributors, employees, and dealers (the "Seller") shall not be responsible for the product's proper use and service. The buyer hereby waives all liability claims. The Buyer hereby acknowledges no reliance on the Seller's skill or judgment to select or furnish goods suitable for any particular purpose and that there are no liabilities which extend beyond the description on the face hereof, and the Buyer hereby waives all remedies or liabilities expressed or implied, arising by law or otherwise (including without any obligation of the Seller with respect to fitness, merchantability and consequential damages), or whether or not occasioned by the Seller's negligence. The Seller disclaims any warranty and expressly disclaims any liability for personal injury or damages. The Buyer acknowledges and agrees that the disclaimer of any liability for personal injury is a material term for this agreement and the Buyer agrees to indemnify the Seller and to hold the Seller harmless from any claim related to the item of equipment purchased. Under no circumstances will the Seller be liable for any damages or expenses by reason of use or sale of any such equipment. The Seller assumes no liability regarding the improper installation or misapplication of its products. It is the installer's responsibility to check for proper installation and if in doubt, contact the manufacturer. The Buyer is solely responsible for all warranty issues from the manufacturer.

LIMITATION OF WARRANTY

The Seller gives Limited Warranty as to description, quality, merchantability, and fitness for a particular purpose, productiveness, or any other matter of Seller's product sold herewith. The Seller shall not be responsible for the products proper use and service and the Buyer hereby waives all rights other than those expressly written herein. This warranty shall not be extended, altered or varied except by a written instrument signed by Seller and Buyer.

Limited lifetime warranty on all PPE cast aluminum products, and PPE Transmission Coolers. Three (3) year limited warranty on PPE Manifolds and Up-Pipes Kits, and OEM-Length Up-Pipes. One (1) year limited warranty on all other PPE products from the date of sale to original buyer and limited solely to the parts contained within the products kit. All products that are in question of Warranty must be returned prepaid to the Seller and must be accompanied by a dated proof of purchase receipt. All Warranty claims are subject to approval by Seller. Under no circumstances will the Seller be liable for any labor charged or travel time incurred in diagnosis for defects, removal, or re-installation - of this product or any other contingent expenses. Under no circumstances will the Seller be liable for any damage or expenses incurred by reason of the use or sale of any such equipment. In the event that the buyer does not agree with this agreement: the buyer may promptly return this product, in a new and unused condition in its original packaging, with a dated proof of purchase to the place of purchase within ten (10) days from date of purchase for a full refund. The installation of this product indicates that the buyer has read and understands this agreement and accepts its terms and conditions.



PPEpower.com



PPEpower.com