

M4 Button Head Cap Machine Screws (BHCS)

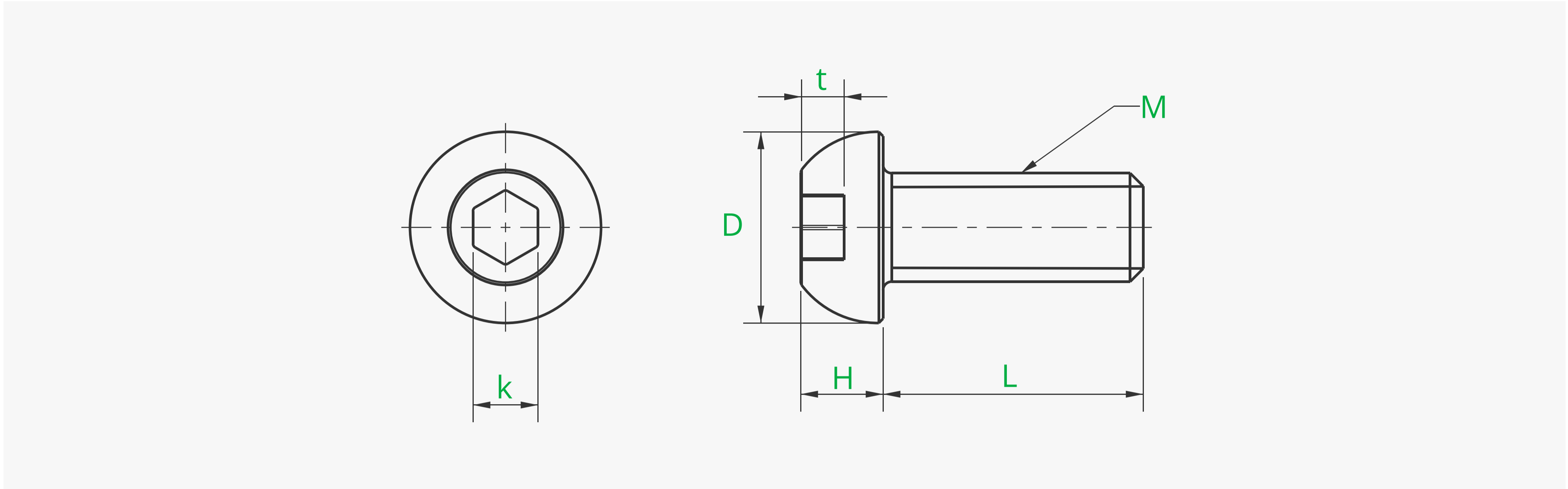

| Product ID | L (mm) Bolt Length | D (mm) Head Diameter | H (mm) Head Thickness | k (mm) Hexagon Across Flats | t (mm) Groove Depth | Screwdriver Bit Size |
|------------|-----------------------|-------------------------|--------------------------|-----------------------------------|------------------------|----------------------|
| AA064 | 6 | 7.6 | 2.2 | 2.5 | 1.3 | H2.5 |
| AA065 | 8 | 7.6 | 2.2 | 2.5 | 1.3 | H2.5 |
| AA175 | 10 | 7.6 | 2.2 | 2.5 | 1.3 | H2.5 |
| AA066 | 12 | 7.6 | 2.2 | 2.5 | 1.3 | H2.5 |
| AA176 | 14 | 7.6 | 2.2 | 2.5 | 1.3 | H2.5 |
| AA067 | 16 | 7.6 | 2.2 | 2.5 | 1.3 | H2.5 |
| AA177 | 18 | 7.6 | 2.2 | 2.5 | 1.3 | H2.5 |
| AA068 | 20 | 7.6 | 2.2 | 2.5 | 1.3 | H2.5 |
| AA069 | 25 | 7.6 | 2.2 | 2.5 | 1.3 | H2.5 |
| AA070 | 30 | 7.6 | 2.2 | 2.5 | 1.3 | H2.5 |

*Compliant with the requirements of GB/T 70.2 - 2015 standard [Equivalent standards: ISO 7380-1 - 2011, DIN EN ISO 7380 (-1) - 2011]

Basic Information

| | | | |
|---------------------|-----------------|-------------------|---------------|
| Surface Treatment | No | Material | Carbon steel |
| Mounting Hole Shape | Hex socket | Thread Ridge Type | Metric coarse |
| Screw Type | Complete thread | Color | Silver |

Product Feature

- Carbon Steel Button Head Cap Machine Screws (BHCS)
- Nominal thread: M2-M4
- Strength rating: 4.8
- Full thread series
- Type of thread: Metric coarse thread

M4 半圆头机牙螺丝

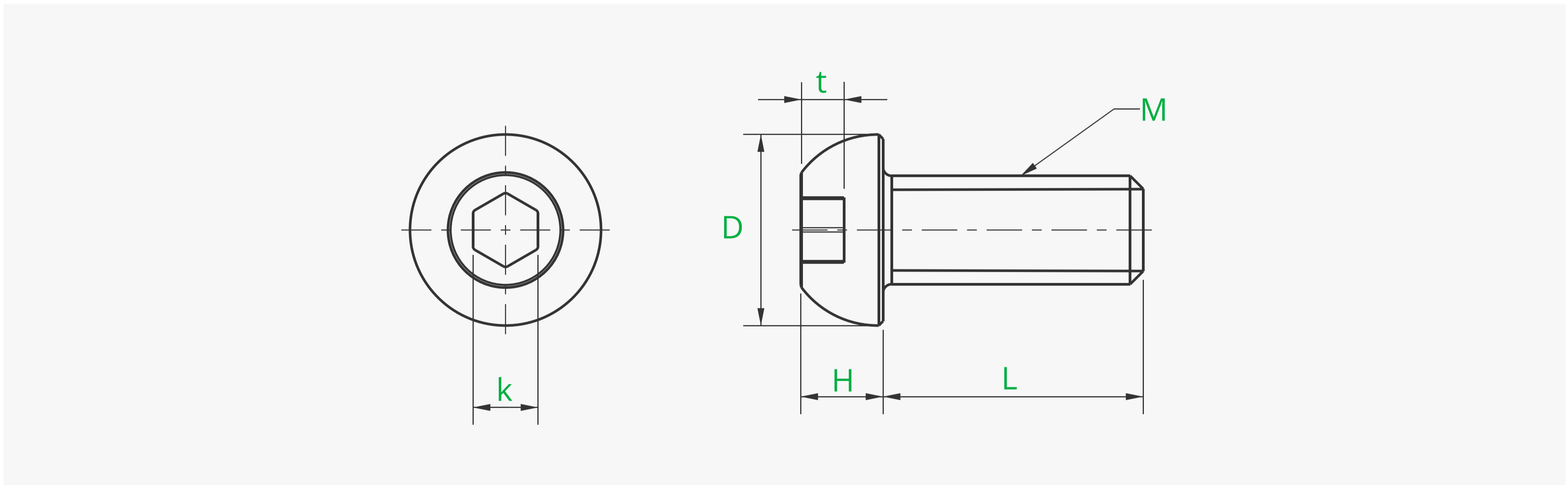

| 产品ID | 螺栓长度L (mm) | 头部直径D (mm) | 头部厚度H (mm) | 六角对边距k (mm) | 槽深t (mm) | 适配批头 |
|-------|---------------|---------------|---------------|----------------|-------------|------|
| AA064 | 6 | 7.6 | 2.2 | 2.5 | 1.3 | H2.5 |
| AA065 | 8 | 7.6 | 2.2 | 2.5 | 1.3 | H2.5 |
| AA175 | 10 | 7.6 | 2.2 | 2.5 | 1.3 | H2.5 |
| AA066 | 12 | 7.6 | 2.2 | 2.5 | 1.3 | H2.5 |
| AA176 | 14 | 7.6 | 2.2 | 2.5 | 1.3 | H2.5 |
| AA067 | 16 | 7.6 | 2.2 | 2.5 | 1.3 | H2.5 |
| AA177 | 18 | 7.6 | 2.2 | 2.5 | 1.3 | H2.5 |
| AA068 | 20 | 7.6 | 2.2 | 2.5 | 1.3 | H2.5 |
| AA069 | 25 | 7.6 | 2.2 | 2.5 | 1.3 | H2.5 |
| AA070 | 30 | 7.6 | 2.2 | 2.5 | 1.3 | H2.5 |

*符合GB/T 70.2 - 2015标准要求[等效标准: ISO 7380-1 - 2011、DIN EN ISO 7380 (-1) - 2011]

基本信息

| | | | |
|------|------|------|-------|
| 表面处理 | 无 | 材质 | 碳钢 |
| 批头种类 | 内六角 | 螺纹牙形 | 公制 粗牙 |
| 牙长 | 全螺纹型 | 表面颜色 | 银色 |

产品特点

- 碳钢半圆头机牙螺丝
- 螺纹公称: M2-M4
- 强度等级: 4.8
- 全牙系列
- 螺纹牙形种类: 公制粗牙