

M3 Socket Head Shoulder Machine Screws (SHSS)

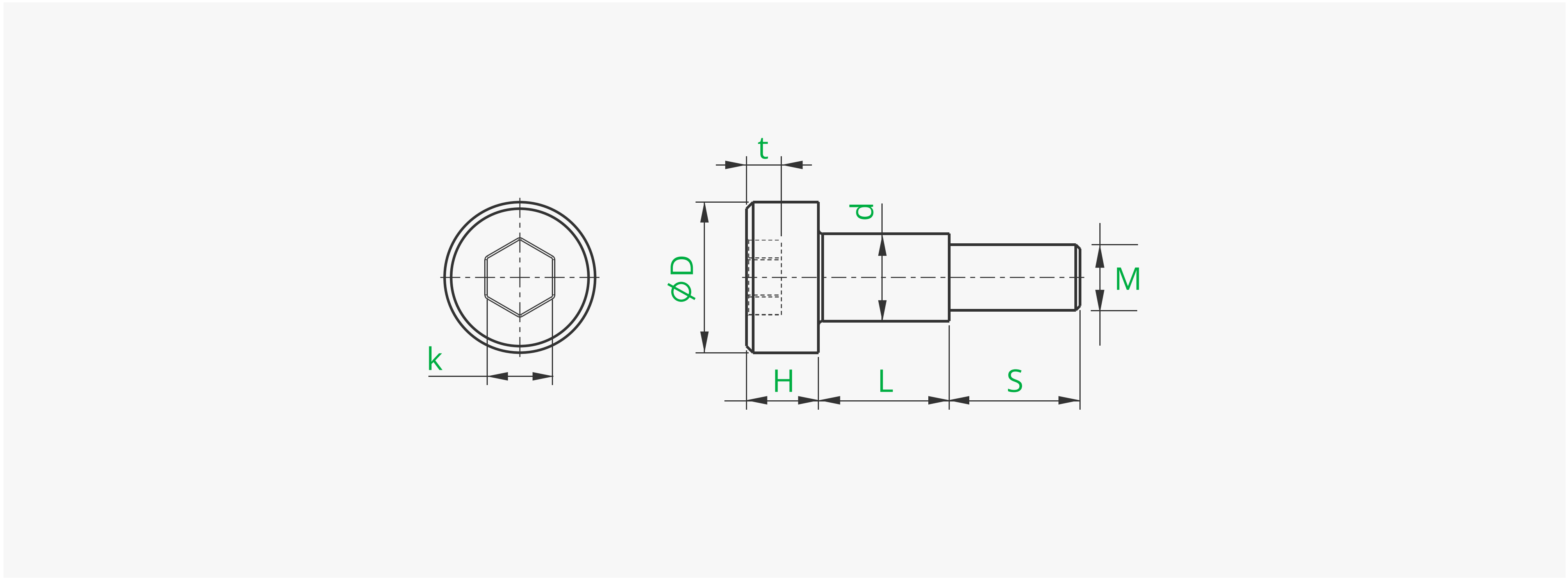

Product ID	L (mm) Shoulder Length	d (mm) Shoulder Diameter	S (mm) Thread Length	D (mm) Head Diameter	H (mm) Head Thickness	k (mm) Hexagon Across Flats	t (mm) Groove Depth	Screwdriver Bit Size
AA208	5	4.0	6.0	6.9	3.5	3.0	1.5	H3
AA121	6	4.0	6.0	6.9	3.5	3.0	1.5	H3
AA122	8	4.0	6.0	6.9	3.5	3.0	1.5	H3
AA209	10	4.0	6.0	6.9	3.5	3.0	1.5	H3
AA123	12	4.0	6.0	6.9	3.5	3.0	1.5	H3
AA210	14	4.0	6.0	6.9	3.5	3.0	1.5	H3
AA124	16	4.0	6.0	6.9	3.5	3.0	1.5	H3
AA211	18	4.0	6.0	6.9	3.5	3.0	1.5	H3
AA125	20	4.0	6.0	6.9	3.5	3.0	1.5	H3
AA126	25	4.0	6.0	6.9	3.5	3.0	1.5	H3
AA127	30	4.0	6.0	6.9	3.5	3.0	1.5	H3

*Compliant with the requirements of GB 5281 - 1985 standard [Equivalent standards: ISO 7379 - 1983]

Basic Information

Surface Treatment	Zinc-nickel alloy plating	Material	Carbon steel
Mounting Hole Shape	Hex socket	Thread Ridge Type	Metric coarse
Screw Type	Half thread	Color	Silver

Product Feature

- Carbon Steel Socket Head Shoulder Machine Screws (SHSS)
- Strength grade: 4.8
- Half thread series
- Using a shoulder section as a bare shaft for easy mounting of bearings or other components

M3 圆柱头塞打螺丝

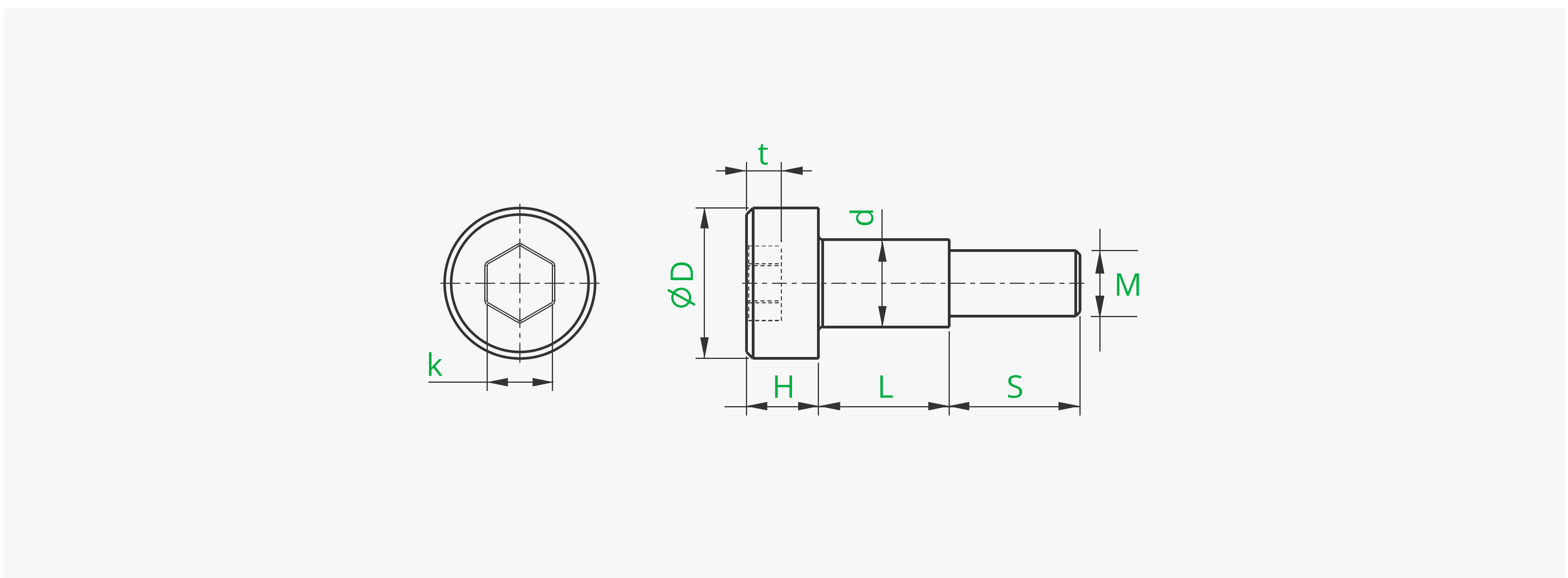

产品ID	轴肩长度L (mm)	轴肩直径d(mm)	螺纹长度S (mm)	头部直径D (mm)	头部厚度H (mm)	六角对边距k (mm)	槽深t (mm)	适配批头
AA204	5	4.0	6.0	6.9	3.5	3.0	1.5	H3
AA114	6	4.0	6.0	6.9	3.5	3.0	1.5	H3
AA115	8	4.0	6.0	6.9	3.5	3.0	1.5	H3
AA205	10	4.0	6.0	6.9	3.5	3.0	1.5	H3
AA116	12	4.0	6.0	6.9	3.5	3.0	1.5	H3
AA206	14	4.0	6.0	6.9	3.5	3.0	1.5	H3
AA117	16	4.0	6.0	6.9	3.5	3.0	1.5	H3
AA207	18	4.0	6.0	6.9	3.5	3.0	1.5	H3
AA118	20	4.0	6.0	6.9	3.5	3.0	1.5	H3
AA119	25	4.0	6.0	6.9	3.5	3.0	1.5	H3
AA120	30	4.0	6.0	6.9	3.5	3.0	1.5	H3

*符合GB 5281 - 1985标准要求 [等效标准: ISO 7379 - 1983]

基本信息

表面处理	镀锌镍合金	材质	碳钢
批头种类	内六角	螺纹牙形	公制粗牙
牙长	半螺纹型	表面颜色	银色

产品特点

- 碳钢圆柱头塞打（轴肩）螺丝
- 强度等级: 4.8
- 半牙系列
- 利用轴肩段作为光轴以轻松安装轴承等零件