

M2.5 Socket Head Cap Machine Screws (SHCS)

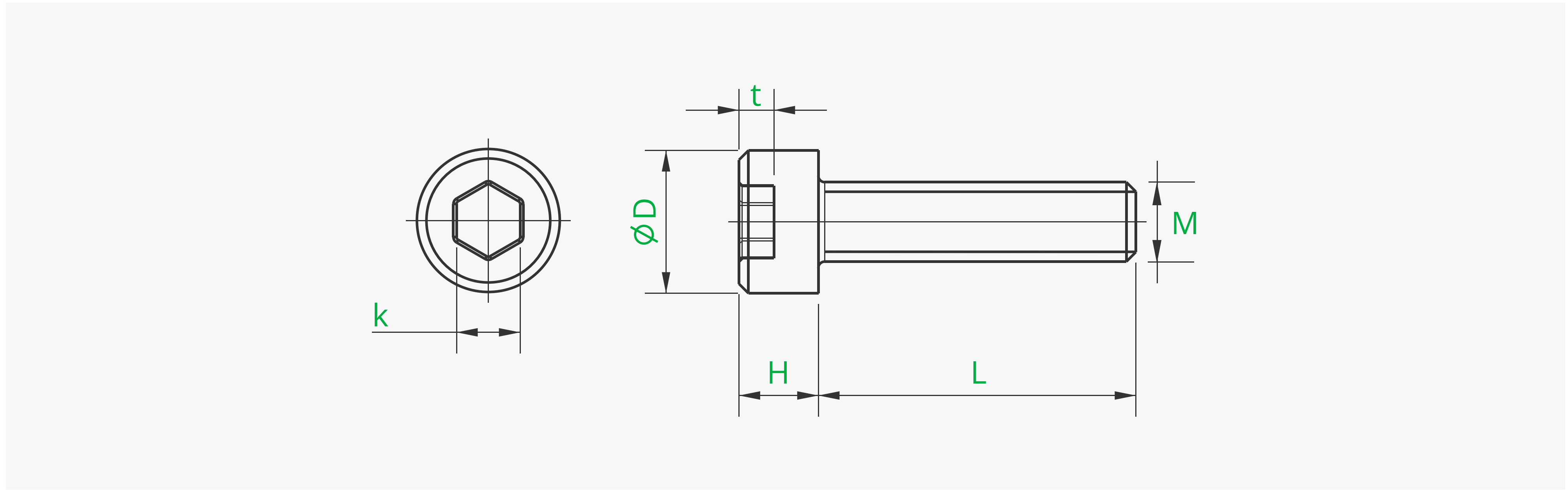

Product ID	M (mm) Nominal Diameter	P (mm) Thread Pitch	L (mm) Bolt Length	D (mm) Head Diameter	H (mm) Head Thickness	t (mm) Groove Depth	k (mm) Hexagon Across Flats	Screwdriver Bit Size
AA005	2.5	0.45	10	4.5	2.5	1.1	2	H2

*Compliant with the requirements of GB/T 70.1-2008 standard [Equivalent standards: ISO 4762, ASME/ANSI B 18.3.1M - 1986 (R1993), DIN EN ISO 12474]

Basic Information

Surface Treatment	No	Material	Stainless steel
Mounting Hole Shape	Hex socket	Thread Ridge Type	Metric coarse
Screw Type	Complete thread	Color	Silver

Product Feature

- Stainless Steel Socket Head Cap Machine Screws (SHCS)
- Nominal thread: M2.5~M5
- Strength grade: 4.8
- Full thread series (except M3*23)
- Type of thread: Metric coarse thread (currently all screws are metric coarse thread)

M2.5 圆柱头机牙螺丝

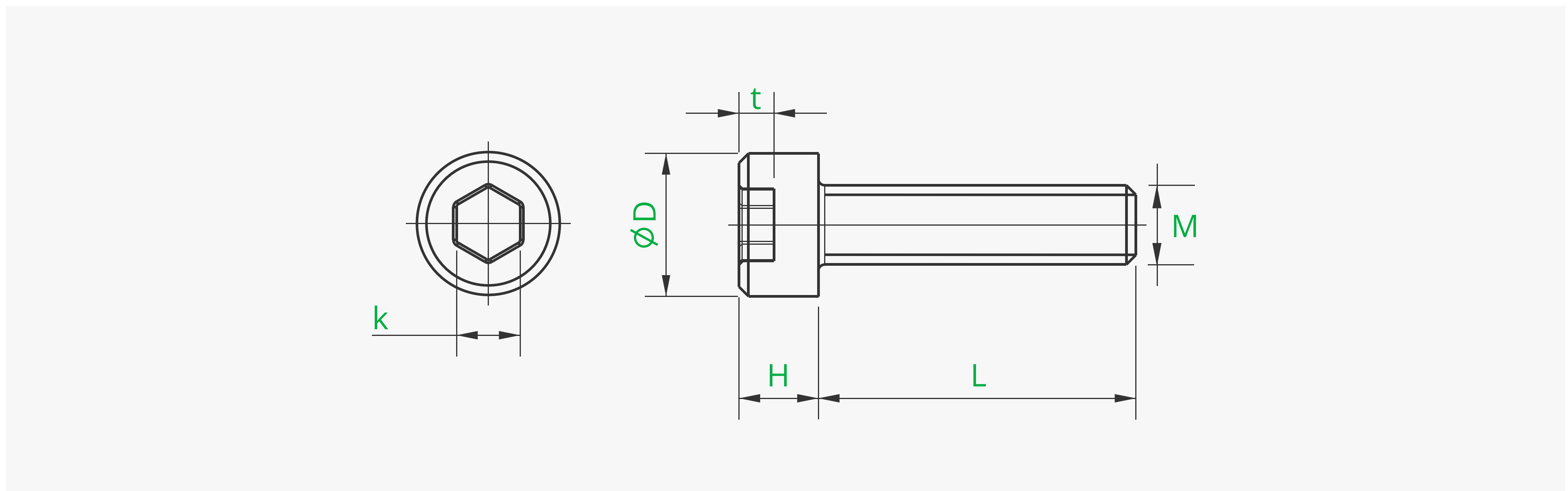

产品ID	公称直径M (mm)	螺距P (mm)	螺栓长度L (mm)	头部直径D (mm)	头部厚度H (mm)	槽深t (mm)	六角对边距k (mm)	适配批头
AA005	2.5	0.45	10	4.5	2.5	1.1	2	H2

*符合GB/T 70.1-2008标准要求 [等效标准: ISO 4762、ASME/ANSI B 18.3.1M - 1986 (R1993)、DIN EN ISO 12474]

基本信息

表面处理	无	材质	不锈钢
批头种类	内六角	螺纹牙形	公制粗牙
牙长	全螺纹型	表面颜色	银色

产品特点

- 不锈钢圆柱头机牙螺丝
- 螺纹公称: M2.5~M5
- 强度等级: 4.8
- 全牙系列 (除M3*23)
- 螺纹牙形种类: 公制粗牙 (目前所有的螺丝都为公制粗牙)