

M2 Button Head Cap Machine Screws (BHCS)

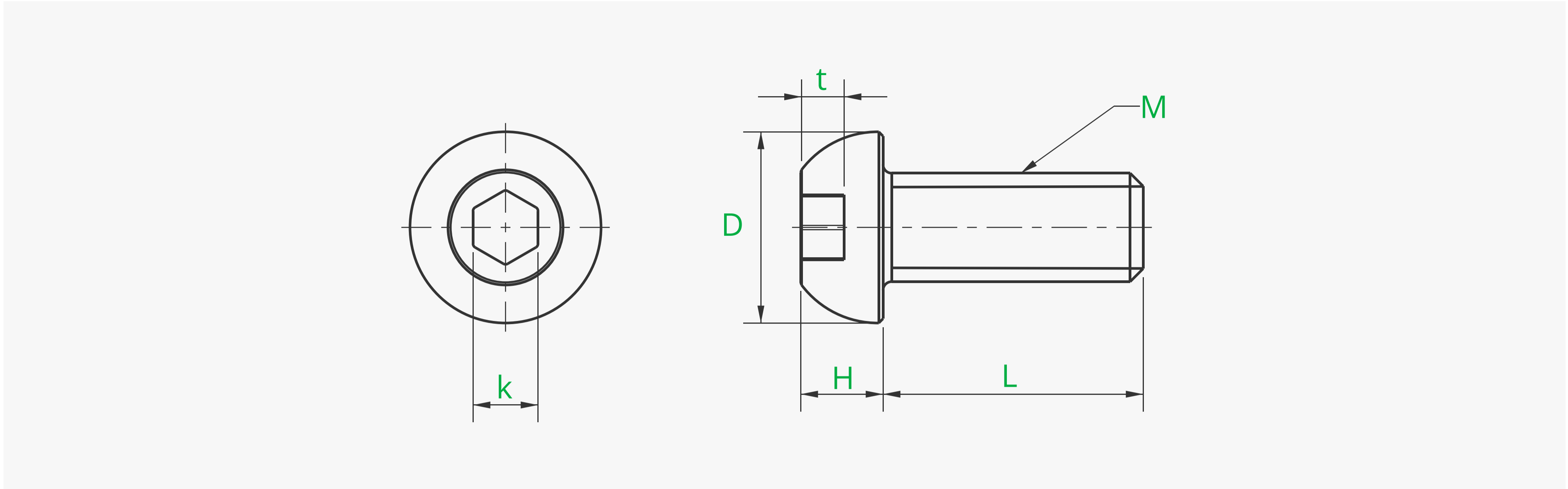

Product ID	L (mm) Bolt Length	D (mm) Head Diameter	H (mm) Head Thickness	k (mm) Hexagon Across Flats	t (mm) Groove Depth	Screwdriver Bit Size
AA162	4	3.5	1.3	1.3	0.6	H1.3
AA163	5	3.5	1.3	1.3	0.6	H1.3
AA043	6	3.5	1.3	1.3	0.6	H1.3
AA044	8	3.5	1.3	1.3	0.6	H1.3
AA164	10	3.5	1.3	1.3	0.6	H1.3
AA045	12	3.5	1.3	1.3	0.6	H1.3
AA165	14	3.5	1.3	1.3	0.6	H1.3
AA046	16	3.5	1.3	1.3	0.6	H1.3
AA166	18	3.5	1.3	1.3	0.6	H1.3
AA047	20	3.5	1.3	1.3	0.6	H1.3
AA048	25	3.5	1.3	1.3	0.6	H1.3
AA049	30	3.5	1.3	1.3	0.6	H1.3

*Compliant with the requirements of GB/T 70.2 - 2015 standard [Equivalent standards: ISO 7380-1 - 2011, DIN EN ISO 7380 (-1) - 2011]

Basic Information

Surface Treatment	No	Material	Carbon steel
Mounting Hole Shape	Hex socket	Thread Ridge Type	Metric coarse
Screw Type	Complete thread	Color	Silver

Product Feature

- Carbon Steel Button Head Cap Machine Screws (BHCS)
- Nominal thread: M2-M4
- Strength rating: 4.8
- Full thread series
- Type of thread: Metric coarse thread

M2 半圆头机牙螺丝

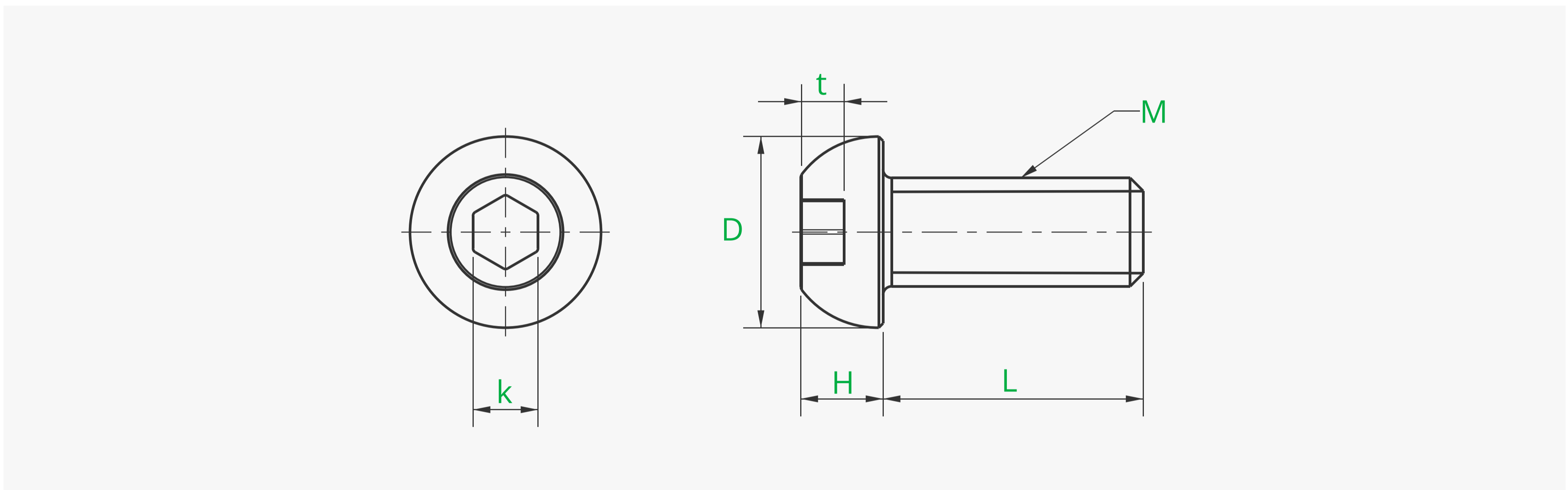

产品ID	螺栓长度L (mm)	头部直径D (mm)	头部厚度H (mm)	六角对边距k (mm)	槽深t (mm)	适配批头
AA162	4	3.5	1.3	1.3	0.6	H1.3
AA163	5	3.5	1.3	1.3	0.6	H1.3
AA043	6	3.5	1.3	1.3	0.6	H1.3
AA044	8	3.5	1.3	1.3	0.6	H1.3
AA164	10	3.5	1.3	1.3	0.6	H1.3
AA045	12	3.5	1.3	1.3	0.6	H1.3
AA165	14	3.5	1.3	1.3	0.6	H1.3
AA046	16	3.5	1.3	1.3	0.6	H1.3
AA166	18	3.5	1.3	1.3	0.6	H1.3
AA047	20	3.5	1.3	1.3	0.6	H1.3
AA048	25	3.5	1.3	1.3	0.6	H1.3
AA049	30	3.5	1.3	1.3	0.6	H1.3

*Compliant with the requirements of GB/T 70.2 - 2015 standard [Equivalent standards: ISO 7380-1 - 2011, DIN EN ISO 7380 (-1) - 2011]

基本信息

表面处理	无	材质	碳钢
批头种类	内六角	螺纹牙形	公制 粗牙
牙长	全螺纹型	表面颜色	银色

产品特点

- 碳钢半圆头机牙螺丝
- 螺纹公称: M2.0-M4
- 强度等级: 4.8
- 全牙系列
- 螺纹牙形种类: 公制粗牙