

BT2.5 Button Head Cap Self Tapping Screw (BHCS)

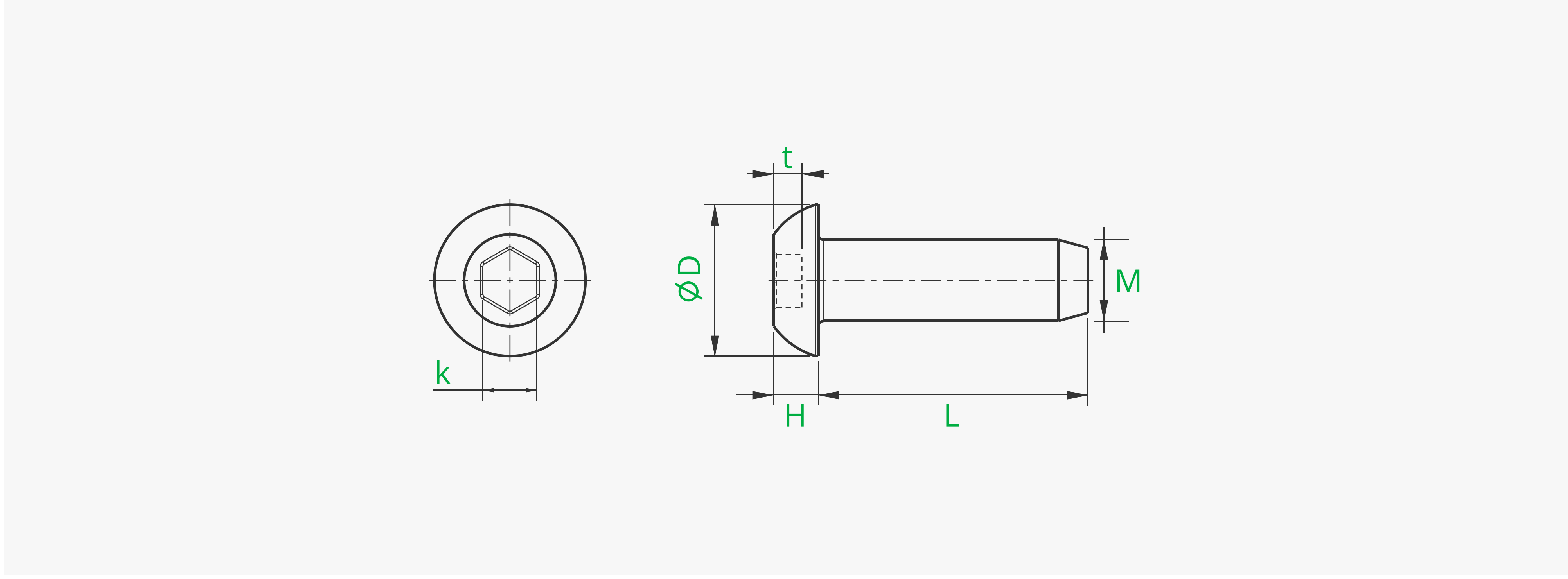

Product ID	L (mm) Bolt Length	D (mm) Head Diameter	H (mm) Head Thickness	k (mm) Hexagon Across Flats	t (mm) Groove Depth	Screwdriver Bit Size
AA217	5	4.7	1.5	1.5	0.8	H1.5
AA135	6	4.7	1.5	1.5	0.8	H1.5
AA136	8	4.7	1.5	1.5	0.8	H1.5
AA218	10	4.7	1.5	1.5	0.8	H1.5
AA137	12	4.7	1.5	1.5	0.8	H1.5
AA219	14	4.7	1.5	1.5	0.8	H1.5
AA138	16	4.7	1.5	1.5	0.8	H1.5
AA220	18	4.7	1.5	1.5	0.8	H1.5
AA139	20	4.7	1.5	1.5	0.8	H1.5
AA140	25	4.7	1.5	1.5	0.8	H1.5
AA141	30	4.7	1.5	1.5	0.8	H1.5

Basic Information

Surface Treatment	Black zinc-nickel alloy plating	Material	Carbon steel
Mounting Hole Shape	Hex socket	Thread Ridge Type	Metric coarse
Screw Type	Complete thread	Color	Black

Product Feature

- Self-Tapping Screws for 3D Printing
- Carbon Steel Button Head Cap Self Tapping Screw (BHCS)
- Nominal thread: BT2-BT3
- Strength grade: 4.8
- Type of thread: Metric coarse thread
- Full thread series

BT2 半圆头自攻螺丝

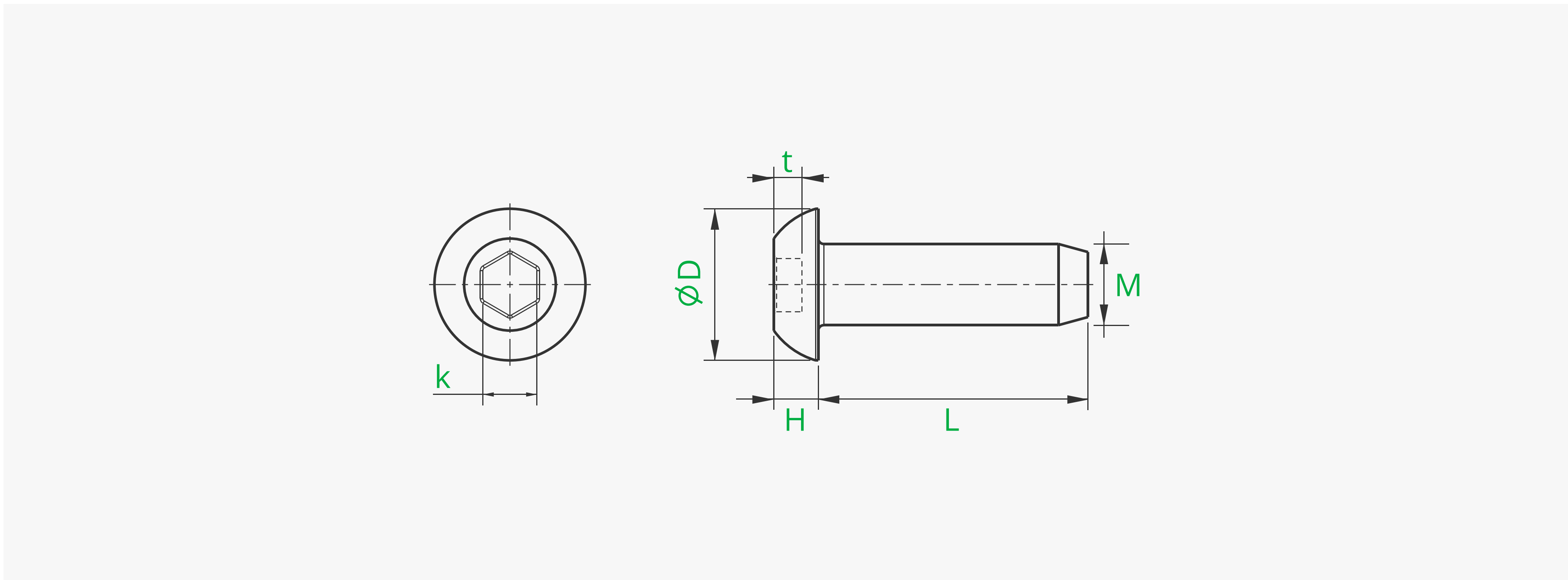

产品 ID	螺栓长度L (mm)	头部直径D (mm)	头部厚度H (mm)	六角对边距k (mm)	槽深t (mm)	适配批头
AA217	5	4.7	1.5	1.5	0.8	H1.5
AA135	6	4.7	1.5	1.5	0.8	H1.5
AA136	8	4.7	1.5	1.5	0.8	H1.5
AA218	10	4.7	1.5	1.5	0.8	H1.5
AA137	12	4.7	1.5	1.5	0.8	H1.5
AA219	14	4.7	1.5	1.5	0.8	H1.5
AA138	16	4.7	1.5	1.5	0.8	H1.5
AA220	18	4.7	1.5	1.5	0.8	H1.5
AA139	20	4.7	1.5	1.5	0.8	H1.5
AA140	25	4.7	1.5	1.5	0.8	H1.5
AA141	30	4.7	1.5	1.5	0.8	H1.5

基本信息

表面处理	镀黑色锌镍合金	材质	碳钢
批头种类	内六角	螺纹牙形	公制粗牙
牙长	全螺纹型	表面颜色	黑色

产品特点

- 3D打印优选自攻螺丝
- 碳钢半圆头自攻螺丝
- 螺纹公称: BT2-BT3
- 强度等级: 4.8
- 全牙系列
- 螺纹牙形种类: 公制粗牙