



# MUKKPET NINJA

## User Manual





# Contents

<b>Welcome to the Mukkpet !</b> .....	03
<b>Product Overview</b> .....	05
<b>Specification</b> .....	06
<b>Assembly Guidance</b> .....	07
- Package Content .....	07
- Assembly Steps .....	08
<b>Pre-ride Check</b> .....	13
<b>Battery</b> .....	14
- Battery Use .....	14
- How to Take Care The Battery .....	15
<b>Display and Setting</b> .....	16
- Parameter Setting .....	18
- Error Code Definition .....	20
<b>Operating Safety</b> .....	21
<b>FAQ</b> .....	22
<b>Component Maintenance</b> .....	24
- Battery Maintenance .....	24
- Frame Maintenance .....	24
- Brake Maintenance .....	25
- Motor Maintenance .....	25
- Tire Maintenance .....	25
- Derailleur Maintenance .....	25
<b>Warranty</b> .....	26
<b>Disclaimer</b> .....	28



# Welcome to the Mukkpet !

## Congratulations on your purchase of a new Mukkpet E-bike!

Thank you for choosing Mukkpet as your cycling companion! Please read and understand this manual thoroughly before assembling and cycling your ebike. The assembly video and other useful content about the ebike can be found in the QR code of this user guide.

Be sure to check that all steps are properly assembled, see "**Assembly Guidance**" on page 7. Before each ride, follow the advice in "**Pre-ride Check**" on page 13. Finally, maintain your ebike according to the "**Component Maintenance**" on page 24. If you are not sure you have the skills, experience, and special tools required for assembly and maintenance, get help from a local, certified, and reputable bike mechanic.

### We are here to help!

Feel free to contact us attached your order number, problem description, and image if you have any questions. All your questions will be replied to within 24 hours on working days.

Number: **562 556 9899** (9:00 am - 5:30 pm PST, Monday to Friday)

E-mail:

WhatsApp:



[support@mukkpetbike.com](mailto:support@mukkpetbike.com)



+86 17825804876

***Go with Mukkpet to enjoy your wonderful cycling journey!***

## NOTICE

**16<sup>+</sup>**

Riders must be at least 16 years old. For safety reasons, riders must comply with local regulations regarding rider age and other qualifications.



No matter riding any bicycle or electric bike, you must wear the helmet to protect personal safety.



Before each ride, please check your ebike according to the checklist in this manual. Failure to do so may result in property damage, serious injury or death.



**WARNING** Mukkpet E-bike LLC assumes no liability for any harm, injury, or death of the rider.

The bike comes 95% assembled and here is the guide that helps you get familiar with your new bike in unboxing. The bike may need adjustments in this process as shipping can some-times be bumpy. We recommend an adjustment and inspection by a reputable, certified bicycle mechanic before the first ride.

- Please read the whole manual patiently before you use the new electric bike.
- Do not modify or disassemble the original electrical components of the bike.
- This manual is not intended to be used as a detailed service manual. Please feel free to contact us if there is anything you would like to know.

# Product Overview

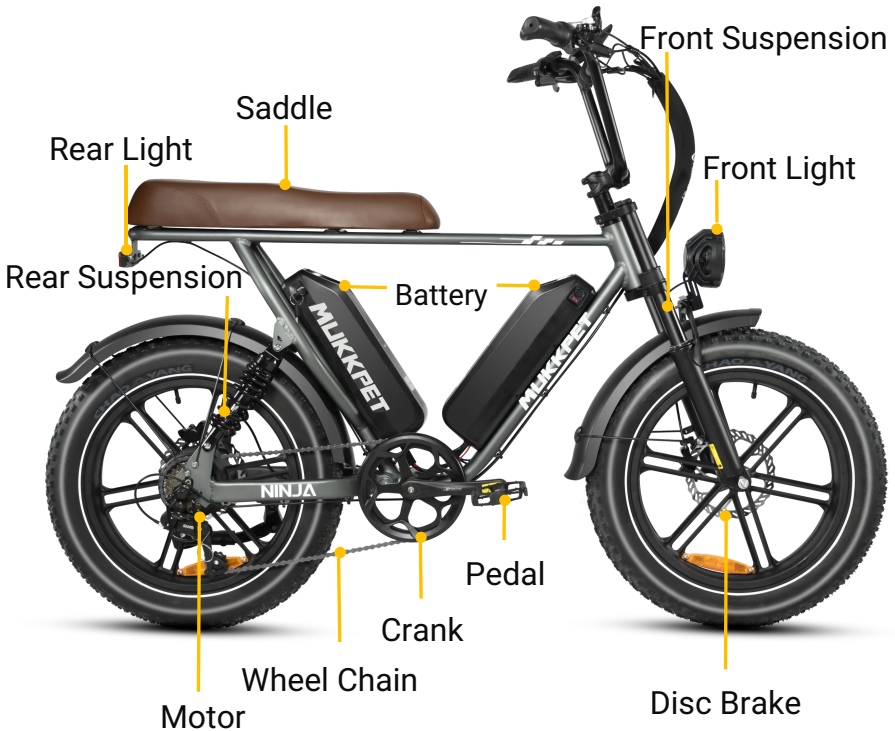
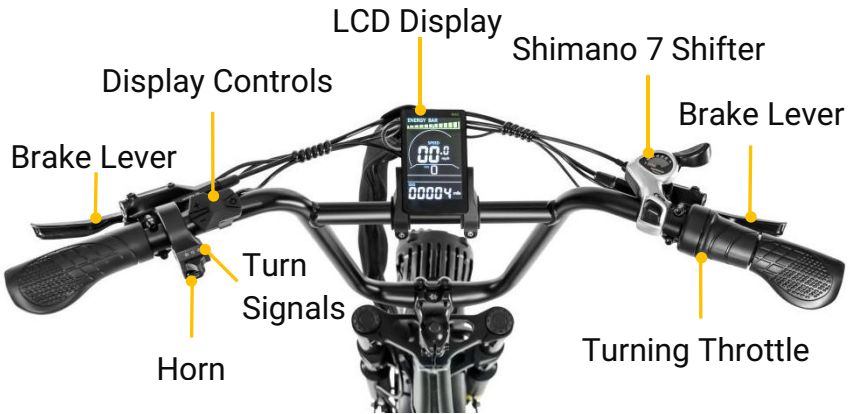

# Specification













Specification

Item	Specification
Model	NINJA
Product Dimensions	160*70*117CM 63*27.5*46IN
Package Dimensions	136.5*34.5*90CM 53.7*1.36*35.4IN
Max Load	300LBS
Package Weight	43KG
E-Bike Weight	38KG
Max Speed	28 MPH
Battery/Charger	48V15AH Input 100-240V 50/60Hz Output 54.6V 3A
Pedal-Assist Mode (Dual-Battery)	80-120Miles
Pure Electric Mode (Dual-Battery)	60-80Miles
Max Angle of Climb	30 Degrees
Charging Time	4-6 Hours(Single Battery)
Tire Pressure	20PSI
Frame Material	Aluminum Alloy



# Assembly Guidance

## • Package Content

			
Electric Bike*1	User Manual*1	Tool Kit*1	Tool Bag*1
			
Front Wheel*1	Pedals*2	Display*1	Charger*1
			
Headlight*1	Fender*1	Front Axle*1	Battery*2

Please scan the following QR code to watch the assembly video.



<https://www.youtube.com/watch?v=zab0deo4kLw>

## • Assembly Steps

### Step 1: Handlebar



1. Use the allen wrench to unscrew the four screws on the face plate.



2. Center the handlebar and tighten the four handlebar stem faceplate bolts evenly and part way.



3. Adjust the handlebar to a position perpendicular to the front wheel and tighten the screws on the stem.

## Step 2: Display



1. Remove the screws from the display.



2. Attach the display to the handlebar and tighten the screws.

## Step 3: Front Wheel

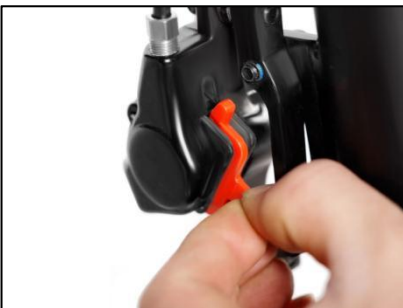

1. Remove fork protective cover and take out plastic insert from front wheel brake caliper.



2. Put the fork screw through the front wheel.



3. Carefully lift the front of the bike and lower the fork onto the wheel so that the brake rotor enters the caliper, between the brake pads, and the axle enters the fork dropouts fully.



4. Tighten the front wheel screws to secure the front wheel to the fork.

## Step 4: Fender/Headlight



1. Unscrew the corresponding screws on the front fork.



2. Install the fender/headlight mounting hardware through the headlight bracket, fender, and fork thread in the bolt to attach the fender mounting bracket to the mounting point on the back of the fork, then tighten securely.



3. Plug in the headlight connector. Line up the internal notch and pins and external arrows, and press directly together without twisting.

### Step 5: Pedals

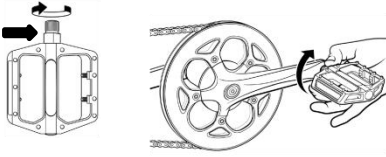

The right pedal is marked with an “R”, and has a smooth pedal axle.



The left pedal is marked with an “L”, and has notches on the pedal axle.

#### NOTICE

Gently by hand without cross-threading or damaging the threads.

# Pre-ride Check

1. Make sure all components are tightened. Adjust the height of the handlebar and the seat post. **DO NOT** raise it above the safety line.
2. Make sure the brakes can cut off the power supply to the motor, and whether it is sensitive and reliable.
3. Make sure the display, brakes and lights can work properly.
4. Make sure the chain is tight.
5. Make sure the pedals and all the connection parts are firm and would not loose, and whether the crank is flexible without jamming.
6. Make sure the front and rear tire pressure and tire wear are suitable for your journey ahead.
7. Make sure the throttle works well without jamming, and whether it feels tight or loose when pressing the throttle.
8. Make sure the battery has been locked.



# Battery

## NOTICE

Before turning on the bike, please turn the key to the correct position to ensure that the battery is active.

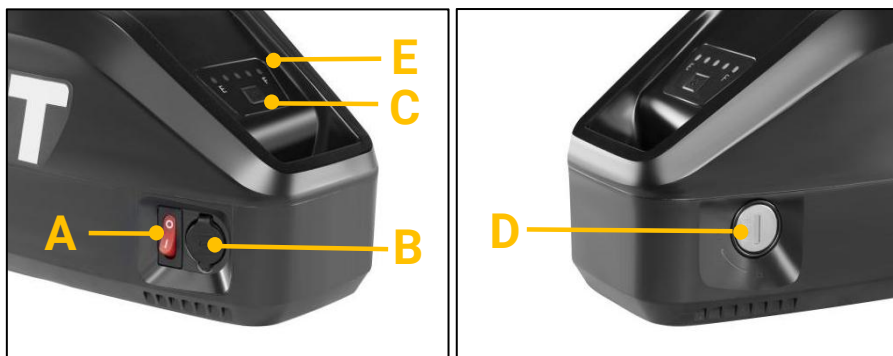
## • Battery Use



A	Battery On/Off switch (O--OFF; I--ON)
B	Battery charging port
C	Battery button (activates charge-level lights)
D	Key (  : Battery not can be removed, key can be removed.  : Battery can be removed, key not can be removed)
E	Charge-level lights

## NOTICE

Two charging ways: The first is to remove the battery and charge it. The second is to directly plug the charging cable into the charging port on the frame.



## • How to Take Care The Battery

### NOTICE

Check the charger, charger cables, and battery for damage before each charge. The charger shows red during charging, and it would turn green when the battery is fully charged.

1. Always charge in a safe area that is cool, dry, indoors, away from direct sunlight, dirt, or debris, in a clear area away from the potential to trip on the charging cords, or for damage to occur to the bike, battery, or charging equipment while parked and/or charging. Always charge your battery in temperatures between 50°F~77°F (10°C~25°C).
2. The battery can be charged on or off the bike. Keep the battery charged once a week even if you are not in use in case any defective issue occurs.
3. The battery should be recharged after each use, so it is ready to go the full range per charge next ride. There is no memory effect, so charging the battery after short rides will not cause damage.
4. Charging the battery normally takes 4-6 hours (single battery). In rare cases, it may take longer to allow the battery management system to balance the battery, particularly when the bike is new or after long periods of storage.
5. Never charge a battery for more than 12 hours at a time.
6. Do not leave a charging battery unattended.

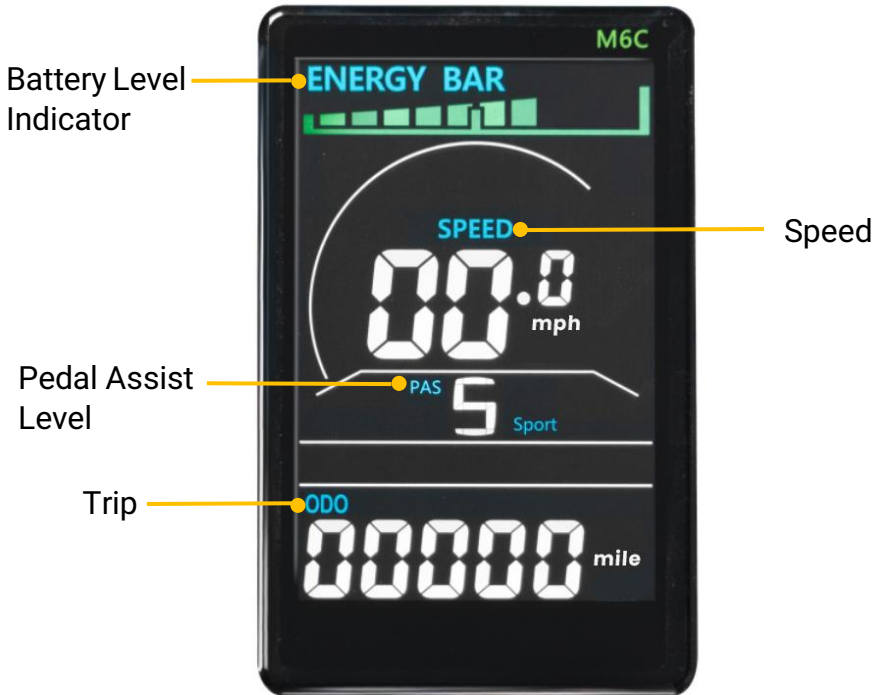

# Display and Setting

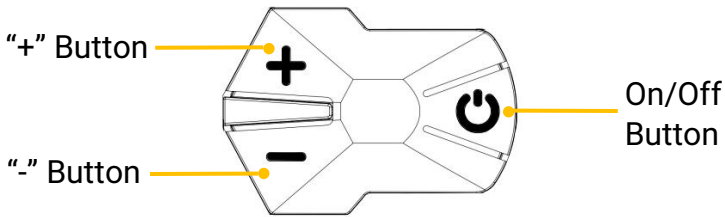

Display and Setting

<b>Battery Level Indicator</b>	Remaining battery power
<b>Speed</b>	Real time speed while riding
<b>Pedal Assist Level</b>	0,1,2,3,4,5 Displays the current pedal assisted mode.
<b>Trip</b>	Shows the distance of a single trip. Data is automatically cleared when the bike is powered off.
<b>Miles</b>	Speedometer units (KPH or MPH)



Common Operation	How to Do
Turn on/off the bike	Press and hold the “  ” for 3 seconds till the display is on / off.
Increase/Decrease the PAS Level	Press "+" or "-" button to increase or decrease the PAS Level.
Speed Switch	Long press “  ” and “+” to switch different speed information. Real Time Speed → Max Speed→Average Speed.
ODO/TRIP/VOL/CUR/ERROR/TM Switch	Short press “  ” to switch ODO (Total Mileage) → TRIP (Single Mileage) → VOL (Current Battery Voltage) → CUR (Current working current)→ERROR (Error Code)→TM (Display Startup Time).
Headlight Control	Long press "+" for 3 seconds to turn on/off the headlight.

## ● Parameter Setting

When the display is powered on, long press “+ ” and “ - ” at the same time, then will enter parameter setting mode. In this mode, you can change parameter values according to “ + ” or “ - ”. Short press “  ” will enter the next parameter setting.

Long press “ + ” and “ - ” again to exit the settings and save the parameters. If no operation within 8 seconds, it will exit and save the changed parameters automatically.

Set Mode	Operate	Note
P01: Back light lightness	Short press "+" / "-" will switch from 1 to 3. Level 3 is lightest, Level 2 is default value and level 1 is darkest.	
P02: Switch KPH/MPH	Short press "+" / "-" to switch KPH/MPH.	0: KM 1: MILE
P03: Working voltage	Short press "+" / "-" to switch the working voltage.	Available voltage— 24V, 36V, 48V, 60V
P04: Auto shutdown time	Short press "+" / "-" to switch from 0 to 60, it is the time to shut down the screen automatically. (Range: 1~60 minutes)	For example, when you set it to 10, it means that the shutdown time is 10 minutes.
P05: PAS mode setting	Short press "+" / "-" to adjust PAS mode.	0: 3 PAS mode 1: 5 PAS mode

Set Mode	Operate	Note
P06: Wheel size selection	Short press "+" / "-" to switch wheel size	0: 16 inch 4: 24 inch 1: 18 inch 5: 26 inch 2: 20 inch 6: 700C 3: 22 inch 7: 28 inch
P07: Number of magnets for speed sensor	Short press "+" / "-" to switch from 1 to 15.	
P08: Speed limit	Short press "+" / "-" to set the speed limit from 10 to 41km/h.	
P09~P15: This feature is blank, invalid.		
P16: Reset ODO distance	Long press "+" during 5 seconds to reset the ODO distance.	
P17: This feature is blank, invalid.		
P18: Speed ratio adjustment	Short press "+" / "-" to set the speed ratio from 50%~150%. The default value is 100%.	
P19: Is the 0 PAS displayed	Short press "+" / "-" to set the value.	0: Contains 0 PAS 1: Excluding 0 PAS
P20~P26: This feature is blank, invalid.		

## • Error Code Definition

When an error appears, M6C will notice users by different codes, please refer to the table for different codes:

Code ( Decimal )	Signification
E33	Current anomaly
E34	Turn handle anomaly
E35	Motor phase deficiency
E37	Brake anomaly
E30	Communication anomaly

### NOTICE

The display has generally been set to a normal state, and it is recommended not to modify the data of the display without special requirements.

# Operating Safety

1. This E-bike will power off when braking. It ensures the safety of riding.
2. The max weight capacity of the ebike is **300LBS**.
3. Don't ride exceed the speed limit set by the local traffic laws. Comply with the **CLASS 1** maximum speed limit: **20MPH**.
4. Always wear a helmet that meets the standards and make sure to have the necessary protection to ensure safety when riding the E-bike.
5. Turn on the headlight when riding at night. Using the headlight for a long time will consume part of the electric energy and reduce the mileage.
6. Avoid pressing the throttle frequently and rapidly to start the E-bike when stationary to extend the service life of the motor, battery and electrical components.
7. Turn off the display when parking or leaving the E-bike to prevent accidents caused by accidentally turning the throttle and the E-bike suddenly moving.

# FAQ

**Q: What if the battery cannot be charged, and the display shows an abnormal battery power?**

A: Use a multimeter to test the battery voltage. Check if the charger indicator is normal. (Red light means charging, green light means fully charged) If the battery case is damaged, stop using the battery and contact us.

**Q: How should I do if the rear wheel motor makes abnormal noise?**

A: Lift the rear wheel off the ground and press the throttle to see if the rear works. Then contact us with a video for further solutions.

**Q: Can I refit the bike?**

A: The bike can be disassembled and refitted. But our warranty will not cover any bike problems after the refit.

**Q: Can I ride in the rain?**

A: Do not ride on rainy days, and it is forbidden to ride in heavy rain. Add protection to the display if you ride on rainy days. The warranty will not cover the display problems caused by water damage.

**Q: What if the tires got flat or could not be inflated?**

A: The tires will not be filled with air. Ride the bike after inflating the tires. Please check if there is a hole in the inner tube and if there is something sharp puncturing the inner tube.

**Q: I need to return the e-bike, what should I do?**



A: If you need to return the e-bike, please contact the Mukkpet customer support team within 14 days of purchase.

**Q: What if the brakes make abnormal noise?**

A: Adjust the brake pads or brake discs, or you can contact us directly.

**Q: What if the bike won't turn on?**

A: Make sure the battery has been fully charged and reconnect the display cable to see if it could work, or you can contact us directly.

**Q: What if the e-bike arrived missing an accessory or broken part?**

A: Please take a photo and send it to Mukkpet ebike support team by sending e-mail: [support@mukkipetbike.com](mailto:support@mukkipetbike.com) and Mukkpet e-bike support team will reply to you soon and send the correct accessory or part replacement.

**Q: What can I do if something goes wrong with my e-bike during the warranty?**

A: We believe that communication is the best way to solve the problem. Please contact us in time. To help you solve the problem as quickly as possible, please describe the problem in detail and provide photos / videos with your order number.

# Component Maintenance

## ● Battery Maintenance

- Fully charge the battery for the first use. (more than 6 hours)
- Do not use the battery at a low power level.
- Must use the specified charger for charging.
- Do not charge the battery at high temperatures (over 212 Fahrenheit /100°C). Charge at the ventilating place.
- If the battery is not in use for a long time, charge the battery at least once a month to keep the battery active.
- Keep the battery away from water or any other liquid.
- Turn off the battery when not in use.
- Fully charged the battery before use each time. It will extend the battery life.
- If there are problems with the battery, do not charge it anymore and contact us for further solutions.

## ● Frame Maintenance

- Pay attention to frame maintenance. Wipe the bike and keep it dry.
- Any merchandise with electrical components is not recommended to be exposed to water and the warranty of the Mukkpet does not cover water damage. So please try not to store or use the bike in wet condition.

## ● Brake Maintenance

- Check brake pads regularly.
- Check the brake disc regularly to prevent deform.
- If it is a hydraulic brake, check regularly to see if any oil leakage.
- Clean the brake regularly.

## ● Motor Maintenance

- Do not try to disassemble the motor.
- If there is any problems with the motor, contact us with videos.

## ● Tire Maintenance

- Check regularly to prevent air leak.
- Check spokes regularly.

## ● Derailleur Maintenance

- Check the rear derailleur regularly to see if it changed to every gear normally (contact us for the video about how to adjust the shifter).
- Check the rear derailleur guard to see whether it bent to affect the derailleur or not.

# Warranty

The main parts of the warranty provisions.

Component	Warranty Period	Performance Failure	Remark
Front fork handlebar	1 Year	<ul style="list-style-type: none"> <li>❖ Natural sealing off.</li> <li>❖ Fracture key parts crack.</li> </ul>	Except damaged caused by riders.
Motor	1 Year	<ul style="list-style-type: none"> <li>❖ Internal gear break.</li> <li>❖ Bearing broken.</li> <li>❖ The wheel hub shell cracking.</li> <li>❖ Coil burned.</li> <li>❖ Magnets off.</li> <li>❖ Clamping stagnation or have strange noise.</li> </ul>	Except damaged caused by rider.
Charger	1 Year	<ul style="list-style-type: none"> <li>❖ Does not work.</li> </ul>	Disassemble personally will not be replaced.
Controller	1 Year	<ul style="list-style-type: none"> <li>❖ Short circuit or open circuit.</li> <li>❖ Burnout.</li> <li>❖ Mousse tube damaged.</li> </ul>	Disassemble personally will not be replaced.
Battery	1 Year	<ul style="list-style-type: none"> <li>❖ Not working.</li> </ul>	Disassemble personally will not be replaced.
Display	1 Year	<ul style="list-style-type: none"> <li>❖ Not working.</li> </ul>	Disassemble personally will not be replaced.

## NOTICE

If you need to return or exchange the e-bike, please contact us within 14 days after receiving the item!

- The battery warranty does not include damage from power surges, use of 3rd party charger, improper maintenance or other such misuse, normal wear, or water damage (including rust).
- Stolen bikes are not covered under warranty. Necessary precautions must be taken to ensure the bike and battery are not exposed to severe weather conditions. Exposure to very wet, hot, or cold conditions may invalidate the warranty.
- Items including the chain, tires, wheels, tubes, battery handle, brake pads, cables and housing, grips, and spokes are considered wear items. These items wear down with normal use and are not covered under warranty.
- We will replace any parts deemed to have been damaged during shipping. Shipping damage must be reported to Mukkpet E-bike within 14 days of shipment arrival. This applies to all products including bikes and accessories. Replacement parts will not be sent until photographic evidence has been provided to Mukkpet E-bike.
- Mukkpet E-bike may request additional documentation (such as video) to assist with accurately diagnosing the problem and processing the **warranty claim**.

# Disclaimer

1. We will replace any parts deemed to have been damaged during shipping. Shipping damage must be reported to Mukkpet E-bike within **14 days** of shipment arrival. This applies to all products including bikes and accessories. Replacement parts will not be sent until photographic evidence has been provided to Mukkpet E-bike. Mukkpet E-bike may request additional documentation (such as video) to assist with accurately diagnosing the problem and processing the warranty claim.
2. For warranty services, please contact Mukkpet E-bike online support by email at [support@mukkipetbike.com](mailto:support@mukkipetbike.com). Bikes or parts returned without proper documentation may result in delayed service or denied warranty coverage. **All unauthorized returns will be refused.**
3. **Damage as a result of an accident is not covered under this warranty**, and Mukkpet E-bike is not responsible for the repair or replacement of damaged bikes or parts.
4. Mukkpet E-bike reserves the right to change its warranty at any time and without notice.
5. Under no circumstances is Mukkpet E-bike responsible for any damage resulting from damaged, defective, or improperly secured parts. This includes but is not limited to, damage to personal property, personal injury, or death.

**Contact us for more owner benefit.**



**E-mail:** [support@mukkipetbike.com](mailto:support@mukkipetbike.com)



**WhatsApp:** +86 17825804876



## **TIPS**

Please register your Mukkipet ebike for warranty on the "[https:// www.mukkipetbike.com](https://www.mukkipetbike.com)" after receiving it.  
Activate your Mukkipet ebike owner's benefit.

