

TOOLS REQUIRED FOR ASSEMBLY:
ADJUSTABLE WRENCH OR 10MM WRENCH
LARGE PHILLIPS HEAD SCREWDRIVER

HARDWARE

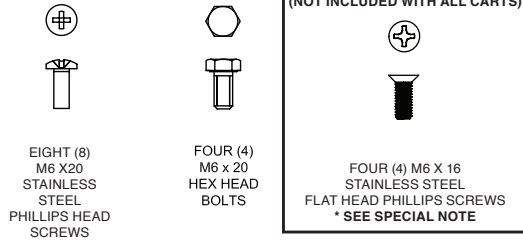

COMPONENTS

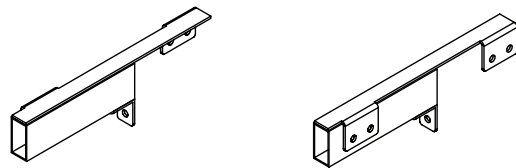

TWO (2)
LEFT HAND
SHELF BRACKETS

TWO (2)
RIGHT HAND
SHELF BRACKETS

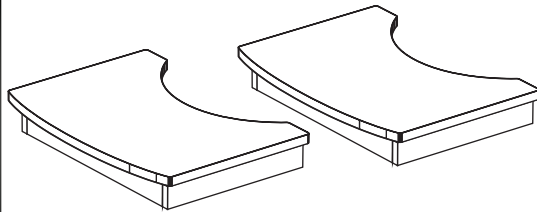

TWO (2)
ISLAND TOPS

ASSEMBLY INSTRUCTIONS

HANDLE METAL PARTS WITH CARE AS SOME MAY HAVE SHARP EDGES.

1. Remove all parts from the packaging and compare to the parts list.
2. SEE FIGURE 1 RIGHT. Remove 4 end caps prior to installation of shelf brackets if previously installed.
3. SEE FIGURE 2 BELOW. Install the 4 brackets to the frame of the cart with four M6 x 20 hex head bolts. (finger tighten only). *SEE SPECIAL NOTE BEFORE PROCEEDING.
4. SEE FIGURE 3 BELOW. Fit the island tops over the brackets and cart frame. For an Oval XL, use the outer most set of holes and for a Oval LG use the innermost set. The Oval JR shelf brackets have a single set of holes as seen in figure 4.
5. Adjust both the island top and brackets to align the openings in order to screw the island top to the cart. Being careful not to cross-thread the screws, finger tighten each of the 4 phillips head screws per island top before setting them tightly with the screwdriver.
6. Once the island top is installed, go back and tighten the brackets to the cart frame. DO NOT USE POWERED SCREWDRIVERS, DRILLS, OR IMPACT WRENCHES TO TIGHTEN THE BOLTS. This could result in damage to the cart or grommets.

STARTING POINT

NOTE: GRILL DOES NOT NEED TO BE REMOVED FROM CART TO PERFORM THIS INSTALLATION.

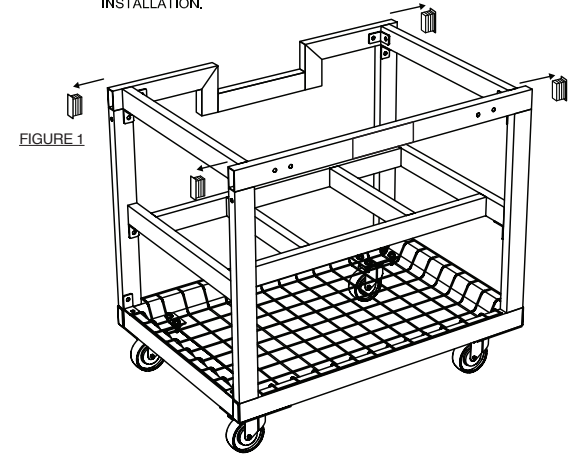

FULLY ASSEMBLED CART

*** SPECIAL NOTE :** Some carts ship with Shelf Brackets that have 3 holes facing the cart side (illustration below). Shelf brackets with a 3rd hole accept a M6x16 Phillips Head fastener that fastens through the outermost 3rd hole away from the center of the cart.

* NOTE: LG 300 & XL400 SHELF BRACKETS (TRIPLE HOLE)

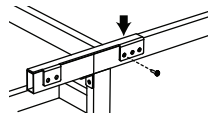

INSTALL THESE SCREWS BEFORE SIDE SHELF

FIGURE 4

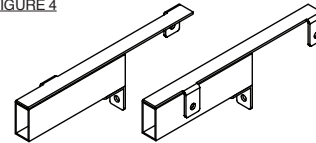

NOTE: JR 200 SHELF BRACKETS (SINGLE HOLE)

FIGURE 3

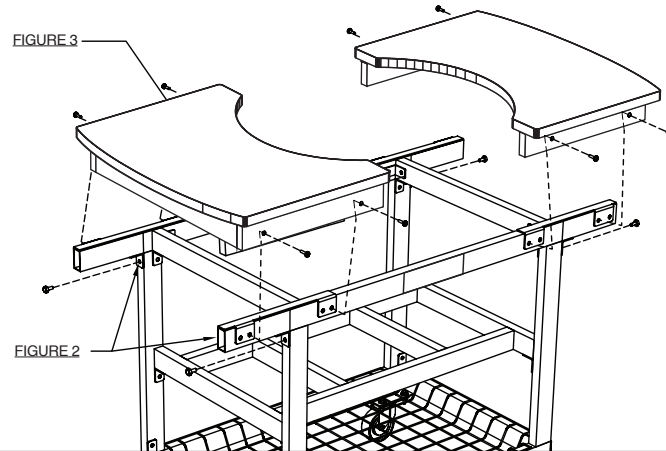
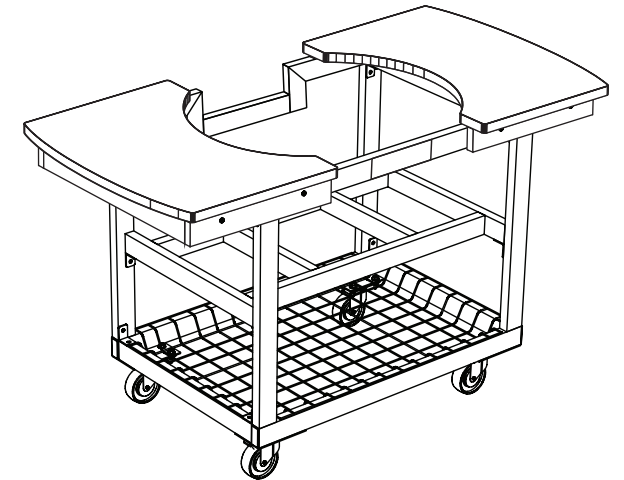

FIGURE 2



COMPLETED ASSEMBLY