

Alfresco™

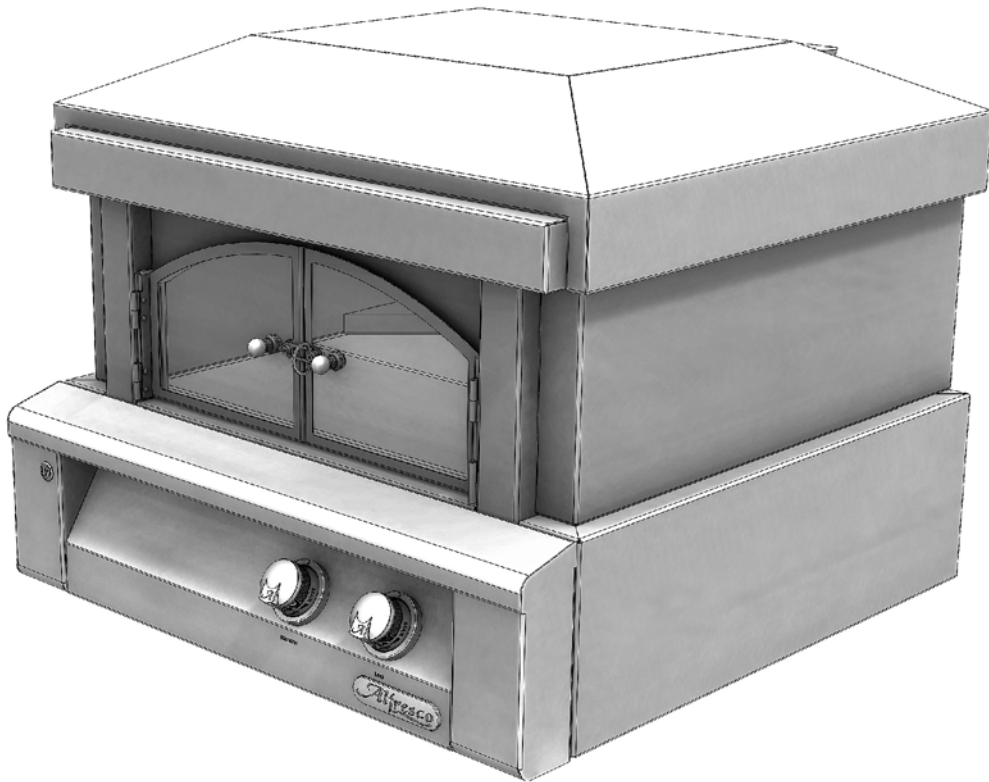

AXEPZA PIZZA OVEN PARTS MANUAL SERIAL N° 18-00000 FORWARD

BILL OF MATERIAL

NO.	PART #	DESCRIPTION	QTY.
1	100-2478	ALF-PZA SMOKER BOX	1
2	100-2828	AXE-PZA PIZZA STONE CENTER BRACKET	1
3	100-2845	PIZZA STONE BACK BRACKET FOR IGNITER	1
4	200-0395	THUMBSCREW 10-32 x 1/2 - WASHER HEAD- SS	2
5	290-0365	ALF-PZA CERAMIC WOOD LOG	1
6	290-0366	ALF-PZA BOTTOM PIZZA STONE	2
7	290-0367	ALF-PZA TOP REFRACTIVE STONE	1
8	510-0818	ALF-PZA GAS LOG SUPPORT ASSEMBLY	1
9	510-1092	AXE-PZA GAS MANIFOLD ASSEMBLY	1
10	510-1096	AXE-PZA FRONT PANEL MAIN ASSEMBLY	1
11	510-1097	AXE-PZA - GLASS DOORS ASSEMBLIES	1
12	510-1100	AXE-PZA OPENING ARCH ASSEMBLY	1
13	510-1101	AXE-PZA TOP CAP ASSEMBLY	1
14	510-1107	AXE-PZA MAIN BODY ASSEMBLY	1
15	510-1109	AXE-PZA ELECTRICAL COMPONENTS	1

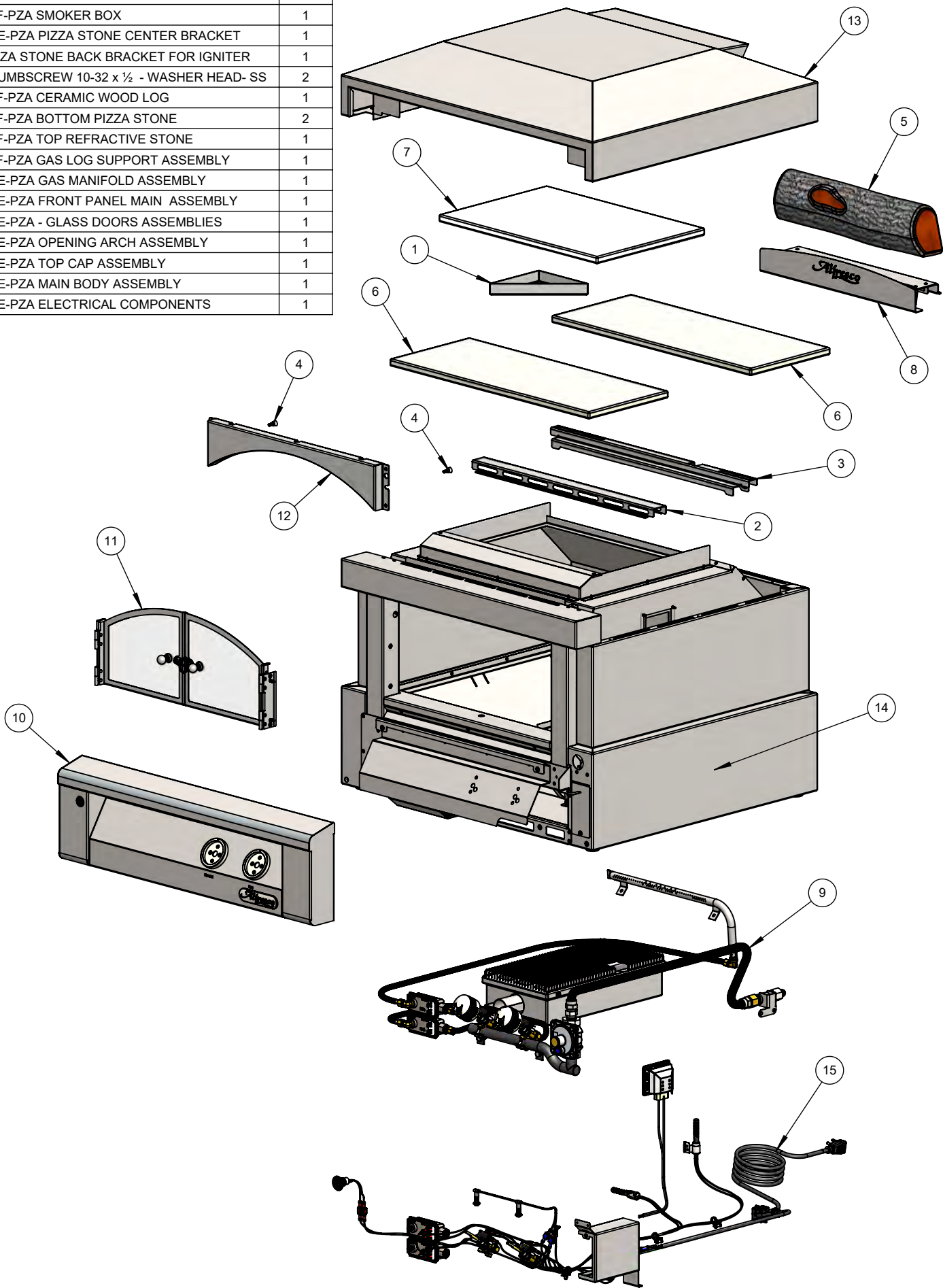

BILL OF MATERIAL

NO.	PART #	DESCRIPTION	QTY.
1	100-2830	AXE-PZA IR BURNER INLET CLOSEOFF	1
2	200-0087	WASHER, 1/4" - SPRING LOCK - SS	4
3	200-0089	BOLT - HEX HEAD 1/4-20 x 1/2" L	2
4	200-0219	SCREW 1/4-20 UNC X 5/8 LONG - HEX HD - SS	2
5	220-0280	REGULATOR GAS - MAXITROL RV48CL440002	1
6	220-0403	NIPPLE 3/8" OD FL x 1/2" FPT (FOR LP HOOK-UP)	1
7	220-0406	NIPPLE 1/2" OD FL x 1/2" MPT x 3/8" FPT	1
8	220-0408	NIPPLE 1/2" OD FL x 1/2" FPT	1
9	220-0458	BRACKET - GAS VALVE SADDLE MOUNT	2
10	220-0459	SCREW M5 x 26 - POZI•COMB•HEX HEAD- 11.5 PT	2
11	220-0473	MANIFOLD - CUSTOM	1
12	220-0474	ELBOW 1/8-27 UNS x 5/16" COMP	2
13	220-0474	ELBOW 90° - Ø 5/16" COMPRESSION X 3/8-27 UNS-2B	2
14	220-0477	GAS VALVE - SINGLE PORT 5/16" Ø COMP W/ SWITCH	2
15	220-0478	GAS LINE - FLEX - SS - 5/16"Ø x 8"	1
16	220-0480	GAS LINE - FLEX - SS - 5/16"Ø x 13"	1
17	220-0480	GAS LINE - FLEX - SS - 5/16"Ø x 13"	1
18	220-0481	GAS LINE - FLEX - SS - 5/16"Ø x 46"	1
19	220-0482	GAS LINE - FLEX - SS - ½ ODF x 32 in	1
20	220-0483	SAFETY GAS VALVE	2
21	220-0485	REDUCER 9/16-24 UNEF x 5/16" COMPRESSION - BRASS	2
22	290-0364	ALF-PZA (AXE-PZA) IR BURNER	1
23	290-0373	BACK BURNER	1
24	290-0453	ALFRESCO KNOB - MAX - MIN - Ø 6MM	2
25	510-1094	GAS INLET PIPING ASSY	1
26	SEE NOTE	LOG BURNER ORIFICE	1
27	SEE NOTE	IR-BURNER NOZZLE ORIFICE	1

REVISIONS

REV.	DESCRIPTION	DATE	BY
A	ADDED ITEM & CORRECTED ORIFICE #S	7/30/2019	AEC

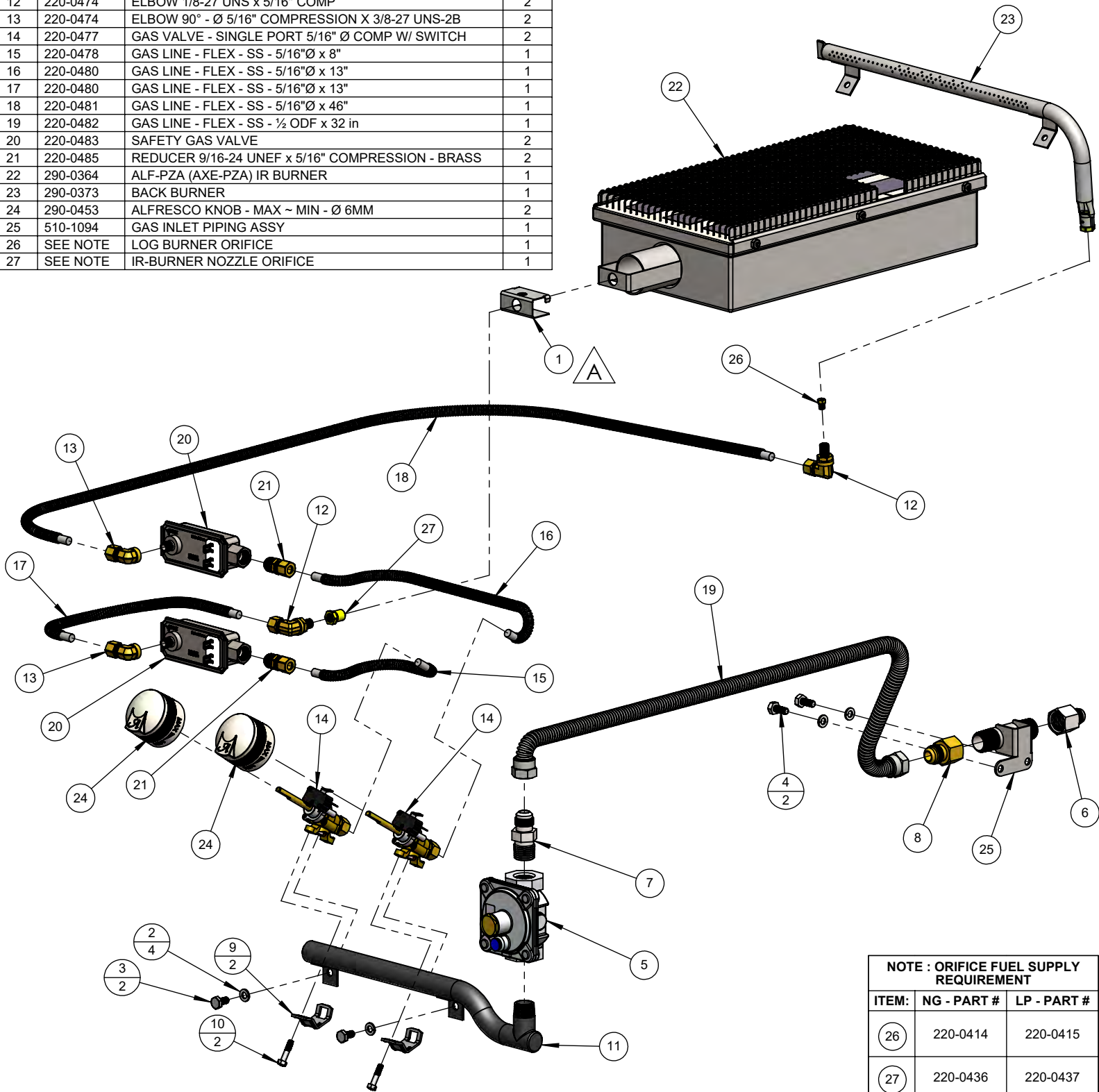

NOTE : ORIFICE FUEL SUPPLY REQUIREMENT

ITEM:	NG - PART #	LP - PART #
26	220-0414	220-0415
27	220-0436	220-0437

BILL OF MATERIAL

NO.	PART #	DESCRIPTION	QTY
1	200-0057	SCRW 1/4-20 X 1/2" - TRUSS HEAD PHILIPS	2
2	200-0075	# 10 LOCK WASHER	2
3	200-0087	WASHER, 1/4" - SPRING LOCK - SS	2
4	200-0089	BOLT - HEX HEAD 1/4-20 x 1/2" L	2
5	200-0125	NUT THREAD CUTTER FOR 1/4" Ø STUD -SPEED NUT	2
6	200-0267	SCREW 10-32 X 1/2 - PAN HEAD - PHILLIPS	2
7	200-0348	SCREW 6-32 x 3/8 - THREAD CUTTER - FLAT HEAD PHILIPS	4
8	210-0584	SWITCH - LIGHT - LATCHING [ON/OFF]	1
9	290-0377	ALFRESCO RANGE LOGO	1
10	290-0388	ALFRESCO RANGE KNOB - BEZEL RING	2
11	510-1095	AXE-PZA - FRONT PANEL WELDED PARTS	1
12	510-1102	BULLNOSE LIGHT ASSEMBLY	1
13	SEE NOTE	WASHER - LOCK - Ø 19 mm - INTERNAL TEETH	1
14	SEE NOTE	NUT - Ø 19 mm X 1	1

NOTE:
LOCK WASHER AND NUT ARE PART OF SWITCH (8) KIT.

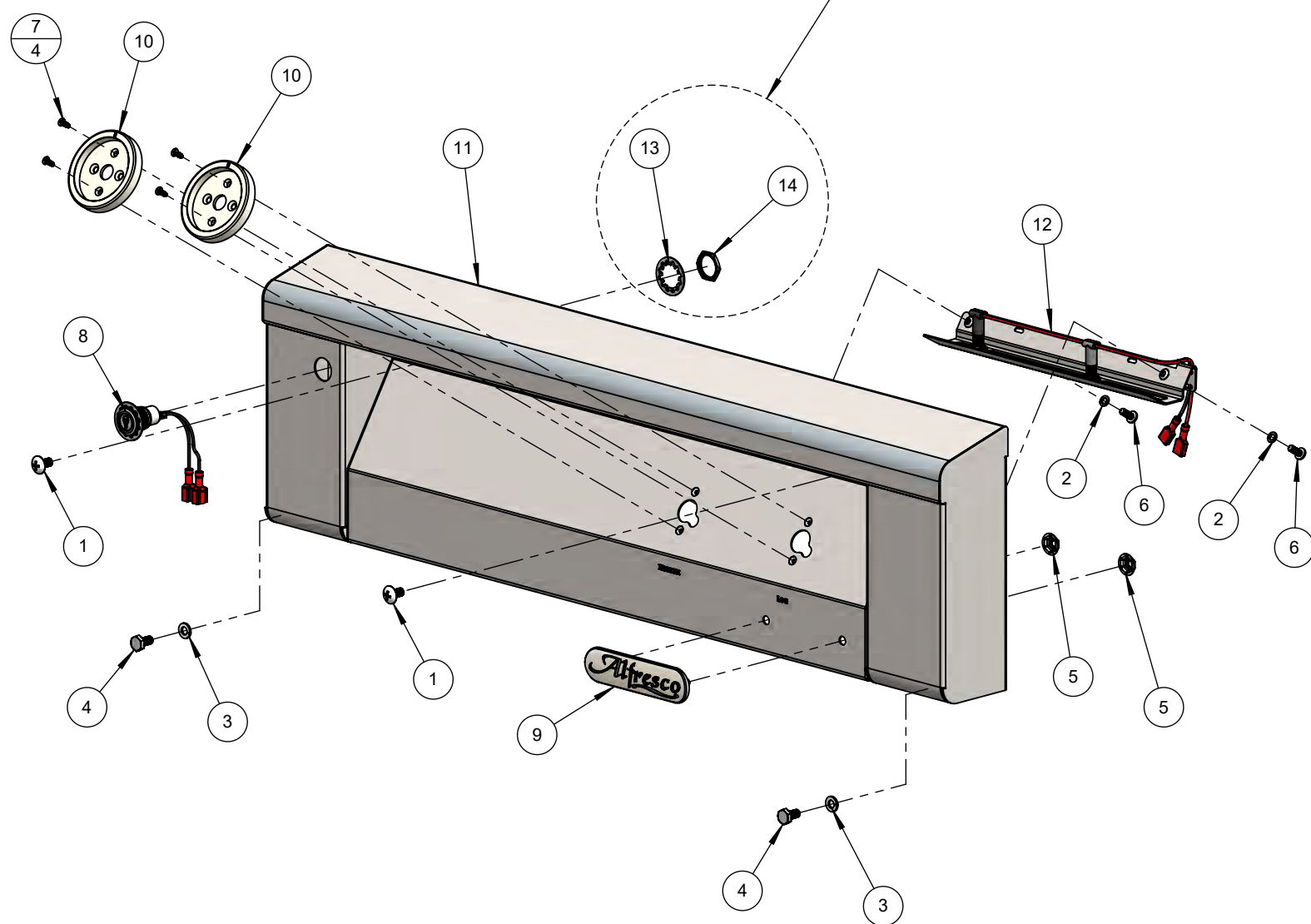

BILL OF MATERIAL

NO.	PART #	DESCRIPTION	QTY
1	100-2848	GLASS DOOR LATCH	1
2	200-0086	1/4-20 X 3/8 - TRUSS HEAD - PHILIPS SCREW	2
3	200-0088	WASHER - FLAT - 1/4" - NARROW - TYPE B	1
4	200-0112	SCREW 10-32 x 1/4 x 1/8 x 1/4- SHOULDER - 1/8 SOCKET - SS	2
5	200-0238	10-32 KEP NUT 18-8 STAINLESS	2
6	200-0267	10-32 X 1/2 - PAN HEAD - PHILLIPS SCREW	4
7	200-0376	WASHER - .391 Ø x .682 Ø (5/16"~3/8") -TRIPLE WAVE - SS	2
8	200-0394	SCREW SET - 10-32 x 1/4 - SS.SLDPRT	4
9	510-1049	GLASS DOOR KNOB ASSEMBLY	2
10	510-1103	LEFT GLASS DOOR ASSEMBLY	1
11	510-1104	RIGHT GLASS DOOR ASSEMBLY	1
12	510-1105	AXE-PZA LEFT DOOR - BODY HINGE	1
13	510-1106	AXE-PZA RIGHT DOOR - BODY HINGE	1

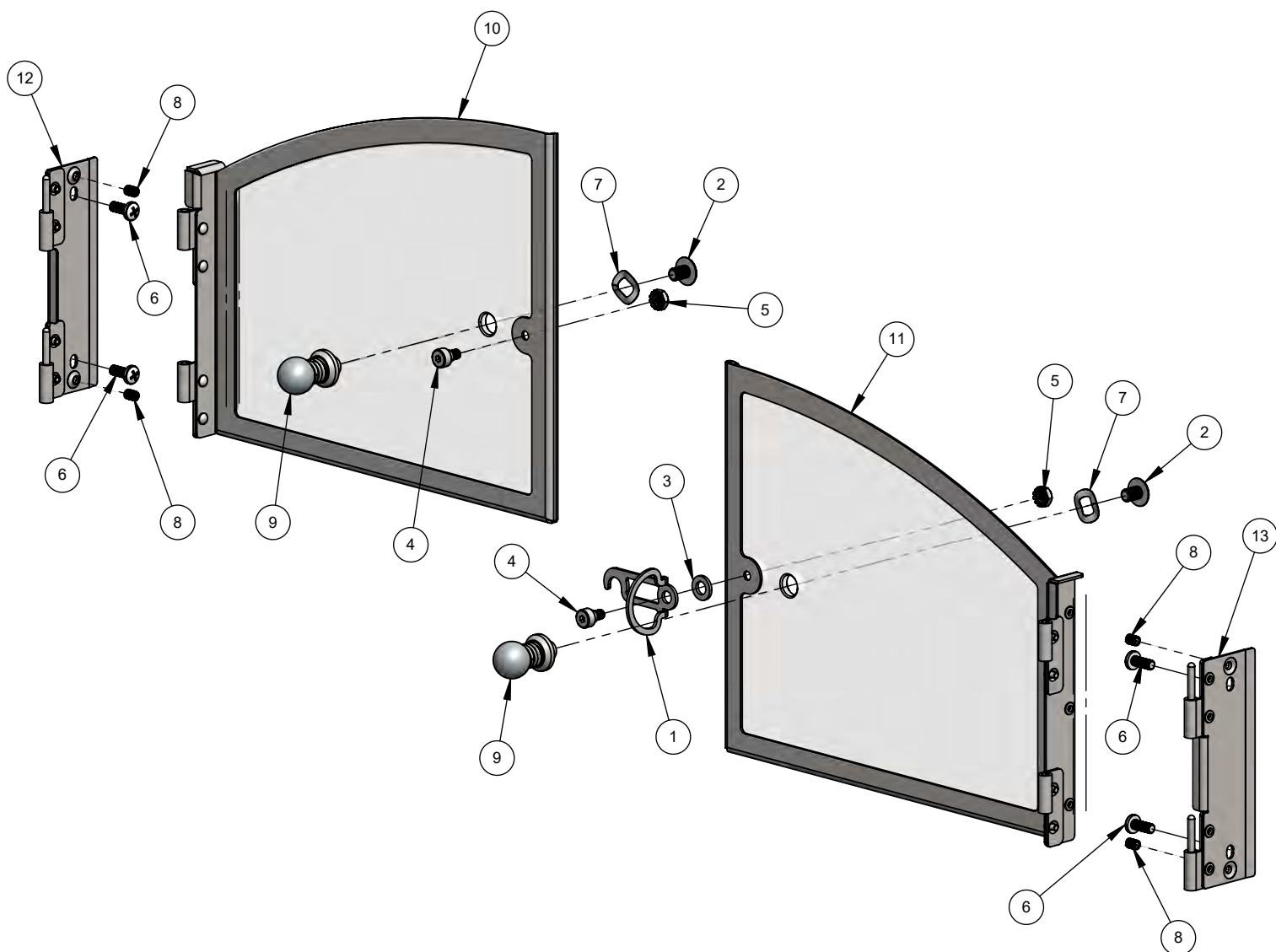

BILL OF MATERIAL

NO.	PART #	DESCRIPTION	QTY
1	100-2456	ALF-PZA LIGHT MOUNTING PLATE	1
2	100-2790	AXE-PZA ELECTRICAL BOX - INNER COVER	1
3	100-2791	AXE-PZA ELECTRICAL BOX - WEATHER COVER	1
4	100-2795	AXE-PZA SIDE HEAT SHIELD	2
5	100-2796	BOTTOM HEAT SHIELD	1
6	100-2798	FRONT PANEL SUPPORT BRACKET	1
7	100-2833	REGULATOR BRACKET	1
8	100-2844	LOG BURNER IGNITER SHIELD	1
9	100-2846	IR BURNER IGNITER BRACKET	1
10	100-2847	SAFETY VALVES BRACKET	1
11	200-0111	SCREW 8-18 X 1/2 - SELF TAP - 410 SS	57
12	220-0118	SCREW 10-32 x 1 1/4 - SS- PHILIPS	2
13	290-0362	LEVEL MOUNT 1/4-20 x 2 1/4	4
14	510-1090	AXE-PZA BURNER BOX - BOTTOM STRUCTURE	1
15	510-1098	AXE-PZA OVEN LINER	1
16	510-1099	AXE-PZA TOP SKIN ASSEMBLY	1

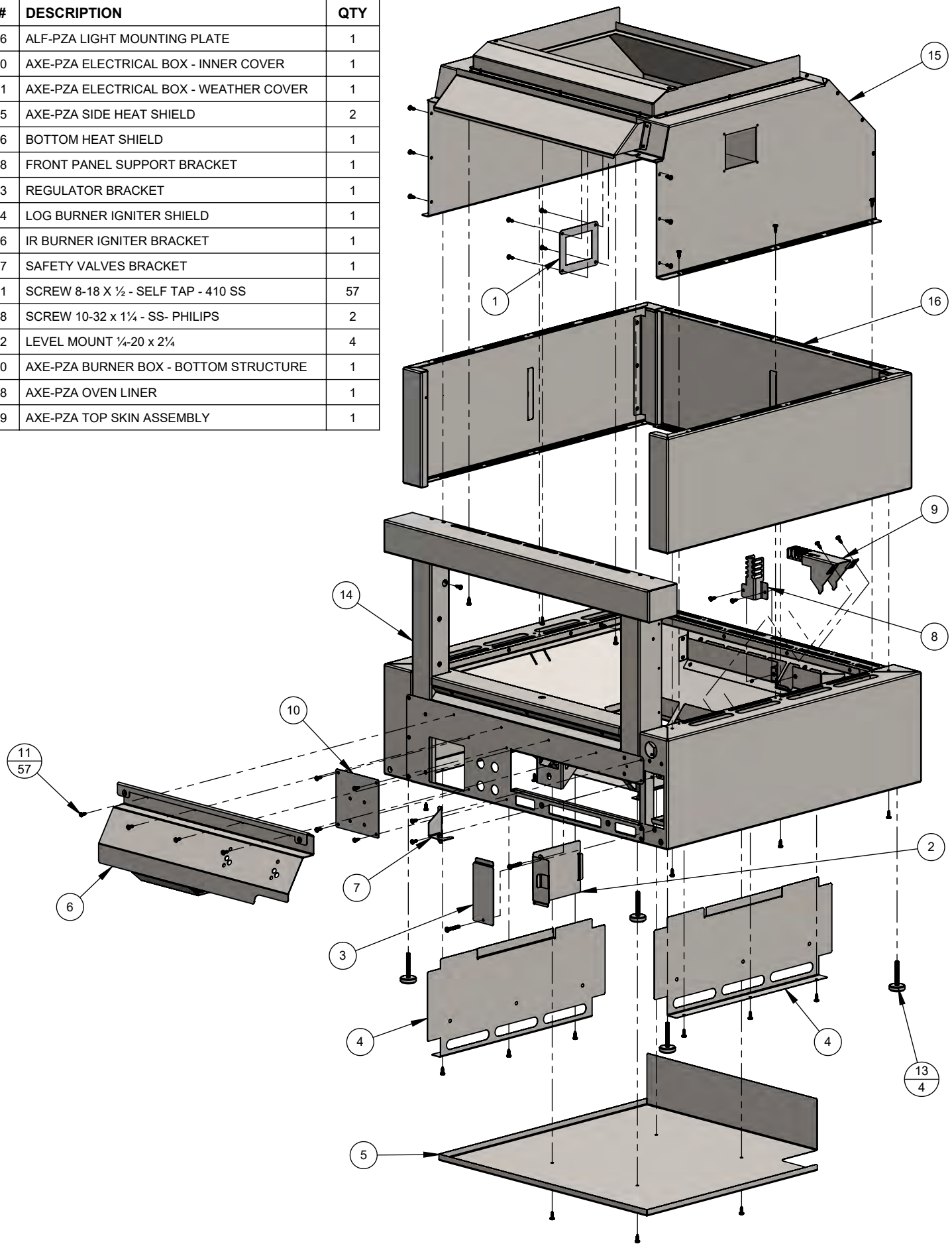

BILL OF MATERIAL

NO.	PART #	DESCRIPTION	QTY
1	100-2789	AXE-PZA ELECTRICAL BOX	1
2	200-0007	GROMMET 1/4" Ø - SRB RUBBER	2
3	200-0009	HEYCO STRESS RELIEF BUSHING # 1200 SR 6N3-4	2
4	200-0320	SCREW 8-32 x 3/8 - GROUNDING SCREW	1
5	210-0258	CABLE TIE - T&B L-5-50PM-9	4
6	210-0269	CABLE STRAIN RELIEF - HEYCO 1843	1
7	210-0488	LAMP FIXTURE ASSEMBLY - G9/120V/40W	1
8	210-0499	EXTENSION CORD - 8 FT. 18/3 - NEMA 5-15 - 90° PLUG	1
9	210-0584	SWITCH - LIGHT - LATCHING [ON/OFF]	1
10	210-0652	AXE-PZA ELECTRICAL WIRING HARNESS	1
11	210-0661	AMBER LED LIGHT - Ø 8 mm - WITH PINS	2
12	210-0666	PANEL LIGHT HARNESS	1
13	210-0690	HEARTH & LOG - HOT SURFACE IGNITER	2
14	220-0477	GAS VALVE - SINGLE PORT 5/16" Ø COMP W/ SWITCH	2
15	220-0483	SAFETY GAS VALVE	2

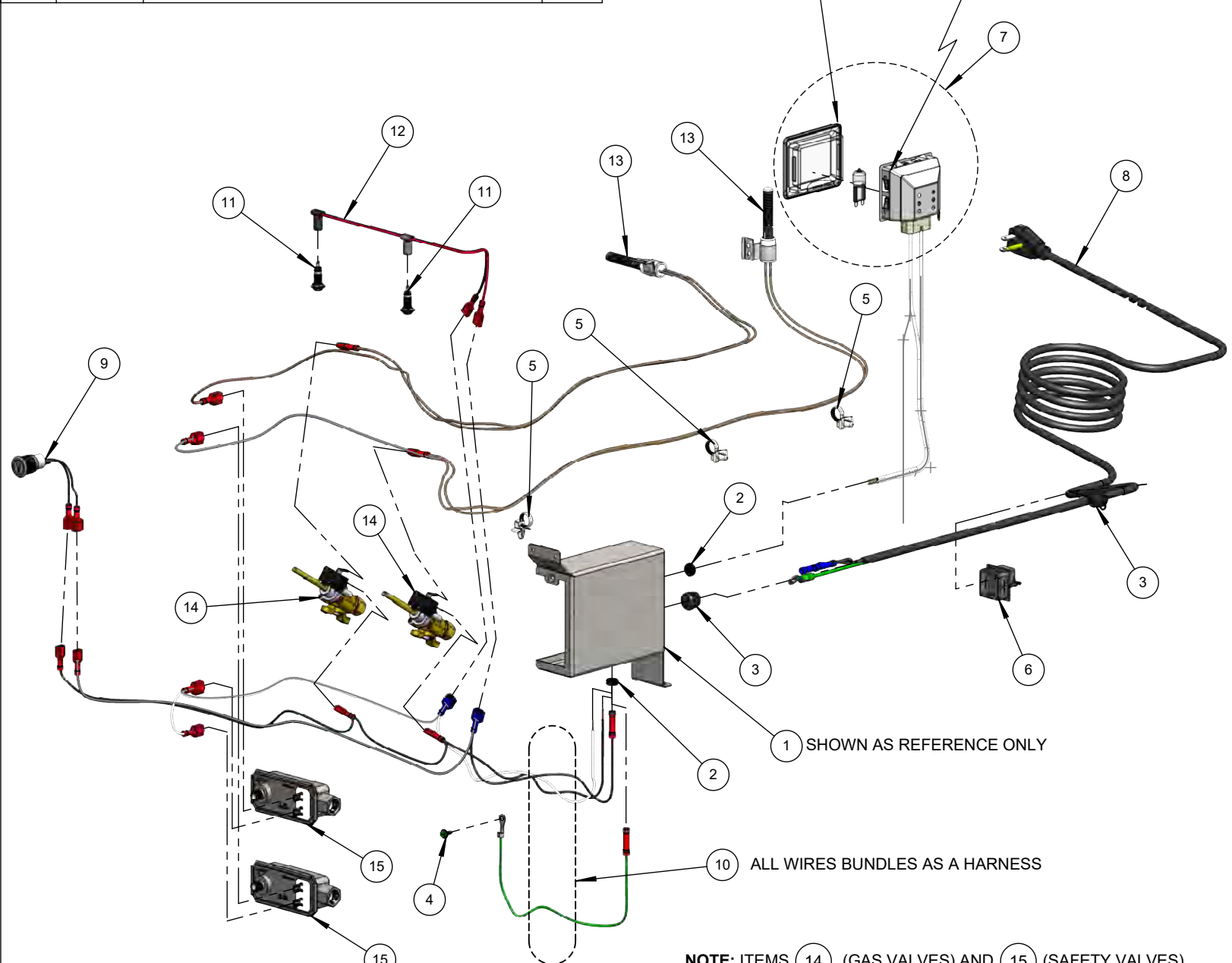
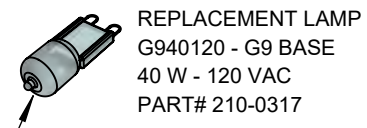
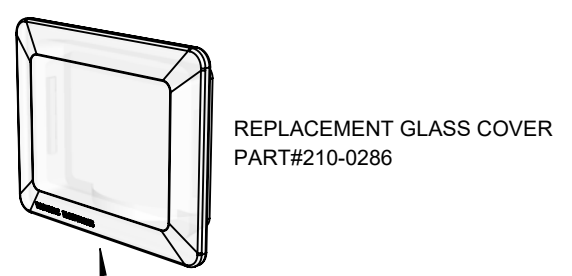

NOTE: ITEMS (14) (GAS VALVES) AND (15) (SAFETY VALVES)
SHOWN FOR CONNECTIONS REFERENCE ONLY - COMPONENTS
ARE PART OF PIPING ASSEMBLY DRAWING 510-1092 M1