

MCTRL R5

LED Display Controller



User Manual

Change History

Document Version	Release Date	Description
V1.0.3	2021-11-26	<ul style="list-style-type: none">• Optimized the document content.• Changed the document style.
V1.0.2	2019-09-06	Optimized the document content.
V1.0.1	2018-06-04	Updated the document style.
V1.0.0	2016-06-06	First release

AI'AN NOVASTAR TECH CO., LTD

Contents

1 Overview	1
1.1 Introduction.....	1
1.2 Features.....	1
2 Appearance	2
3 Applications	5
4 Cascade Devices.....	5
5 Home Screen	6
6 Menu Operations	7
6.1 Light a Screen Quickly.....	7
6.1.1 Step 1: Set Input Source.....	7
6.1.2 Step 2: Set Input Resolution	7
6.1.3 Step 3: Quickly Configure the Screen.....	9
6.2 Brightness Adjustment.....	9
6.3 Screen Settings	10
6.3.1 Quick Configuration.....	10
6.3.2 Advanced Configuration.....	10
6.3.3 Image Offset.....	10
6.4 Image Rotation.....	11
6.5 Display Control.....	11
6.6 Advanced Settings.....	12
6.6.1 Mapping Function	12
6.6.2 Load Cabinet Configuration Files	13
6.6.3 Set Alarm Thresholds	14
6.6.4 Save to RV Card.....	14
6.6.5 Redundancy Settings	14
6.6.6 Presettings.....	15
6.6.7 Input Backup.....	15
6.6.8 Factory Reset.....	15
6.6.9 OLED Brightness	15
6.6.10 HW Version.....	15
6.7 Communication Settings.....	15
6.8 Language.....	16
7 Operations on PC.....	17
7.1 Software Operations on PC	17
7.1.1 NovaLCT	17
7.1.2 SmartLCT.....	17
7.2 Firmware Update	18
7.2.1 NovaLCT.....	18
7.2.2 SmartLCT.....	18
8 Specifications	19

1 Overview

1.1 Introduction

The MCTRL R5 is the first LED display controller of NovaStar that supports image rotation. A single MCTRL R5 features a loading capacity of up to 3840×1080@60Hz. It supports any custom resolutions within this capacity, meeting the on-site configuration requirements of ultra-long or ultra-wide LED displays.

Working with the A8s or A10s Plus receiving card, the MCTRL R5 allows for free screen configuration and image rotation at any angle in SmartLCT, presenting a variety of images and bringing an amazing visual experience to users.

The MCTRL R5 is stable, reliable and powerful, dedicated to providing an ultimate visual experience. It can be mainly used in the rental and fixed installation applications, such as concerts, live events, security monitoring centers, Olympic Games and various sports centers.

1.2 Features

- A variety of input connectors
 - 1x 6G-SDI
 - 1 × HDMI 1.4
 - 1x DL-DVI
- 8x Gigabit Ethernet outputs and 2x optical outputs
- Image rotation at any angle
Work with the A8s or A10s Plus receiving card and SmartLCT to support image rotation at any angle.
- Support for 8-bit and 10-bit video sources
- Pixel level brightness and chroma calibration
Working with NovaLCT and NovaCLB, the receiving card supports brightness and chroma calibration on each LED, which can effectively remove color discrepancies and greatly improve LED display brightness and chroma consistency, allowing for better image quality.
- Firmware update via USB port on the front panel
- Up to 8 devices can be cascaded.

Table 1-1 Feature constraints

Feature	Constraints
Image rotation	<ul style="list-style-type: none"> ● A 10-bit input does not support image rotation. ● The screen must be configured on the MCTRL R5 before rotation setting in the LCD menu. ● The screen must be configured in SmartLCT before rotation setting in SmartLCT.

2 Appearance

Front Panel

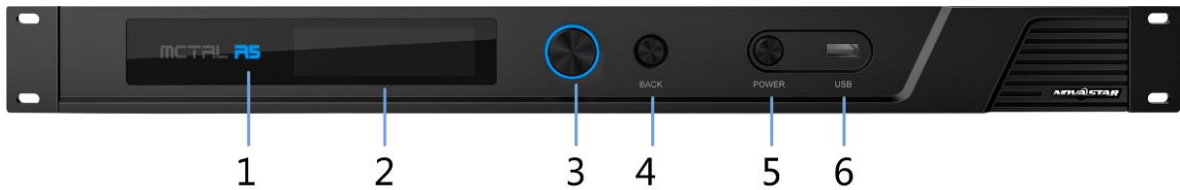

No.	Name	Description
1	"R5" indicator	Solid blue The device is functioning normally.
		Solid orange The device has no signal input.
		Breathing blue The device is in standby mode.
		Solid red The device has an alarm.
2	OLED screen	Display the device status, menus, submenus and messages.
3	Knob	On the home screen, press the knob to enter the main menu screen. On the main menu screen, rotate the knob to select a menu item or adjust the parameter value. Press the knob to confirm the operation.
4	BACK	Go back to the previous menu.
5	POWER	Standby button
6	USB	A USB port used to connect a USB drive for firmware update

Rear Panel



Connector Type	Connector Name	Description
Input	SDI	1x 6G-SDI input connector <ul style="list-style-type: none"> • Maximum resolution: 3840×1080@60Hz • Do NOT support interlaced signal input. • Do NOT support input resolution settings or input bit depth settings.
	HDMI	1x HDMI 1.4 input connector <ul style="list-style-type: none"> • Maximum resolution: 3840×1080@60Hz • Minimum resolution: 800×600@24Hz • Custom resolutions supported Maximum width: 3840 (3840×1080@60Hz) Maximum height: 3840 (800×3840@60Hz) • Supported standard resolutions: 1024×768@(24/25/30/48/50/60/72/75/85/100/120)Hz 1280×720@(24/25/30/48/50/60/72/75/85/100/120)Hz 1280×1024@(24/25/30/48/50/60/72/75/85/100/120)Hz 1366×768@(24/25/30/48/50/60/72/75/85/100/120)Hz

Connector Type	Connector Name	Description
		1440×900@(24/25/30/48/50/60/72/75/85/100/120)Hz 1536×1536@(24/25/30/48/50/60/72/75/85/100)Hz 1600×1200@(24/25/30/48/50/60/72/75/85/100/120)Hz 1920×1080@(24/25/30/48/50/60/72/75/85/100/120)Hz 1920×1200@(24/25/30/48/50/60/72/75/85/100)Hz 2048×640@(24/25/30/48/50/60/72/75/85/100/120)Hz 2048×1152@(24/25/30/48/50/60/72/75/85/100)Hz 2304×1152@(24/25/30/48/50/60/72/75/85/100)Hz 2560×816@(24/25/30/48/50/60/72/75/85/100/120)Hz 2560×1600@(24/25/30/48/50/60)Hz 3840×1080@(24/25/30/48/50/60)Hz <ul style="list-style-type: none"> • Support HDCP 1.4. • Do NOT support interlaced signal input.
	DVI	1x DL-DVI input connector <ul style="list-style-type: none"> • Maximum resolution: 3840×1080@60Hz • Minimum resolution: 800×600@24Hz • Custom resolutions supported Maximum width: 3840 (3840×1080@60Hz) Maximum height: 3840 (800×3840@60Hz) • Supported standard resolutions: 1024×768@(24/25/30/48/50/60/72/75/85/100/120)Hz 1280×720@(24/25/30/48/50/60/72/75/85/100/120)Hz 1280×1024@(24/25/30/48/50/60/72/75/85/100/120)Hz 1366×768@(24/25/30/48/50/60/72/75/85/100/120)Hz 1440×900@(24/25/30/48/50/60/72/75/85/100/120)Hz 1536×1536@(24/25/30/48/50/60/72/75/85/100)Hz 1600×1200@(24/25/30/48/50/60/72/75/85/100/120)Hz 1920×1080@(24/25/30/48/50/60/72/75/85/100/120)Hz 1920×1200@(24/25/30/48/50/60/72/75/85/100)Hz 2048×640@(24/25/30/48/50/60/72/75/85/100/120)Hz 2048×1152@(24/25/30/48/50/60/72/75/85/100)Hz 2304×1152@(24/25/30/48/50/60/72/75/85/100)Hz 2560×816@(24/25/30/48/50/60/72/75/85/100/120)Hz 2560×1600@(24/25/30/48/50/60)Hz 3840×1080@(24/25/30/48/50/60)Hz • Do NOT support interlaced signal input.
Output	1–8	8x RJ45 Gigabit Ethernet ports <ul style="list-style-type: none"> • Capacity per port up to 650,000 pixels (8bit) or 325,000 pixels (10bit) • Do not support audio output. • Support redundancy between Ethernet ports.
	OPT1–OPT2	2x 10G optical ports <ul style="list-style-type: none"> • OPT 1 copies and outputs the data on Ethernet ports 1–8. • OPT 2 is the copy channel of OPT 1.
Control	ETHERNET	Connect to the control computer.
	USB IN-OUT	<ul style="list-style-type: none"> • IN: 1x type-B USB 2.0, used as the input port to cascade devices or connect to PC for device debug

Connector Type	Connector Name	Description
		<ul style="list-style-type: none"> • OUT: 1x type-A USB 2.0, used as the output port to cascade devices. Up to 8 devices can be cascaded.
	GENLOCK IN-LOOP	<p>A pair of Genlock signal connectors. Support Bi-Level, Tri-Level and Black burst.</p> <ul style="list-style-type: none"> • IN: Accept the sync signal. • LOOP: Loop the sync signal.
Power	AC 100V~240V-50/60Hz	

NOVASTAR TECH CO., LTD

3 Applications

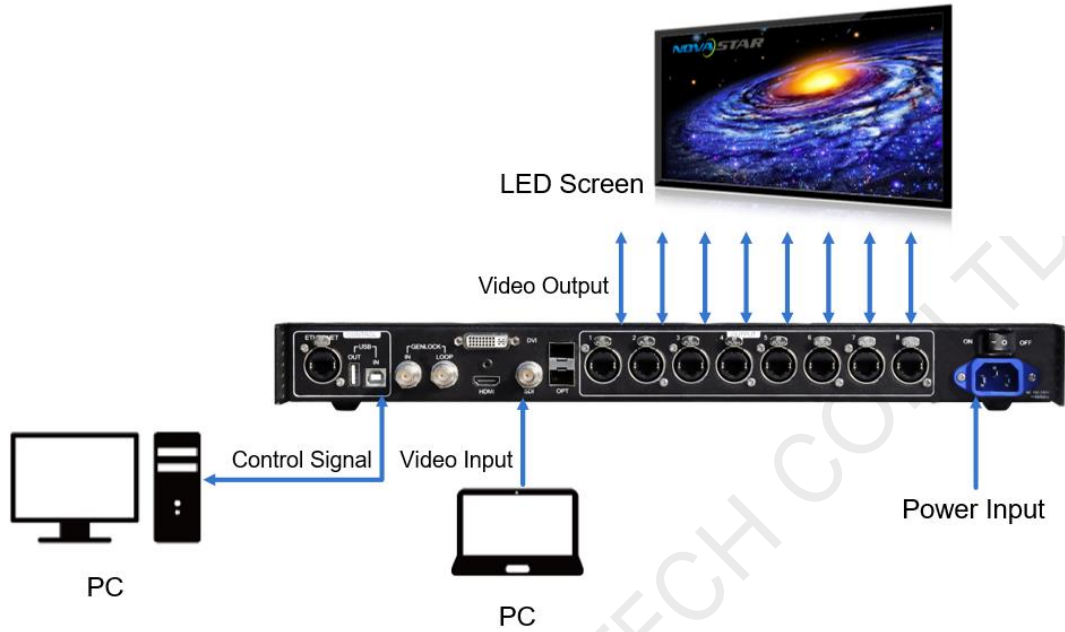

4 Cascade Devices



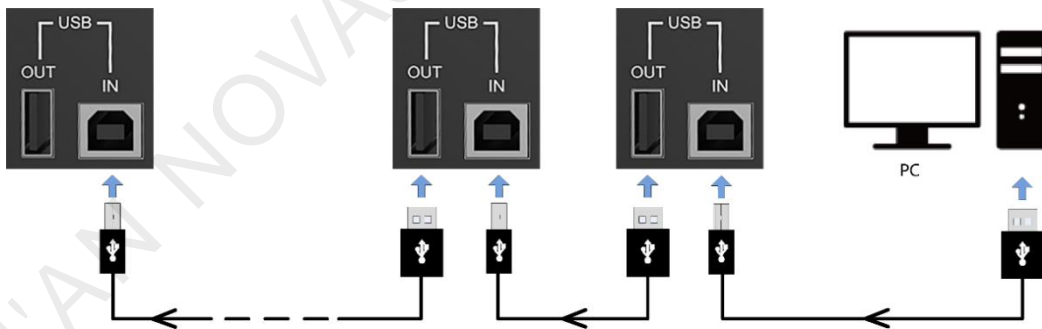



To control multiple MCTRL R5 devices simultaneously, follow the figure below to cascade them via the USB IN and USB OUT ports. Up to 8 devices can be cascaded.

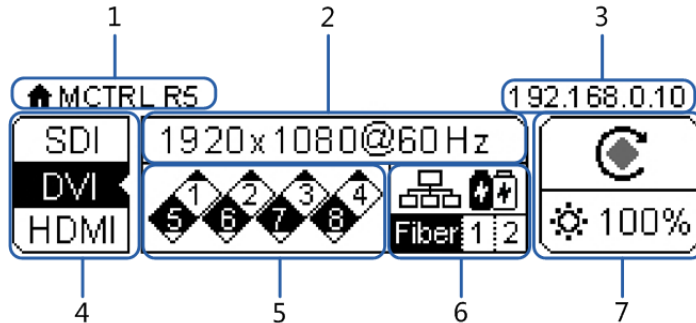

5 Home Screen

The figure below shows the home screen of the MCTRL R5.



No.	Description
1	The device name
2	The resolution and refresh rate of the current input source
3	IP Address
4	Types of input sources supported and their connection statuses
5	The working status of the Gigabit Ethernet ports <ul style="list-style-type: none"> • Black: The Ethernet port connection works and the port serves as master. • White: The Ethernet port is not connected or the connection does not work. • A mark in top corner of icon: The Ethernet port connection works and is in redundancy mode.
6/7	Working status description:
	 Normal voltage and temperature / voltage alarm / temperature alarm / temperature and voltage alarm
	 Optical port working status: <ul style="list-style-type: none"> • Black: The optical port connection works and the port serves as master. • White: The optical port is not connected or the connection does not work.
	 Connection status of control ports: USB connected / Ethernet connected / GENLOCK connected
	 Screen brightness
	 Image rotation enabled / disabled
	 Front panel buttons locked / unlocked Hold down the knob and BACK button simultaneously for 3s to lock or unlock all the front panel buttons. After the buttons are locked, all the button operations will not take effect and  appears on the OLED screen.

6 Menu Operations

The MCTRL R5 is powerful and easy to use. You can quickly configure the LED screen to light it up and display the entire input source following steps in 6.1 [Light a Screen Quickly](#). With other menu settings, you can further improve the LED screen display effect.

6.1 Light a Screen Quickly

Following the three steps below, namely Set Input Source > Set Input Resolution > Quickly Configure the Screen, you can quickly light up the LED screen to display the entire input source.

6.1.1 Step 1: Set Input Source

Supported input video sources include SDI, HDMI and DVI. Select an input source that matches the type of the inputted external video source.

Constraints:

- Only one input source can be selected at the same time.
- SDI video sources do not support the following functions:
 - Preset resolution
 - Custom resolution
- The 10-bit video sources are not supported when calibration function is enabled.

Figure 6-1 Input source

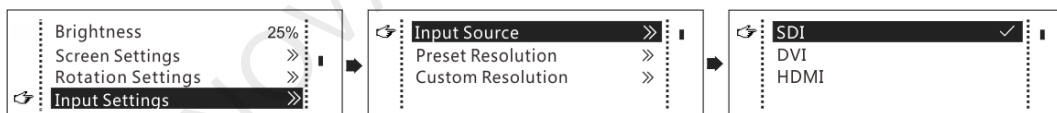

Step 1 On the home screen, press the knob to enter the main menu.

Step 2 Choose **Input Settings** > **Input Source** to enter its submenu.

Step 3 Select the target input source and press the knob to enable it.

6.1.2 Step 2: Set Input Resolution

Constraints: SDI input sources do not support input resolution settings.

The input resolution can be set through either of the following methods.

Method 1: Select a preset resolution

Select an appropriate preset resolution and refresh rate as the input resolution.

Figure 6-2 Preset resolution



- Step 1 On the home screen, press the knob to enter the main menu.
- Step 2 Choose **Input Settings** > **Preset Resolution** to enter its submenu.
- Step 3 Select a resolution and refresh rate, and press the knob to apply them.

Input Source	Available Standard Resolution Presets
HDMI 1.4 /DL-DVI	1024x768@(24/25/30/48/50/60/72/75/85/100/120)Hz
	1280x720@(24/25/30/48/50/60/72/75/85/100/120)Hz
	1280x1024@(24/25/30/48/50/60/72/75/85/100/120)Hz
	1366x768@(24/25/30/48/50/60/72/75/85/100/120)Hz
	1440x900@(24/25/30/48/50/60/72/75/85/100/120)Hz
	1536x1536@(24/25/30/48/50/60/72/75/85/100)Hz
	1600x1200@(24/25/30/48/50/60/72/75/85/100/120)Hz
	1920x1080@(24/25/30/48/50/60/72/75/85/100/120)Hz
	1920x1200@(24/25/30/48/50/60/72/75/85/100)Hz
	2048x640@(24/25/30/48/50/60/72/75/85/100/120)Hz
	2048x1152@(24/25/30/48/50/60/72/75/85/100)Hz
	2304x1152@(24/25/30/48/50/60/72/75/85/100)Hz
	2560x816@(24/25/30/48/50/60/72/75/85/100/120)Hz
	2560x1600@(24/25/30/48/50/60)Hz
	3840x1080@(24/25/30/48/50/60)Hz

Method 2: Customize a resolution

Customize a resolution by setting a custom width, height and refresh rate.

Figure 6-3 Custom resolution

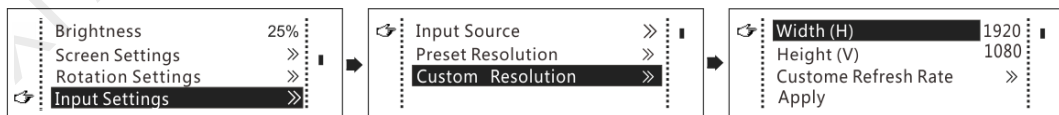

- Step 1 On the home screen, press the knob to enter the main menu.
- Step 2 Choose **Input Settings** > **Custom Resolution** to enter its submenu and set the screen width, height and refresh rate.
- Step 3 Select **Apply** and press the knob to apply the custom resolution.

6.1.3 Step 3: Quickly Configure the Screen

Follow the steps below to complete quick screen configuration.

Step 1 On the home screen, press the knob to enter the main menu.

Step 2 Choose **Screen Settings > Quick Config** to enter its submenu and set the parameters.

- Set **Cabinet Row Qty** and **Cabinet Column Qty** (numbers of cabinet rows and columns to be loaded) according to the actual situation of the screen.
- Set **Port1 Cabinet Qty** (number of cabinets loaded by Ethernet port 1). The device has restrictions on the number of cabinets loaded by the Ethernet ports. For details, see Note a).
- Set **Data Flow** of the screen. For details, see Note c), d), and e).

Note:	
a). If n ports are used to load the screen, the number of cabinets loaded by each of the first $(n-1)$ ports must be the same and the integral multiple of the number of cabinet rows or columns, and it must be greater than or equal to the number of cabinets loaded by the last port.	<p>Example:</p> <p>If all the 8 Ethernet ports are used to load the screen, the number of cabinets loaded by ports 1–7 must be the same and the integral multiple of the number of cabinet rows or columns. Therefore, you need to set only the number of cabinets loaded by port 1 according to the actual situation. The number of cabinets loaded by port 8 must be less than or equal to the number of cabinets loaded by port 1.</p>
b). For irregular screens, NovaLCT software must be connected to configure the screen.	
c). During data flow settings, you can rotate the knob to select a target data flow pattern.	
d). During data flow settings, ensure that the cabinets loaded by each Ethernet port are connected one by one in the same direction.	
e). During data flow settings, ensure that Ethernet port 1 is at the beginning position of the whole physical connection.	

6.2 Brightness Adjustment

Screen brightness allows you to adjust the LED screen brightness in an eye-friendly way according to the current ambient brightness. Besides, appropriate screen brightness can extend the service life of the LED screen.

Figure 6-4 Brightness adjustment

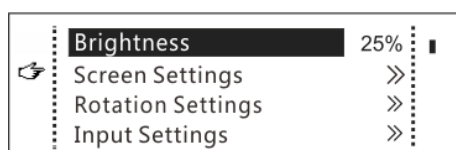

- Step 1 On the home screen, press the knob to enter the main menu.
- Step 2 Select **Brightness** and press the knob to confirm the selection.
- Step 3 Rotate the knob to adjust the brightness value. You can see the adjustment result on the LED screen in real time. Press the knob to apply the brightness you set when you are satisfied with it.

6.3 Screen Settings

Configure the LED screen to ensure the screen can display the entire input source normally.

Screen configuration methods include quick and advanced configurations. There are constrains on the two methods, explained as below.

- The two methods cannot be enabled at the same time.
- After the screen is configured in NovaLCT, do not use any of the two methods on the MCTRL R5 to configure the screen again.

6.3.1 Quick Configuration

Configure the whole LED screen uniformly and quickly. For details, see [6.1 Light a Screen Quickly](#).

6.3.2 Advanced Configuration

Set parameters for each Ethernet port, including number of cabinet rows and columns (**Cabinet Row Qty** and **Cabinet Column Qty**), horizontal offset (**Start X**), vertical offset (**Start Y**), and data flow.

Figure 6-5 Advanced configuration

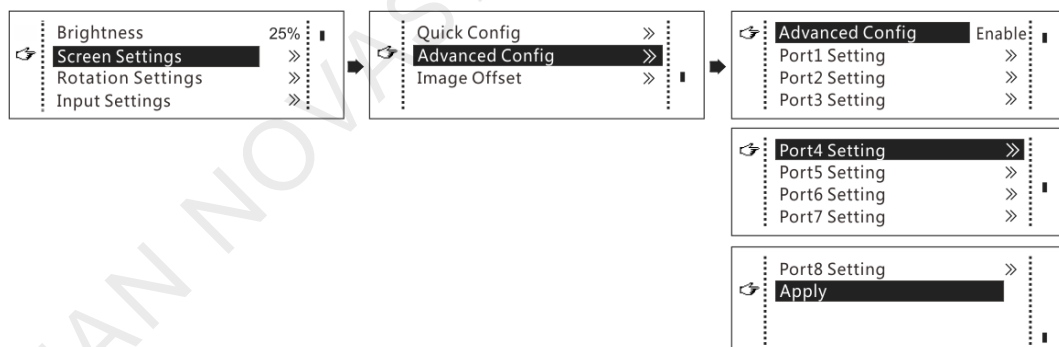

- Step 1 Choose **Screen Settings > Advanced Config** and press the knob.
- Step 2 In the caution dialog screen, select **Yes** to enter the advanced configuration screen.
- Step 3 Enable **Advance Config**, select an Ethernet port, set the parameters for it, and apply the settings.
- Step 4 Select the next Ethernet port to continue setting until all the Ethernet ports are set.

6.3.3 Image Offset

After configuring the screen, adjust the horizontal and vertical offsets (**Start X** and **Start Y**) of the overall display image to ensure it is displayed in the desired position.

Figure 6-6 Image offset



6.4 Image Rotation

There are 2 rotation methods: port rotation and screen rotation.

- Port rotation: Display rotation of cabinets loaded by Ethernet port (For example, set the rotation angle of port 1, and the display of cabinets loaded by port 1 will rotate according to the angle)
- Screen rotation: Rotation of the entire LED display according to the rotation angle

Figure 6-7 Image rotation

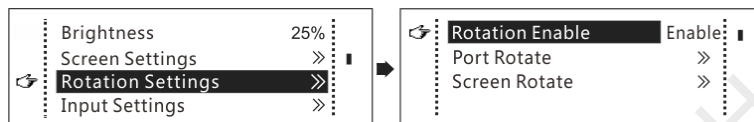

- Step 1 On the home screen, press the knob to enter the main menu.
- Step 2 Choose **Rotation Settings** > **Rotation Enable**, and choose **Enable**.
- Step 3 Choose **Port Rotate** or **Screen Rotate** and set the rotation step and angle.

Note

- The screen must be configured on the MCTRL R5 before rotation setting in the LCD menu.
- The screen must be configured in SmartLCT before rotation setting in SmartLCT.
- After screen configuration is done in SmartLCT, when you set rotation function on the MCTRL R5, a message saying "Reconfig screen, are you sure?" will appear. Please choose **Yes** and perform rotation settings.
- A 10-bit input does not support image rotation.
- The rotation function is disabled when the calibration function is enabled.

6.5 Display Control

Control the display status on the LED screen.

Figure 6-8 Display control

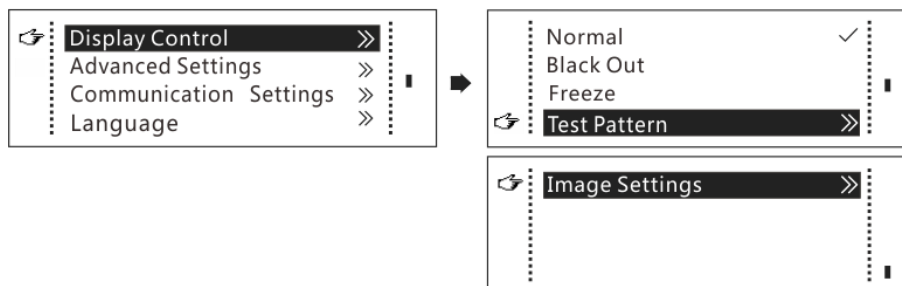

- Normal: Display the content of the current input source normally.
- Black Out: Make the LED screen go black and do not display the input source. The input source is still being played in the background.
- Freeze: Make the LED screen always display the frame when frozen. The input source is still being played in the background.
- Test Pattern: Test patterns are used to check the display effect and pixel operating status. There are 8 test patterns, including pure colors and line patterns.
- Image Settings: Adjust the color temperature, contrast, saturation and hue of the output image to improve the display effect.

Parameter	Description
Contrast	Range: 0% to 100%; stepping: 1%
Saturation	Range: 0% to 100%; stepping: 1%
Hue	Range: -180 to +180; stepping: 1

Note

The image settings function is disabled when the calibration function is enabled.

6.6 Advanced Settings

6.6.1 Mapping Function

When this function is enabled, each cabinet of the screen will display the sequence number of the cabinet and the Ethernet port that loads the cabinet.

Figure 6-9 Mapping function

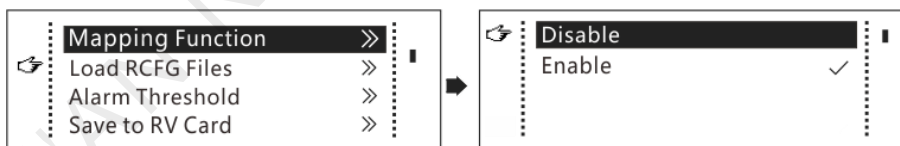



Example: "P:01" stands for the Ethernet port number and "#001" stands for the cabinet number.

Note

The receiving cards used in the system must support the Mapping function.

6.6.2 Load Cabinet Configuration Files

Before you begin: Save the cabinet configuration file (*.rcfgx or *.rcfg) to the local PC.

- Step 1 Run NovaLCT and choose **Tools > Controller Cabinet Configuration File Import**.
- Step 2 On the displayed page, select the currently used serial port or Ethernet port, click **Add Configuration File** to select and add a cabinet configuration file.
- Step 3 Click **Save the Change to HW** to save the change to the controller.

Figure 6-10 Importing configuration file of controller cabinet

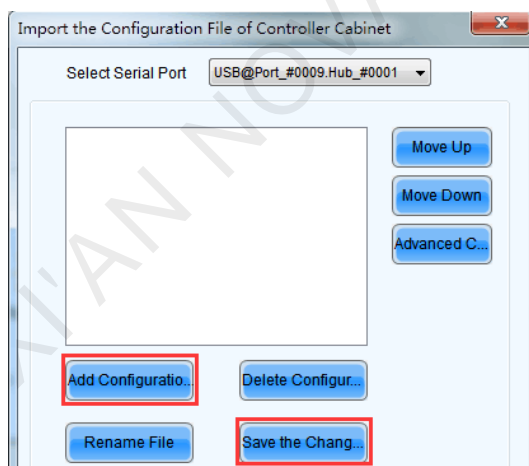

Note



Configuration files of irregular cabinets are not supported.

6.6.3 Set Alarm Thresholds

Set the alarm thresholds for device temperature and voltage. When a threshold is exceeded, its corresponding icon on the home screen will be flashing, instead of displaying the value.

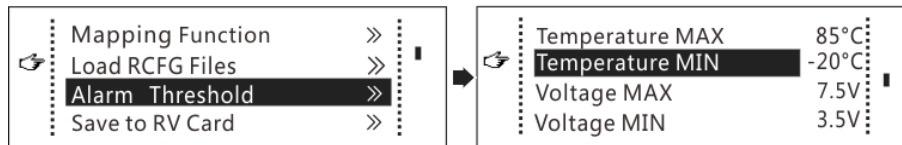
Figure 6-11 Setting alarm thresholds



- : Voltage alarm, icon flashing. Voltage threshold range: 3.5 V to 7.5 V
- : Temperature alarm, icon flashing. Temperature threshold range: -20°C to +85°C
- : Voltage and temperature alarms at the same time, icon flashing

Note

When there are no temperature or voltage alarms, the home screen will display the backup status.

6.6.4 Save to RV Card

By using this function, you can:

- Send and save the configuration information to the receiving cards, including brightness, color temperature, Gamma and display settings.
- Overwrite the information saved to the receiving card earlier.
- Ensure that the data saved in the receiving cards will not be lost upon power failure of receiving cards.

6.6.5 Redundancy Settings

Set the controller as the primary or backup device. When the controller works as a backup device, set the data flow direction as opposite to that of the primary device.

Figure 6-12 Redundancy settings

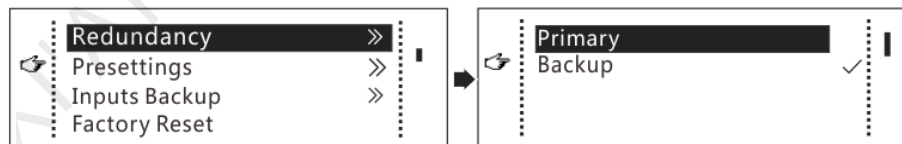

Note

If the controller is set as the backup device, when the primary device fails, the backup device will immediately take over the work of the primary device, that is, the backup takes effect. After the backup takes effect, the target Ethernet port icons on the home screen will have marks in top flashing once every 1 second.

6.6.6 Presettings

Choose **Advanced Settings > Presettings** to save current settings as a preset. Up to 10 presets can be saved.

- Save: Save current parameters as a preset.
- Load: Read back the parameters from a saved preset.
- Delete: Delete the parameters saved in a preset.

6.6.7 Input Backup

Set a backup video source for each primary video source. Other input video sources supported by the controller can be set as backup video sources.

After a backup video source takes effect, the video source selection is irreversible.

Primary Video source	Backup Video source
SDI	NULL/DVI/HDMI
DVI	NULL/SDI/HDMI
HDMI	NULL/DVI/SDI

6.6.8 Factory Reset

Reset the controller parameters to factory settings.

6.6.9 OLED Brightness

Adjust the brightness of the OLED menu screen on the front panel. The brightness range is 4 to 15.

6.6.10 HW Version

Check the hardware version of the controller. If a new version is released, you can connect the controller to a PC to update the firmware programs in NovalCT V5.2.0 or later.

6.7 Communication Settings

Set the communication mode and network parameters of the MCTRL R5.

Figure 6-13 Communication mode



- Communication mode: Include USB preferred and Local Area Network (LAN) preferred.

The controller connects to PC via USB port and Ethernet port. If **USB Preferred** is selected, the PC prefers to communicate with the controller via the USB port, or else via the Ethernet port.

Figure 6-14 Network settings

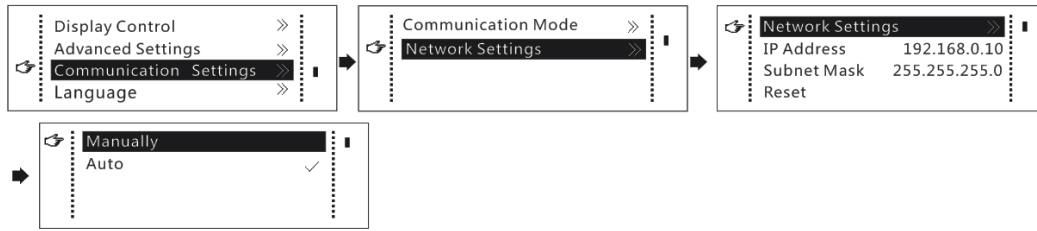

- The network settings can be done manually or automatically.
 - Manual setting parameters include controller IP address and subnet mask.
 - Automatic settings can read the network parameters automatically.
- Reset: Reset the parameters to defaults.

6.8 Language

Change the system language of the device.

7 Operations on PC

7.1 Software Operations on PC

7.1.1 NovaLCT

Connect the MCTRL R5 to the control computer installed with NovaLCT V5.2.0 or later via USB port to perform screen configuration, brightness adjustment, calibration, display control, monitoring, etc. For details on their operations, see *NovaLCT LED Configuration Tool for Synchronous Control System User Manual*.

Figure 7-1 NovaLCT UI

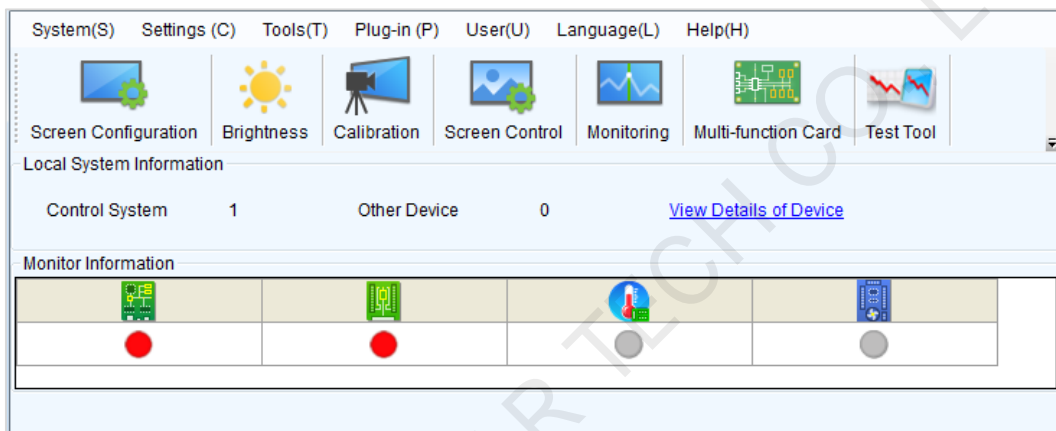

7.1.2 SmartLCT

Connect the MCTRL R5 to the control computer installed with SmartLCT V3.4.0 or later via USB port to perform building-block screen configuration, seam brightness adjustment, real-time monitoring, brightness adjustment, hot backup, etc. For details on their operations, see the SmartLCT user manual.

Figure 7-2 SmartLCT UI

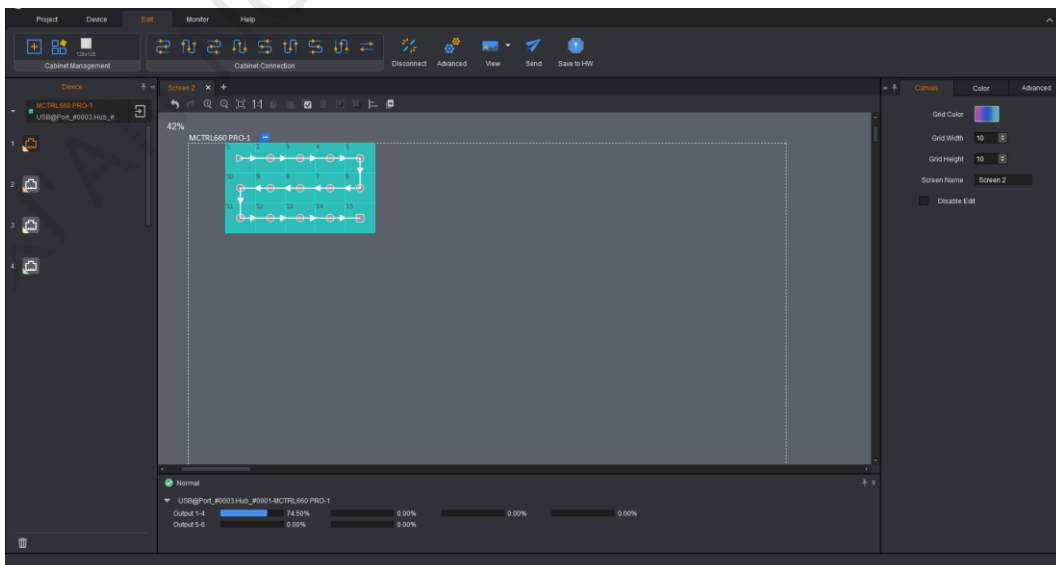

7.2 Firmware Update



7.2.1 NovaLCT

In NovaLCT, perform the following steps to update the firmware.

- Step 1 Run the NovaLCT. On the menu bar, go to **User > Advanced Synchronous System User Login**. Enter the password and click **Login**.
- Step 2 Type the secret code “**admin**” to open the program loading page.
- Step 3 Click **Browse**, select a program package, and click **Update**.

7.2.2 SmartLCT

In SmartLCT, perform the following steps to update the firmware.

- Step 1 Run SmartLCT and enter the V-Sender page.
- Step 2 In the properties area on the right, click  to enter the **Firmware Upgrade** page.
- Step 3 Click  to select the update program path.
- Step 4 Click **Update**.

8 Specifications

Electrical Specifications	Input voltage	AC 100V~240V-50/60Hz
	Rated power consumption	25 W
Operating Environment	Temperature	-20°C to +60°C
	Humidity	10% RH to 90% RH, non-condensing
Storage Environment	Temperature	-20°C to +70°C
	Humidity	10% RH to 90% RH, non-condensing
Physical Specifications	Dimensions	482.6 mm × 334.6 mm × 52.0 mm
	Weight	4.3 kg
Packing Information	Carrying case	530 mm × 370 mm × 140 mm
	Accessory box	405 mm × 290 mm × 48 mm 1x Power cord, 1x Ethernet cable, 1x USB cable, 1x HDMI cable, 1x DVI cable
	Packing box	550 mm × 400 mm × 175 mm

Copyright © 2021 Xi'an NovaStar Tech Co., Ltd. All Rights Reserved.

No part of this document may be copied, reproduced, extracted or transmitted in any form or by any means without the prior written consent of Xi'an NovaStar Tech Co., Ltd.

Trademark

NOVA STAR is a trademark of Xi'an NovaStar Tech Co., Ltd.

Statement

Thank you for choosing NovaStar's product. This document is intended to help you understand and use the product. For accuracy and reliability, NovaStar may make improvements and/or changes to this document at any time and without notice. If you experience any problems in use or have any suggestions, please contact us via the contact information given in this document. We will do our best to solve any issues, as well as evaluate and implement any suggestions.

XI'AN NOVASTAR TECH CO., LTD

Official website
www.novastar.tech

Technical support
support@novastar.tech