

GRAFIK Eye® 3000 Series Installer's Guide

Models 3100 and 3500



PLEASE LEAVE FOR OCCUPANT



Questions? Need technical assistance?

- In the U.S., Canada and the Caribbean: 1-800-523-9466
- In Mexico, Central and South America: 1-610-282-3800
- In Europe: 44-207-702-0657
- In the U.K.: 0800-282-107
- In France: 33-1-44-70-71-86
- In Germany: 49-309-710-4590
- In Japan: 03-5405-7333
- In Hong Kong: 2104-7733
- All others: 1-610-282-3800
- Website address: www.lutron.com
- E-mail: product@lutron.com

LIMITED WARRANTY

Lutron will, at its option, repair or replace any unit that is defective in materials or manufacture within one year after purchase. For warranty service, return unit to place of purchase or mail to Lutron at 7200 Suter Rd., Coopersburg, PA 18036-1299, postage pre-paid. **This warranty is in lieu of all other express warranties, and the implied warranty of merchantability is limited to one year from purchase. This warranty does not cover the cost of installation, removal or reinstallation, or damage resulting from misuse, abuse, or improper or incorrect repair, or damage from improper wiring or installation. This warranty does not cover incidental or consequential damages. Lutron's liability on any claim for damages arising out of or in connection with the manufacture, sale, installation, delivery, or use of the unit shall never exceed the purchase price of the unit.**

This warranty gives you specific legal rights, and you may also have other rights which vary from state to state. Some states do not allow limitations on how long an implied warranty lasts, so the above limitation may not apply to you. Some states do not allow the exclusion or limitation of incidental or consequential damages, so the above limitation or exclusion may not apply to you. This product may be covered by one or more of the following U.S. patents: 4,797,599; 4,803,380; 4,835,343; 4,893,062; 4,924,151; 5,038,081; 5,191,265; 5,430,356; 5,463,286; 5,530,322; 5,949,200; 5,990,635; 6,091,205; 6,380,692; DES 310,349; DES 311,170; DES 311,371; DES 311,382; DES 311,485; DES 311,678; DES 313,738; DES 317,593; DES 335,867; DES 344,264; DES 370,663; DES 378,814; D387,736; D412,315; D412,491; D422,567; D436,930; D453,742; D456,783; D461,782 and corresponding foreign patents. U.S. and foreign patents pending. Lutron, *GRAFIK Eye*, *Tu-Wire*, and *Hi-Lume* are registered trademarks; *Hi-Power 2•4•6*, *Eco-10*, *LIAISON*, and *Designer* are trademarks of Lutron Electronics Co., Inc. All other trademarks are the property of their respective owners.

© 2002 Lutron Electronics Co., Inc.



Safety standards listed above apply to one or more products in the *GRAFIK Eye* product line. Consult factory for specific information.

LUTRON

LUTRON-Quality Systems
Registered to ISO 9001

English

Español

Deutsch

Français

中文

Português

Nederlands

Italiano

STEP 1: Installing Control Units

This section shows how to install Control Units and make sure they are properly operating all connected loads.

Please read Appendix B: Special Mounting Considerations before installing!

⚠ DANGER! *GRAFIK Eye* lighting controls must be installed by a qualified electrician in accordance with all applicable regulations. Improper wiring can result in personal injury or damage to *GRAFIK Eye* lighting controls or other equipment. Always turn off circuit breaker/MCB or remove main fuse from power line before doing any work. To avoid overheating and possible damage to equipment, do not install dimming devices to dim receptacles, motor-operated appliances, or fluorescent lighting not equipped with *Lutron Hi-Lume*®, *Eco-10™*, or *Tu-Wire*® Electronic Dimming Ballasts. In dimmed magnetic low-voltage circuits, you can prevent transformer overheating and failure by avoiding excessively high current flow: Do not operate *GRAFIK Eye* lighting controls with any lamps removed or burned out; Replace any burned out lamps immediately; Use only transformers that incorporate thermal protection or fused primary windings. This lighting control is designed for residential and commercial use. *GRAFIK Eye* Controls are designed for indoor use only.

⚠ CAUTION! First test loads for short circuits.

1. Turn power OFF at the breaker/MCB panel or fuse box.
2. Connect standard light switch between live lead and the load wire to test circuit.
3. Turn power on and check for short or open circuits: If load does not operate, circuit is open. If the breaker/MCB trips (fuse blows or opens), circuit is shorted. Correct short or open circuits and test again.

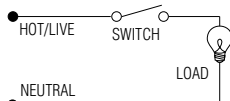

Load Types

The Control Units can control incandescent, halogen (tungsten), magnetic low-voltage, and neon/cold cathode load types. Electronic low-voltage and fluorescent load types can be controlled with an appropriate interface.

- All Electronic Low-Voltage (ELV) lighting used with the Electronic Low-Voltage Interface must be rated for **reverse phase-control dimming**. Before installing an ELV light source, verify with the manufacturer that their transformer can be dimmed. When dimming, an Electronic Low-Voltage Interface **MUST** be used with the Control Unit.
- Not all zones need to be connected; however, connected zones must have a load of at least 25W (40W for AU and CE models).
- No zone may be loaded with more than 800W (1200 for AU models).
- Unit must not carry more than 16A of total lighting load (10A for CE models).

Model

Number

Wallbox Size/Max. Unit Load

100-127V

230V

220-240V

3102/3502	2-Gang U.S./1200W/VA	4-Gang U.S.†/10A	2-Gang U.S./1600W/VA
3103/3503	3-Gang U.S./1500W/VA	4-Gang U.S.†/10A	3-Gang U.S./2400W/VA
3104/3504	4-Gang U.S./2000W/VA	4-Gang U.S.†/10A	4-Gang U.S.†/3000W/VA
3106/3506	4-Gang U.S./2000W/VA	4-Gang U.S.†/10A	4-Gang U.S.†/3000W/VA

† Lutron P/N 241-400 or 241-691 (old work metal wallbox).

Installation instructions. First, turn power off.

Preparation

1. **Mount Wallbox.** Use standard U.S. wallbox, 3 1/2 in. (87 mm) deep is strongly recommended, 2 3/4 in. (68 mm) deep minimum. Always allow at least 4 1/2 in. (110 mm) clearance above and below the faceplate to ensure proper heat dissipation.
2. **Pull Wires.** Use the rearmost knockouts when pulling wires into the wallbox. This will provide the most clearance when mounting the Control Unit.
3. **Remove Cover.** Remove the Control Unit's cover and hinged faceplate by pulling outward at each corner.

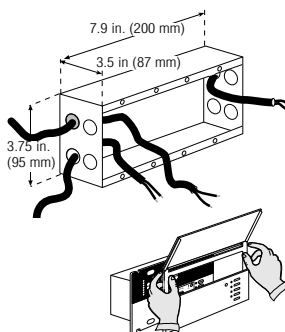

Line Voltage/Mains Wiring

Important Wiring Notes!

- Use properly certified cable for all line voltage/mains cables and Class 2/PELV cables.
- In Europe, acceptable types of cable include HAR certified cable with insulated cores enclosed in a sheath. This cable must bear the appropriate certification mark pertaining to national wiring rules for fixed installations. If certified cable with insulated cores enclosed in a sheath is used for the Power cables, the Class 2/PELV wiring can be any of the specified cables in **Appendix A: More about Class 2/PELV Wiring.**
- Proper short-circuit and overload protection must be provided at the distribution panel. You can use up to a 20A (16A for AU, and 10A for CE models) maximum circuit breaker/MCB or equivalent (tripping curve C according to IEC60898/EN60898 is recommended) with adequate short-circuit breaking capacity for your installation.
- Install in accordance with all local and national electrical codes.
- **CAUTION!** Do not connect line voltage/mains cable to Class 2/PELV terminals.
- Earth/Ground terminal connection must be made as shown in wiring diagrams.
- Do not mix different load types on the same zone!
- Fluorescent and electronic low voltage loads require interfaces. Zone loads that exceed 800W/VA (1200W/VA for AU models) and total unit loads that exceed the unit capacity require power boosters.

Wire the Control Unit

1. Strip 1/2 in. (12 mm) insulation from all wires in wallbox and connect them to appropriate terminals on the back of the Control Units. The recommended installation torque is 9.0 in.-lbs. (1.0 N•m) for line voltage connections and 10 in.-lbs. (1.3 N•m) for the earth/ground connection. Each power terminal can accept up to two #12 AWG (2.5 mm²) wires (does not apply to Class 2/PELV terminal block).

GRX-3106/3506*, GRX-3106-AU/3506-AU*

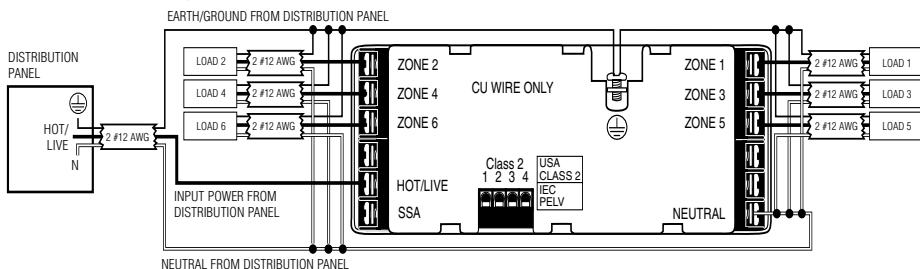

GRX-CE Models*

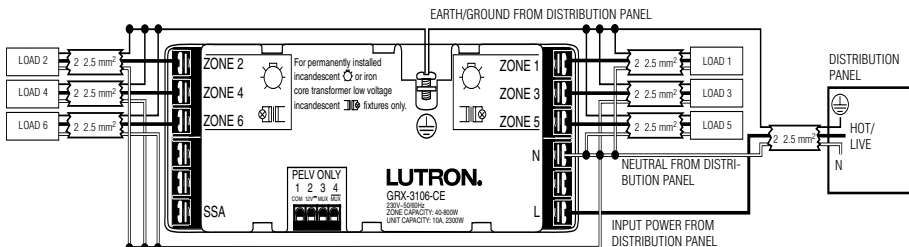

* For phase-to-phase and delta-feed wiring, please contact Lutron.

Class 2/PELV Wiring

Connect Class 2/PELV wiring *only* if your project has Wallstations and/or more than one Control Unit.

Use recommended cable as specified in **Appendix A: More About Class 2/PELV Wiring**.

Use the rearmost knockouts when pulling wires into the wallbox. This will provide the most clearance when mounting the Control Unit.

- Strip 1 in. (25 mm) of insulation from the Class 2/PELV cable.
- Strip 3/8 in. (8 mm) of insulation from each wire.
- Connect the Class 2/PELV wires to the Class 2/PELV terminal block.** Make sure no bare wire is exposed after making connections. The recommended installation torque is 3.5 in.-lbs. (0.4 N•m) for Class 2/PELV connections.
- The Class 2/PELV cable and terminal block should be separated from line voltage/mains cables by at least 1/4 in. (7 mm).

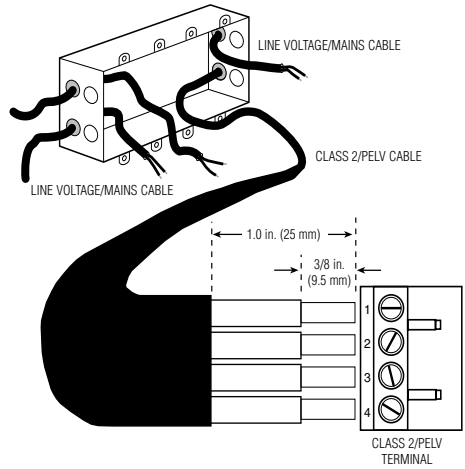

Mounting

- Mount as shown using the four screws provided. (When mounted in the wallbox, the Class 2/PELV cable and terminal block should remain separated from the line voltage/mains cables.)
- Reattach the faceplate to the Control Unit by pushing inward at each corner.

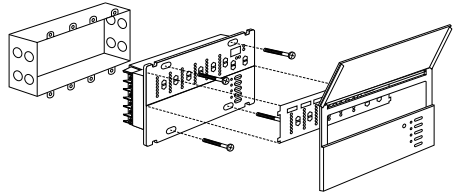

Testing: Do the lights work?

- Restore Power.
- Press **Scene 1 button** on front of the *GRAFIK Eye* Control Unit. The Scene 1 LED will light.
- Press **zone ▲ or ▼** to raise or lower the light levels. Make sure that the Control Unit is dimming all connected loads. Refer to **Appendix C: Troubleshooting**, or call *Lutron*.

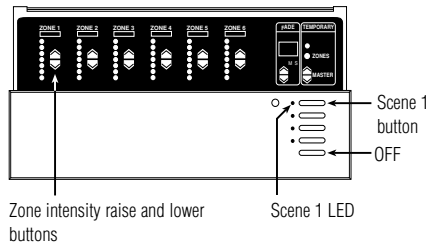

STEP 2: Setting Up *GRAFIK Eye* Control Units

GRAFIK Eye Control Unit

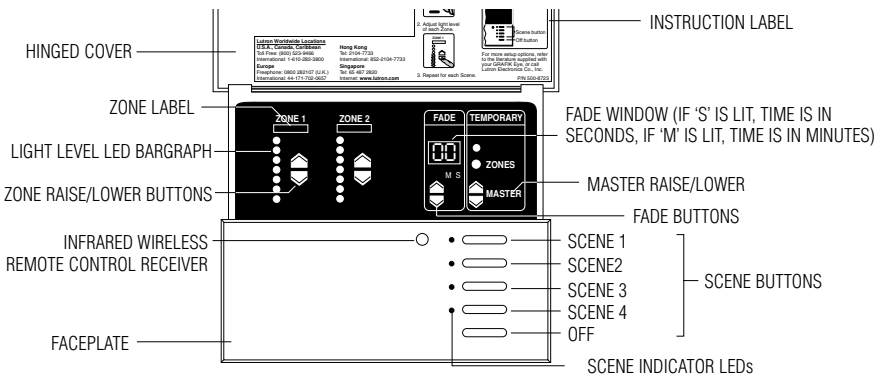

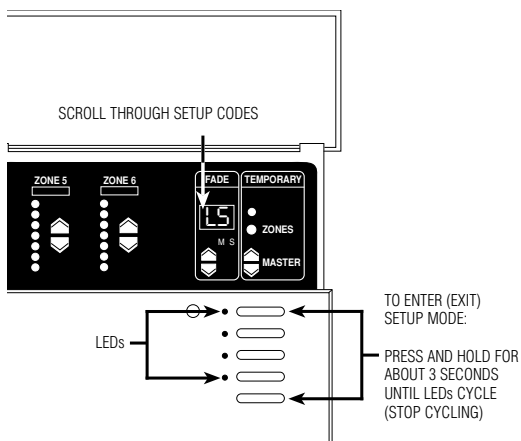

This section shows how to set up a *GRAFIK Eye* Control Unit, including:

- Identifying the load type for each zone of lighting connected to the Control Unit.
- Setting up the scenes to create the desired lighting effects, and make sure the Control Unit is working correctly.

To set up the *GRAFIK Eye* Control Unit, enter the “setup mode” and use the menu of setup codes that appear in the FADE window. Step-by-step instructions for using the setup codes are on the following pages.

How to Enter and Exit Setup Mode

To enter setup mode: Press and hold the Scene 1 and OFF button for about three seconds, until the scene LEDs start cycling.

To exit setup mode: Exit setup mode the same way you entered it. Press and hold the Scene 1 and OFF button for about 3 seconds, until scene LEDs stop cycling. The Control Unit is out of setup mode; back in normal operating mode.

In setup mode, the FADE window displays the setup codes. To scroll through the menu of setup codes, press the FADE ▲ or ▼ buttons.

The following is a list of the setup codes and their descriptions:

Code	Stands for	Description
Sd	Save Options	Select from several save options (Pg. 8)
Sc	Scene	Set unaffected zones and set any of the 16 scenes (Pg. 8)
A-	Address	Identify Control Units when setting up system communications (Pg. 9)
LS*	Load Select	Identify load type (Pg. 5)
LE	Low End	Set low end trim (Pg. 7)

* When you enter setup mode, this code appears first.

- If you press FADE ▲, you will see **A-**, **Sc**, then **Sd**.
- If you press FADE ▼, you will see **LE**.

Identifying the Load Type for each Zone

Lutron ships *GRAFIK Eye* Control Units with all zones set for incandescent/halogen (tungsten) lighting. If your project has non-incandescent loads, change all non-incandescent zones to the correct load type.

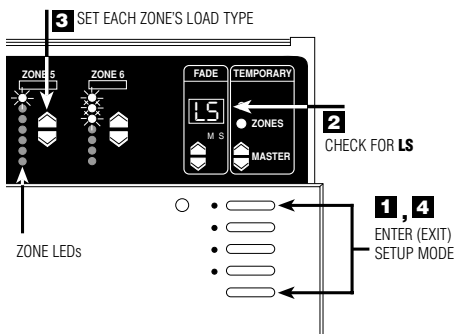

- 1. Enter setup mode.** Press and hold Scene 1 and OFF buttons for about 3 seconds, until scene LEDs cycle.
- 2. Check for LS in FADE window.** (LS is the first code to appear when you enter setup mode. For the LS mode, ZONE LEDs turn on from top to bottom.)
- 3. Set each zone's load type.** Press ZONE ▲ and ▼ until ZONE LEDs match the load type connected to each zone. Refer to chart on next page.
- 4. Exit setup mode.** Press and hold Scene 1 and OFF buttons for about 3 seconds, until scene LEDs stop cycling.

In the 6-Zone Control Unit shown here:

- Zone 5 is set for incandescent or magnetic low-voltage.
- Zone 6 is set for neon/cold cathode.

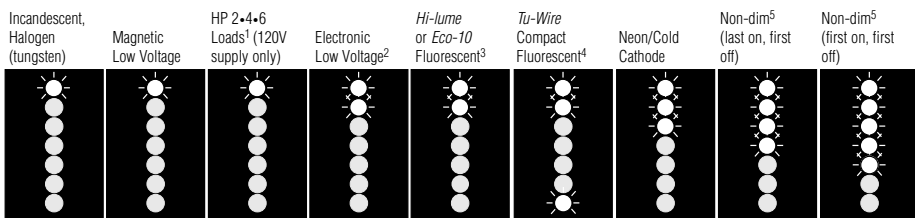

1. Set all zones connected to HP Dimming Modules as shown—no matter what load type they are (including non-dim or switching). The HP can be used to switch non-capacitive ballasts. To fine-tune the dimming of these “HP-powered” zones, you must adjust high- and low-end trim on the HPs as described in the Instruction Sheet supplied with the unit. Do **NOT** use HPs with generator-supplied line/mains voltage.
2. All electronic low-voltage (ELV) lighting used with the Electronic Low-Voltage Interface (ELVI) must be rated for reverse phase control dimming. Before installing an ELV light source, verify with the manufacturer that their transformer can be dimmed. When dimming, an ELVI **MUST** be used with the 3000 Series Control Unit.
3. Any zones set for Lutron *Hi-lume* or *Eco-10* fluorescent lighting **must** have GRX-FDBI or GRX-TVI Fluorescent Interfaces. Consult Lutron for more information.
4. Please note that the *Tu-Wire* Compact Fluorescent, unlike other fluorescent load types, **does not** require an FDBI interface. This load type is not available in GRX-CE models.
5. Use non-dim for any lights to be switched on and off only—not dimmed (unless using HP Dimming Module).
 - Fluorescent non-dim loads with electronic or magnetic ballasts must: use a GRX-TVI Interface *and* be set for non-dim mode, or use an *HP 2•4•6* Dimming Module *and* be set for *HP 2•4•6* Dimming Module loads.

What is a Scene?

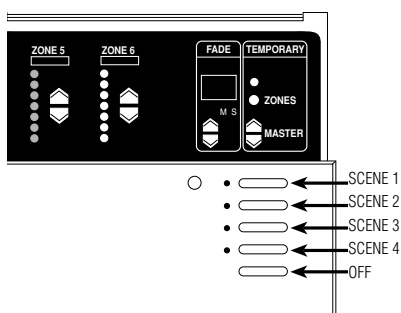

Scenes are the preset light levels and fade times stored in the Control Unit. To create a scene, set the appropriate intensity for each ZONE. To recall a scene, simply press one of the buttons. The first button calls up Scene 1; the second, Scene 2; and so on. The last button turns lights Off.

For example, typical scene settings for a living room might be:

Scenes 1—4 can be selected on the Control Unit. However, all Control Units are capable of storing up to 16 scenes. Scenes 5 through 16 can be selected using Wallstations.

How to Set up Lighting Scenes

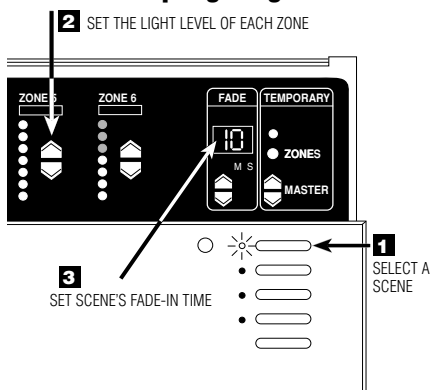

Note: Control Unit must be in **Sd** mode. See Page 8 for more information regarding Save Options.

To set up scenes 1 through 4:

1. **Select a scene.** Press the Scene button for the scene you want to adjust. (First button for Scene 1, second button for Scene 2, and so on.) Note that the last button is the “Off” Scene. You do not set intensities for this button.
2. **Set each zone’s light levels.** Press ZONE ▲ and ▼ to adjust each ZONE to the right visual intensity for this scene. To program scenes 5 through 16, or for more precise zone intensity adjustment with a *GRAFIK Eye 3500* Control Unit, refer to page 7.
3. **Set scene’s FADE-in time.** Press FADE ▲ and ▼ to make FADE-in time anything from 0—59 seconds or 1—60 minutes*. (FADE-in time is how long it takes the lights to adjust to the new levels when the scene is selected.)

* The S and M indicators under the FADE window show whether FADE is “M”inutes or “S”econds. To set FADE in minutes, you press FADE ▲ to scroll through 1—59 seconds . . . the M lights. FADE is now expressed in minutes. To get back to seconds, press FADE ▼ until the window shows “S”econds. The FADE-in time from OFF to any Scene is factory-set at 3 seconds.

Repeat this process to set up each of the remaining scenes. Note that you can also set up a “FADE-to-off” time. Press the OFF button and adjust FADE as desired.

How to Adjust Light Levels Temporarily

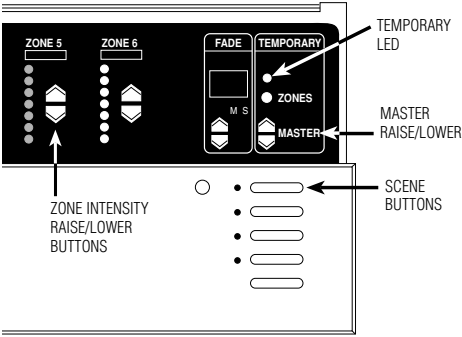

Control Unit must be in either **Sd** or **Sb** mode. See Page 8 for more information regarding Save Options.

To adjust an entire scene:

Press the appropriate scene button.

Press MASTER ▲ or ▼ to raise or lower the intensity of all zones.

To adjust a zone:

If the TEMPORARY LED is not already lit, press the TEMPORARY ZONES button. The TEMPORARY LED above the TEMPORARY ZONES button will light.

Press ZONE ▲ or ▼ to adjust any zone's intensity.

Note: These adjustments are temporary and remain only until a new scene selection occurs.

How to Set Low-end Trim—OPTIONAL

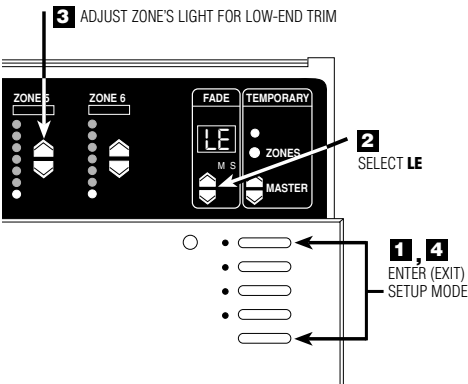

If necessary, adjust the low-end trim to achieve uniform low-intensity dimming and to eliminate flicker (especially with neon/cold-cathode and fluorescent loads).

- 1. Enter setup mode.** Press and hold Scene 1 and OFF buttons for about 3 seconds, until scene LEDs start cycling.
- 2. Select LE (low end)** by pressing FADE ▼ once. All zones go to their lowest possible dim levels and only their bottom LED is lit*.
- 3. Adjust zone's lights for low-end trim.** Use ZONE ▼ and ▲ to dim the zone's lights as much as possible without causing flicker. Repeat this process for any other zones that require low-end trim.
- 4. Exit setup mode.** Press and hold Scene 1 and OFF buttons until scene LEDs stop cycling.

Note: The ZONE LED bargraph does not change while you make low-end trim adjustments. The bargraph remains set to its lowest level in this mode.

* Except zones set for non-dim. For these, all zone LEDs are lit, and you cannot adjust the low-end trim.

Advanced Scene Programming Options—OPTIONAL

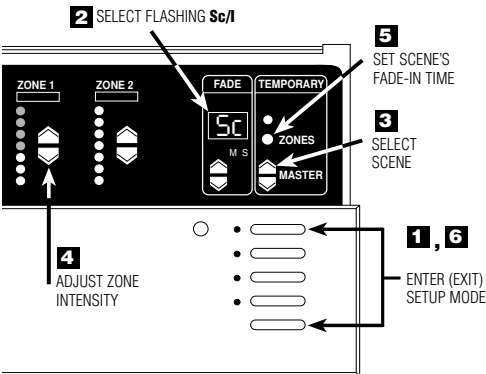

Programming Scenes 5 through 16.

- 1. Enter setup mode.** Press and hold Scene 1 and OFF buttons about 3 seconds until scene LEDs start cycling.
- 2. Select Sc** (the code for scene setup) by pressing FADE ▲ twice. **Sc** and **1** (Scene 1) will alternately flash in the FADE window.
- 3. Select scene.** Press MASTER ▲ or ▼ to select the scene to be programmed.
- 4. Adjust ZONE-intensity.** Press ZONE ▲ or ▼ to adjust zone's intensity (GRX-3500 units will display exact percentage light output — press again to adjust light levels in 1% increments).
- 5. Set scene's FADE-in time.** Press and hold the TEMPORARY ZONES button. The current FADE-in time is displayed. Adjust using the FADE ▲ and ▼ while still holding the TEMPORARY ZONES button.
- 6. Exit setup mode.** Press and hold Scene 1 and OFF buttons until LEDs stop cycling.

How to Set an “unaffected zone” — OPTIONAL

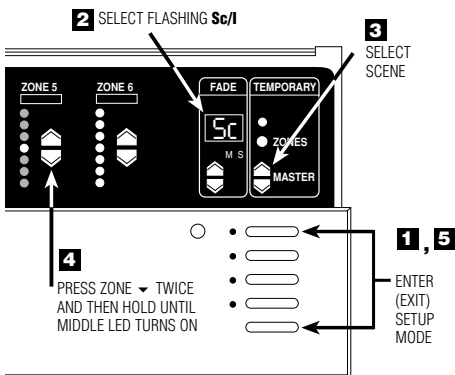

You can set up a zone to be “unaffected” when a certain scene is selected. (The unaffected zone’s light levels remain unchanged when the new specified scene is selected.)

- 1. Enter setup mode.** Press and hold Scene 1 and OFF buttons about 3 seconds until scene LEDs start cycling.
- 2. Select Sc** (the code for scene setup) by pressing FADE ▲ twice. Sc and I (for scene 1) will alternately flash in the FADE window.
- 3. Select scene.** Press MASTER ▲ and ▼ to select the scene that will have the unaffected zone.
- 4. Program any ZONE as unaffected.** Press ZONE ▼ twice and then hold until all the bargraph LEDs go out and the middle LED light. (It may take up to 10 seconds after the last LED goes out until the middle LED lights.) This zone’s light levels will no longer be affected when this scene is selected. Note that you can set up several zones to be unaffected in a scene.
- 5. Exit setup mode.** Press and hold Scene 1 and OFF buttons until LEDs stop cycling.

How to Set Save Options — OPTIONAL

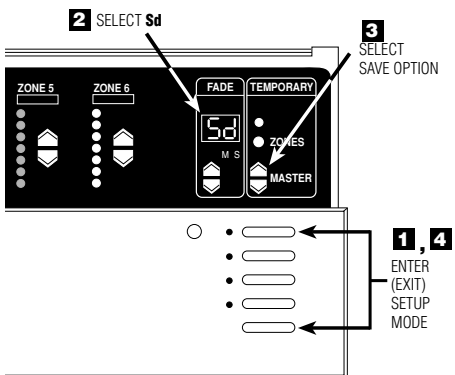

The *GRAFIK Eye 3000 Series Control Units* allow selection of several different Save Options. Follow these steps to access the Save Options.

- 1. Enter setup mode.** Press and hold Scene 1 and OFF buttons for about 3 seconds until scene LEDs start cycling.
 - 2. Select Sd.** Press FADE ▲ until Sd is displayed in the FADE window.
 - 3. Select Save Options.** Press MASTER ▲ and ▼ to select between the Save Options:
 - Sd Save by Default.** Changing a zone’s intensity level or fade time permanently changes the preset scene. To temporarily change a light level, see “How to adjust light levels temporarily” on Page 7.
 - Sb Save by Button.** TEMPORARY ZONES LED is normally ON and all intensity and fade changes are temporary unless the TEMPORARY ZONES LED is turned OFF with the TEMPORARY ZONES button.
 - Sn Save Never.** TEMPORARY ZONES LED is permanently ON and cannot be turned OFF. In this mode, all intensity changes are temporary.
 - 4S Four Scenes.** This only allows the four Scene buttons, OFF button, IR receiver and the MASTER ▲ or ▼ to operate. All other buttons on the Control Unit are disabled.
 - bd Button Disable.** All buttons on the Control Unit are disabled. IR Receiver, and Wallstations are still functional. (Setup mode is still accessible by repeating Step 1.)
- 4. Exit setup mode.** Press and hold Scene 1 and OFF buttons until scene LEDs stop cycling.

STEP 3: Installing Wallstations/Controls

IMPORTANT WIRING NOTES!

Review Appendix A BEFORE wiring!

- Please refer to the Installation Instructions included with each Wallstation/Control before installing.
- Wallstations/Controls must be installed by a qualified electrician.
- Wallstations/Controls use Class 2 or PELV wiring methods as applicable in your locale.
 - **Using Class 2 wiring methods:** Wallstations/Controls must be connected in accordance with the 1996 National Electrical Code, Article 725-54(a), (1) Exception No. 3 or the Canadian 1994 CE Code Handbook, Rule 16-212, Subrule (4). Check with your local electrical inspector to comply with local codes and wiring practices.
 - **Using PELV wiring methods:** Wallstations/Controls that are connected to terminals 1—4 must always meet the requirements of DIN VDE 0100 Part 410 and IEC 60364-4-41 for PELV circuits. See "What is PELV?" in Appendix A.
- Wallstations/Controls must be mounted in a wallbox. Please refer to instruction sheet included with each Wallstation/Control to determine wallbox requirements.

STEP 4: Setting Up System Communications

This section shows how to set up communications between Control Units. For specific, step-by-step instructions about setting up communications for each type of *GRAFIK Eye* Wallstation, please refer to the instructions included with each Wallstation.

IMPORTANT!

First check Class 2/PELV wiring.

Before you set up communications, make sure your Class 2/PELV system interconnections are working.

1. Select Scene 1 (press the top button) on one of the Control Units.
2. Is Scene 1 selected on all other Control Units?
YES: Class 2/PELV wiring is OK. Proceed.
NO: Class 2/PELV wiring has a miswire. Check for loose connections, shorted or crossed links. Refer to Appendix A for details on Class 2/PELV wiring.

OR

GRAFIK Eye Control Unit has been addressed to other than A- (factory default). See below for more information on addressing Control Units.

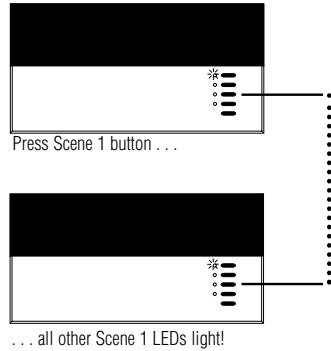

Assign Addresses to GRAFIK Eye Control Units

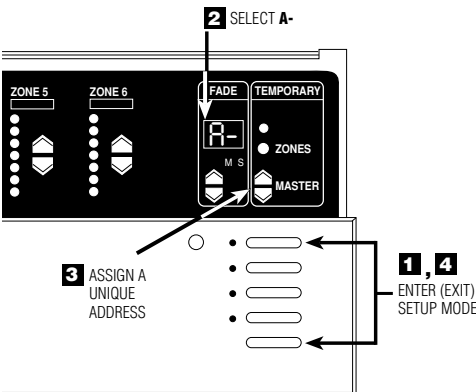

Assign each *GRAFIK Eye* Control Unit in your project a unique system address (A1 through A8). To assign an address:

1. **Enter setup mode.** Press and hold Scene 1 and OFF buttons about 3 seconds, until scene LEDs cycle.
2. **Select A-** (the address display). Press FADE ▲ once, **A-** appears in the FADE window.
3. **Assign a unique address.** Press MASTER ▲ once, the next "free" (unassigned) address automatically appears in the FADE window. This will be the Control Unit's address. (If you are working on the first Control Unit in the project, **A1** will appear.)
4. **Exit setup mode.** Press and hold Scene 1 and OFF buttons about 3 seconds, until the LEDs stop cycling.
5. **Repeat** steps 1 through 4 for each *GRAFIK Eye* Control Unit.

Set up Communication between 2 or more Control Units

This page explains how to use 2-way communications to set up lighting effects for more than six zones (the maximum number of zones any *one* 3000 Series Control Unit can operate). When you set up two-way communications between Control Units, selecting a scene at any one of these Units automatically activates the same scene in the others. By linking eight 6-Zone Control Units, you can create scenes that control the intensity of up to 48 zones. This “large-zone” capability is ideal for large spaces with dramatic lighting that changes frequently (e.g., churches).

For example: 16-Zone Control

Selecting a scene on A1 . . .

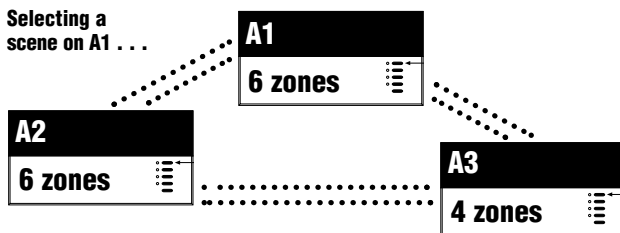

. . . Activates the same scene on A2 and A3.

Linked by two-way communications, these Control Units act like a 16-Zone Control Unit. Note that you must set up communications *both* ways among *all* Control Units:

- A1 “talks” to A2 and A3 — and “listens” to them as well.
- A2 “talks” and “listens” to A1 and A3.
- A3 “talks” and “listens” to A1 and A2.

Make sure you have addressed the Control Units (as described on page 9) before setting up two-way communications.

Set up communications in one direction . . .

1. **Put A1 in setup mode.** Press and hold Scene 1 and OFF buttons for about 3 seconds, until LEDs cycle.



2. **Identify the Control Units to “listen”** (A2 and up to 6 others). Press and hold the Scene 1 button for about 3 seconds until LEDs flash in unison, showing that these Control Unit(s) are “listening” to A1. (To make a “listening” Control Unit not listen to A1: Put A1 in setup mode, then press the “listening” Control Unit’s OFF button until the LEDs stop flashing.)



3. **Take A1 out of setup mode.** Press and hold Scene 1 and OFF buttons for about 3 seconds, until LEDs on A1, and all other linked Control Unit(s), stop cycling. You have set up communications in one direction between A1 and all “listening” Control Units.

4. To complete the two-way communication, reverse the process described above: Put A2 in setup mode; then make A1 (and any other Control Units) “listen”; then take A2 out of setup mode.

. . . then the other.

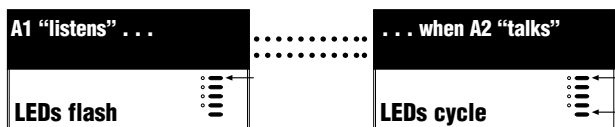

Appendix A: More about Class 2/PELV Wiring

This appendix explains the Class 2/PELV wiring used to carry communications between *GRAFIK Eye* Control Units and Wallstations.

Lutron requires that you connect (daisy-chain) all *GRAFIK Eye* 3000 Series Control Units and Wallstations with two twisted pair for operation. If shielded wire is used, the drain wires must be connected to each other or to Terminal D, if present. Drain wires should not be connected to Earth/Ground.

- One pair is for the low-voltage power wiring that enables each *GRAFIK Eye* Control Unit to supply power to up to three Wallstations. Connect this twisted pair to terminals 1 (COMMON) and 2 (12VDC). Terminate the 12VDC power to ensure that each Control Unit powers **no more than three Wallstations**.
- The second pair is for a data link (up to 2000 ft. or 450 m long) that enables Wallstations to communicate with *GRAFIK Eye* Control Units. Connect this twisted pair to terminals 3 (MUX) and 4 (MUX) of every Control Unit and Wallstation.

Each twisted pair in the Class 2/PELV wiring link should consist of two #18 AWG (1.0 mm²) stranded conductors.

- **Lutron offers a one-cable, low-voltage solution: P/N GRX-CBL-346S (non-plenum), or GRX-PCBL-346S (plenum).**

Recommended unshielded cables:

- For non-plenum installations, use (2) Belden 9470, (1) Belden 9156, or (2) Liberty 181P/2C-EX-GRN, or equivalent.
- For plenum installations, use (2) Belden 82740, or equivalent.

Wallstation circuits are classified as Class 2 circuits (U.S.A) and PELV circuits (IEC). Unless otherwise specified, the voltages do not exceed 24VAC or 15VDC. As Class 2 circuits, they comply with the requirements of NFPA 70®, National Electrical Code® (NEC®). As PELV circuits, they comply with the requirements of IEC 60364-4-41, VDE 0100 Part 410, BS7671:1992 and other equivalent standards. When installing and wiring to these Wallstations, follow all applicable national and/or local wiring regulations. External circuits connected to input, output, RS232, DMX512, and other communication terminals of Wallstations, must be supplied from a Listed Class 2 source or comply with the requirements for PELV circuits as applicable in your country.

The *GRAFIK Eye* 3000 Series Control Unit Class 2/PELV circuit is 12VDC.

What is PELV?

In countries that abide by the IEC regulations, PELV is commonly referred to as Protective Extra-Low Voltage. A PELV circuit is an earthed circuit in which the voltage cannot exceed 50VAC or 120V ripple-free DC. The power source must be supplied by a safety isolating transformer or equivalent.

IMPORTANT WIRING NOTE!

Proper separation is required between the Line Voltage/Mains cables and PELV cables. Use certified cable for all Line Voltage/Mains cables and PELV cables. Cable bearing HAR or national certification marks are acceptable, provided it covers all applicable wiring regulations for fixed installations. See Important Wiring Note on Page 3.

A Control Unit with up to three Wallstations

See Important Wiring Notes on Page 12. Each Control Unit can power up to three Wallstations. If you need to power more than three Wallstations from one Control Unit, install an external 12VDC power supply (Lutron P/N GRX-12VDC).

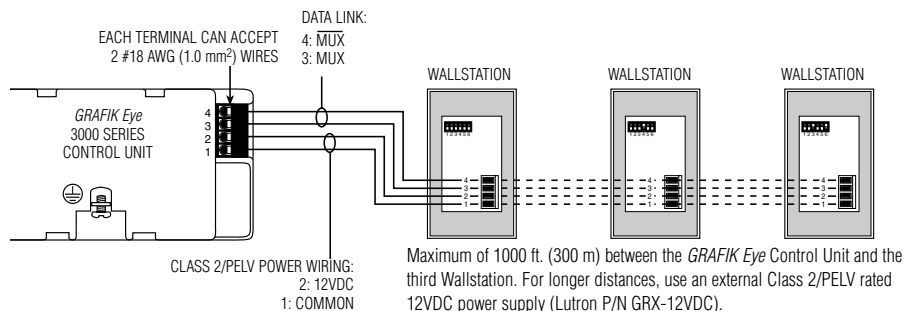

IMPORTANT WIRING NOTES!

1. Daisy-chain the terminal 1, terminal 2, terminal 3, and terminal 4 connections to all Control Units and Wallstations. The Control Unit has *its own* power supply.
2. Each Control Unit can power up to three Wallstations. If you need to power more than three Wallstations from one Control Unit, install an external 12VDC power supply as described later in this section.
3. Lutron recommends that all connections be made in the unit wallbox. Remote connection must be in a switchbox or junction box with a maximum wire length of 8 ft. (2.5m) from the link to the connected unit.

Note: Do not allow Class 2/PELV wires to contact line/mains wires. Refer to Class 2/PELV wiring on Page 4.

Up to 8 Control Units and 16 Wallstations

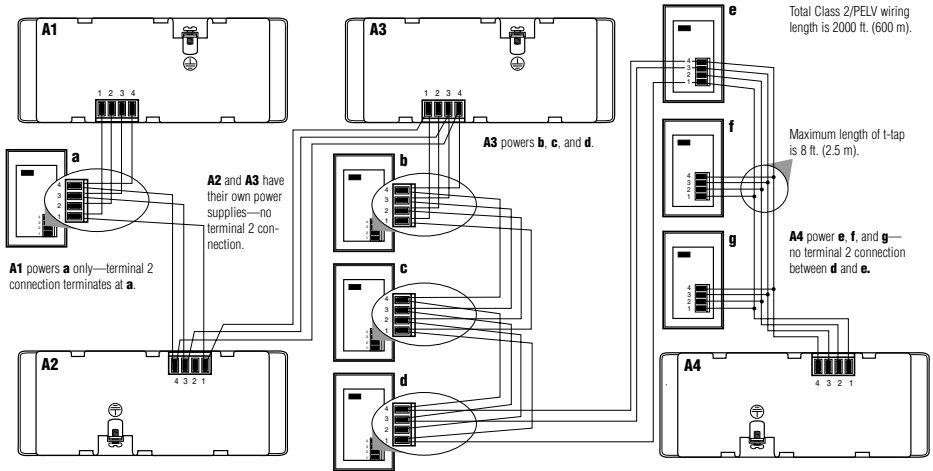

IMPORTANT WIRING NOTES!

1. Daisy-chain the terminal 1, terminal 3, and terminal 4 connections to all Control Units and Wallstations. Each Control Unit has *its own* power supply. Terminate the terminal 2 connection (12VDC power) so that:
 - Each Control Unit supplies power to a *maximum* of three Wallstations.
 - Each Wallstation receives power from *only one* Control Unit.
2. Lutron recommends that all connections be made in the Control Unit's wallbox. Remote connection must be in a switchbox or junction box with a maximum wire length of 8 ft. (2.5 m) from the link to the connected unit.

Note: Do not allow Class 2/PELV wires to contact line/mains wires. Refer to Class 2/PELV wiring on Page 4.

Installing an External Power Supply

Install an external Class 2/PELV rated 12VDC power supply as shown on Page 13. This power must be Class 2/PELV rated and be a regulated supply rated for at least 50 mA per Wallstation on the link. It can supply power to up to 16 Wallstations, enabling you to use up to 16 Wallstations with one Control Unit.

Use an external power supply if you need to power more than 3 Wallstations from a single Control Unit or if your wire lengths exceed maximums. Power supplies do not boost data line signals. The distance limitation for the data line is 2000 ft. (450 m).

Make sure you review the manufacturer's instructions before installing.

Lutron offers a 12VDC transformer for 120V applications. Please ask for P/N GRX-12VDC.

IMPORTANT WIRING NOTES!

1. Connect the +12VDC wire from the power supply to the terminal 2 connection on all Wallstations. Do not connect this wire to any Control Units on the link. Be sure that the terminal 1 connection is made to all Wallstations and Control Units.
2. Lutron recommends these maximum distances from the external 12VDC power supply to the sixteenth Wallstation:
 - #18 AWG (1.0 mm²) wire: 300 ft. (90 m).
 - #12 AWG (2.5 mm²) wire: 1000 ft. (300 m).

Note that the allowable maximum distance depends on the number of Wallstations in the system. Please see Application Note W14 or consult Lutron Technical Support for more detailed information.

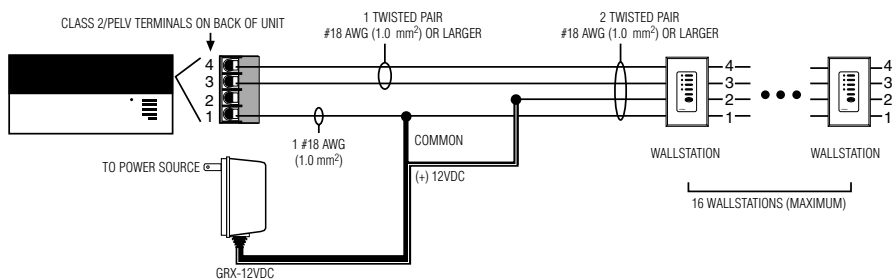

Appendix B: Special Mounting Considerations

Wallbox Mounting

Spacing of the *GRAFIK Eye 3000 Series Control Unit*

When mounting multiple *GRAFIK Eye 3000 Series Control Units* near each other, the following spacing and ventilation guidelines are required for proper operation.

- All *GRAFIK Eye 3000 Series Control Units* **MUST** be mounted in a standard U.S. Wallbox. These are available from Lutron.
 - For two-zone Control Units, Power Boosters, Fluorescent Interfaces, and Electronic Low-Voltage Interfaces, use two P/N 241-519 single-gang wallboxes.
 - For three-zone Control Units, use three P/N 241-519 single-gang wallboxes.
 - For four-zone (or larger) Control Units, use one P/N 241-400 four-gang wallbox.

Note: All GRX-CE Control Units mount in one P/N 241-400 four-gang wallbox.

- All *GRAFIK Eye 3000 Series Control Units*, Power Boosters, Fluorescent Interfaces, and Electronic Low-Voltage Interfaces **MUST** have 4 1/2 in. (11 cm) of space above and below the faceplate to dissipate the heat caused by normal operation.

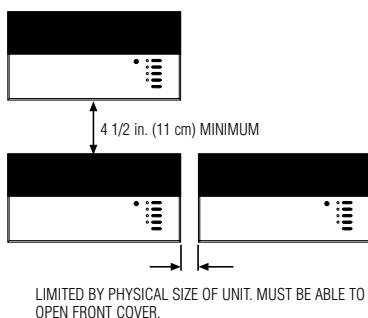

Panel Mounting

- The enclosure must be in accordance with all local and national electrical codes.
- Lutron does not recommend using a door to enclose the front of a panel, since this restricts airflow to the *GRAFIK Eye 3000 Series Control Units* and Interface Devices.
- If mounting multiple *GRAFIK Eye 3000 Series Control Units* or Interface Devices in an enclosure:
 - Ambient temperature within an enclosure **MUST remain between 32°—104° F (0°—40° C)**.
 - If not mounting in a metal enclosure, all units **MUST** be mounted in a wallbox. Refer to Wallbox Mounting above.
- To improve heat dissipation of Interface Units, (i.e., NGRX-PB, GRX-ELVI, etc.), remove the faceplate from the unit.

IMPORTANT NOTE:

GRAFIK Eye 3000 Series Control Units and Interface Devices, such as NGRX-PB, dissipate heat when operating.

Obstructing these units can cause malfunction to both the Control Unit and the Interface Device if ambient temperature does not remain between 32°—104° F (0°—40° C).

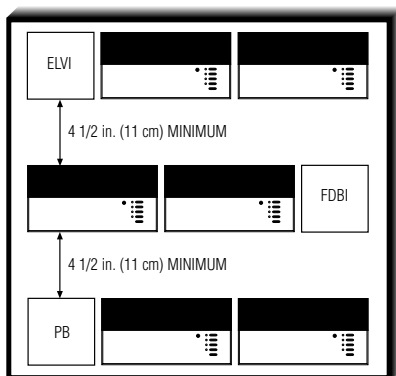

Appendix C: Troubleshooting

If the *GRAFIK Eye* lighting controls in your project aren't working as specified . . .

- Review carefully the *GRAFIK Eye* submittal documentation prepared for your project — especially the project's One-Line Diagram, which gives an overview of the wiring and shows how all *GRAFIK Eye* equipment connects. The *GRAFIK Eye Designer*™ software, which produces such one-line diagrams, is available from Lutron.
- If necessary, call Lutron.

Problem	Cause	Remedy
Unit does not turn lights on	Breaker/MCB is off Long fade time Low zone settings Miswire System short circuit System overload	Switch breaker/MCB on. Set FADE time to 0 seconds. Use zone ▲ for each scene. Check wiring (refer to wiring details). Find and correct shorts in fixtures and/or wallbox. Make sure lighting loads don't exceed Unit's maximum rated load.
Unit does not control load ZONE control does not work	Miswire Disconnected wires Burned-out lamps	Check wiring (refer to wiring details). Connect zone wires to loads (refer to wiring details). Replace bad lamps.
1 or more zones are "full-on" when any scene is on and zone intensity is not adjustable (and zone is not a non-dim)	Miswire Shorted triac	Make sure loads are connected to the right zones (refer to wiring details). Replace Control Unit.
A ZONE control affects more than one zone	Miswire	Check wiring (refer to wiring detail).
Wallstation does not function properly	Miswire or loose connection Wallstation not set up properly	Check and tighten loose connections at Class 2/PELV terminals on Unit and Wallstations (refer to Appendix A). Confirm programming.
Faceplate is warm	Normal	Solid-state controls dissipate about 2% of the connected load as heat.
Unit does not allow scene changes or zone adjustments	Unit may be set to an optional Save Option.	Refer to Page 8 for Save Options.

WORLD HEADQUARTERS

Lutron Electronics Co. Inc.
7200 Suter Road
Coopersburg, PA 18036-1299 U.S.A.
TOLL FREE: (800) 523-9466 (U.S.A., Canada, Caribbean)
Tel: (610) 282-3800; International 1 610 282-3800
Fax: (610) 282-3090; International 1 610 282-3090

EUROPEAN HEADQUARTERS

Lutron EA Ltd.
Lutron House
6 Sovereign Close
Wapping
London, E1W 3JF, United Kingdom
FREEPHONE: 0800-282107 (U.K.)
Tel: (207) 702-0657; International 44 207 702-0657
Fax: (207) 480-6899; International 44 207 480-6899

ASIAN HEADQUARTERS

Lutron Asuka Co., Ltd.
2nd Floor, Kowa Shibakoen Bldg.
1-1-1111, Shibakoen
Minato-ku, Tokyo
105-0011 Japan
TOLL FREE: (0120) 083417 (Japan)
Tel: (03) 5405-7333; International 81-3-5405-7333
Fax: (03) 5405-7496; International 81-3-5405-7496

Lutron Electronics, Co., Inc., reserves the right to make improvements or changes in its products without prior notice. Although every attempt is made to ensure that this information is accurate and up to date, please check with Lutron to confirm product availability, latest specifications and suitability for your application.