



# SC100

## SATELLITE CONTROLLER



**MODELS:**

**3515**

**3515A**

**SERVICE  
MANUAL**



## TABLE OF CONTENTS

Specifications.....	1	Assembly & Installation .....	5
Electrical .....	1	Controller.....	12
Weight.....	1	POP Display Window .....	13
Dimensions .....	1	Door Lock & Keys.....	13
Factory Options.....	1	Order Information .....	14
Introduction .....	1	Returns.....	15
Component Identification.....	2	Limitation of Liability .....	15
Unpacking.....	3		
Pre-Installation Requirements .....	3		
Grounding (Earthing) & Electrical .....	4		

Please find the identification plate located on the backside of the cabinet, and record the model and serial numbers on the space below.

MODEL NUMBER: \_\_\_\_\_

SERIAL NUMBER: \_\_\_\_\_

The model and serial numbers will aid us in providing you with correct and efficient service or parts information for your machine should that need arise.



# SPECIFICATIONS

Model 3515, 3515A

## ELECTRICAL

- 115V, 1.2 Amps, 60 Hz
- (220V Option)

## WEIGHT

- 175 Pounds [79.4 kg]

## DIMENSIONS

- Cabinet Width: 11-1/8" [28.3 cm]
- Door Width: 12" [30.5 cm]
- Depth: 33-3/8" [84.8 cm]
- Height: 72" [183 cm]

## FACTORY OPTIONS

- POP Option
- Language Option
- Coin Mech Option
- Validator Option

# INTRODUCTION

This manual contains instructions, service and installation guidelines for the SC100 Satellite Controller.

All programming of vend functions, pricing and features are done at the controller. Changes can be made without any additional accessories or remote parts.

Selections can be priced individually from \$.05 to \$99.95 in five cent increments (U.S. currency). When adapted to accept international or foreign, the maximum vend price will be 255 times the smallest denomination of coin being accepted.

Cash accountability records Total Cash transactions and Total Vend cycles performed by the vending machine. Information for individual selections, complete rows or total machine can be compiled and used for inventory and ordering records.

Electrical malfunctions are recorded and displayed when the machine is placed in Service Mode. Each SC100 Satellite Controller has the capability of supporting a "satellite" vending machine, such as a Can Vending Machine, Cold/Frozen Satellite Food Vending Machine, or combi

machine. For details on the satellite vending machine, refer to the service manual pertaining to the specific vending machine.

If you have any questions pertaining to the information in the manual, replacement parts or the operation of the vending machine, then you should contact your local distributor or:

**VendNet™**  
165 North 10<sup>th</sup> Street  
Waukee, Iowa 50263  
United States of America

Phone: (515) 274-3641  
Parts Fax: (515) 987-4447  
Sales Fax: (515) 274-0390  
Email: [vendnet@vendnetusa.com](mailto:vendnet@vendnetusa.com)  
Website: <http://www.vendnetusa.com>

This manual should be read thoroughly in order to become familiar with the functions and features of the SC100. The initial set-up of a vending machine is a very important step of insuring that the equipment operates in a trouble-free manner. Following the instructions at the initial installation of the machine will avoid service problems and minimize set-up time.

### COMPONENT IDENTIFICATION

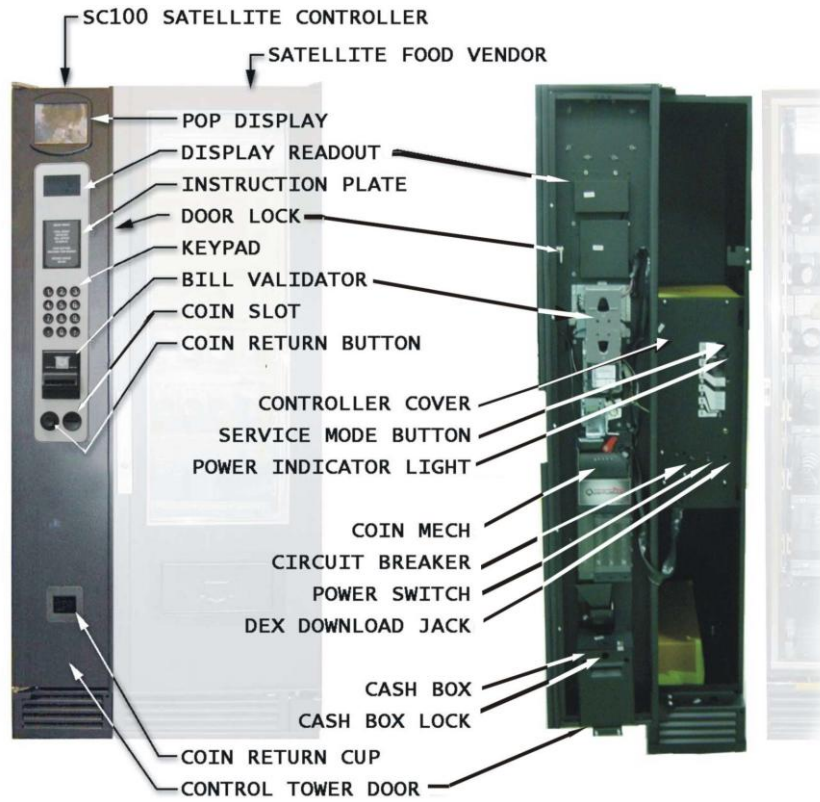

## UNPACKING

This machine was thoroughly inspected before leaving the factory and the delivering carrier has accepted this vending machine as their responsibility. **Note any damage or irregularities at the time of delivery and report them to the carrier.** Request a written inspection report from the claims inspector to file any claim for damage. File the claim with the carrier (not the manufacturer) within 15 days after receipt of the machine.

Cut the plastic banding around the SC100. Remove the screws from the front board of the shipping skid. Slide the SC100 forward to remove from the skid.

Carefully remove the outside packing material so as not to damage the finish or exterior of the machine. Inspect the machine for concealed shipping damage. Report any damage hidden by shipping material directly to the delivering carrier on a hidden damage report.

Record the model number and serial number of the vending machine for your records. These numbers can be found on the Serial Plate on the rear of the cabinet and/or inside the SC100. Refer to these numbers on all correspondence and inquiries pertaining to SC100.

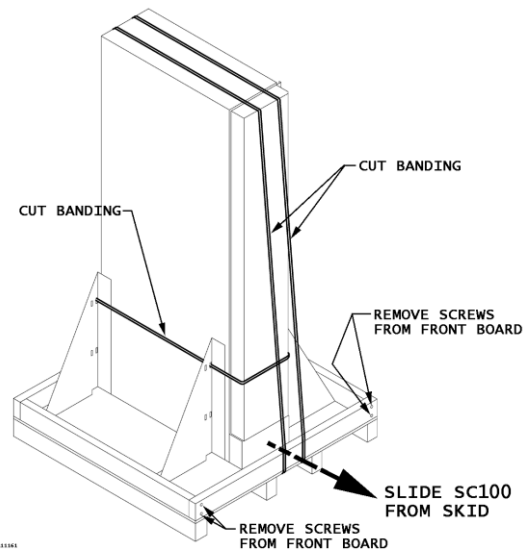

## PRE-INSTALLATION REQUIREMENTS

The SC100 and the Satellite Food Vending Machine in its place of operation should be no further than nine feet (9 ft.) from the power outlet or receptacle. The doors must open fully without interference. Most satellite units must have at least six inches (6" in.) of space between the back of the vending machine and any wall or obstruction for proper air circulation. All leg levelers must touch the floor. The vending machine must be level for proper operation and acceptance of coins through the coin mechanism.

Retrieve the keys to the SC100 from the coin return cup. Open the outer door and remove all internal packing material.

Consult local, state and federal codes and regulations before installation of the vending machine.

## GROUNDING (EARTHING) & ELECTRICAL

Before connecting the vending machine, the integrity of the main electrical supply must be checked for correct polarity, presence of ground (earth) and correct voltage. These checks should be repeated at six (6) month intervals with the routine safety electrical testing of the vending machine itself.

To verify that the receptacle is properly grounded and polarized, insert one probe of a Multi-Meter (set to check AC line voltage) or a test light in the ground terminal (hole) and the other probe into the hot terminal of the outlet.

If the receptacle is not properly grounded or polarized, you should contact a licensed electrician to correctly polarize and/or ground the receptacle to ensure safe operation.

A noise suppressor (line filter) has been installed in this machine to compensate for any mains signal noise that could interfere with the normal operation of the controller.

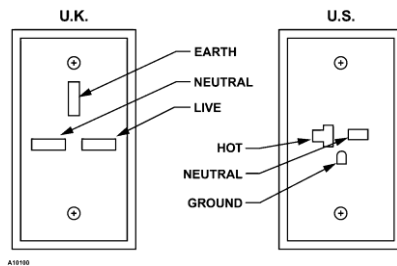

Figure 1. 230 Volt Outlets

For proper operation of any equipment utilizing electronically controlled components, the equipment should be placed on an isolated or dedicated noise-free circuit, properly polarized and grounded.

Refer to **Specifications** on page 1 to determine circuit amperage and protection.

Shown in **Figure 2** are two properly grounded and polarized wall outlets. **Figure 1** shows two 230-volt wall outlets. **Figure 1** shows a 115-volt, two-wire outlet with a three-plug adapter in place.

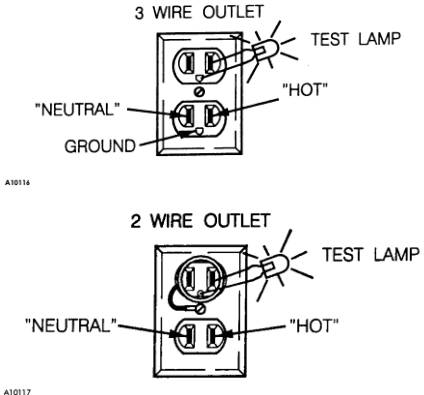

Figure 2. 115 Volt Outlets



# ASSEMBLY & INSTALLATION

## SAFETY & WARNING

Always disconnect power before servicing.

- 1 TOOLS NEEDED**
- Phillips Screw Driver

**2 DO NOT** CONNECT POWER TO THE SC100.  
**DO NOT** CONNECT POWER TO THE SATELLITE FOOD VENDING MACHINE.

**3 REMOVE NEW DOOR TRIM & SAFETY BRACKET FROM INSIDE THE SC100 IDENTIFY CONTENTS OF SMALL PARTS PACKAGE.**

WING SCREW (5)  
WING NUT (5)  
CABLE CLAMP  
CARRIAGE BOLT (5)  
LARGE PHILLIPS HEAD SCREW (2)  
SMALL PHILLIPS HEAD SCREW (3)

TORX KEY WRENCH  
POWER CORD  
LIFTER  
DOOR TRIM  
SAFETY BRACKET

NOT TO SCALE

A13.148

**4 REMOVE ANTI-CHEAT PANEL FROM FOOD VENDING MACHINE (ANTI-CHEAT PANEL WILL BE RE-USED ON STEP 14).**

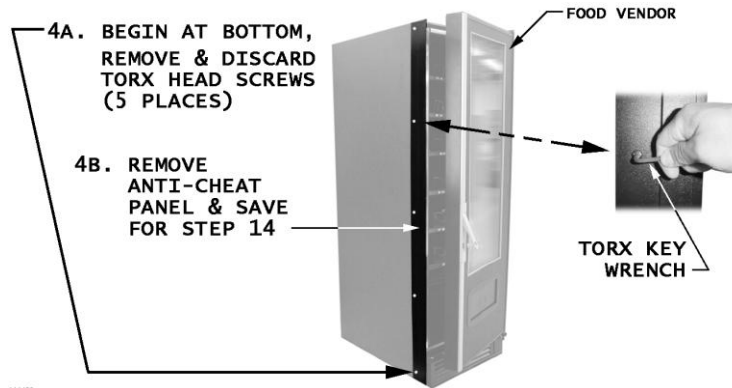

**5 REMOVE DOOR TRIM FROM FOOD VENDING MACHINE (DOOR TRIM IS NO LONGER NEEDED).**

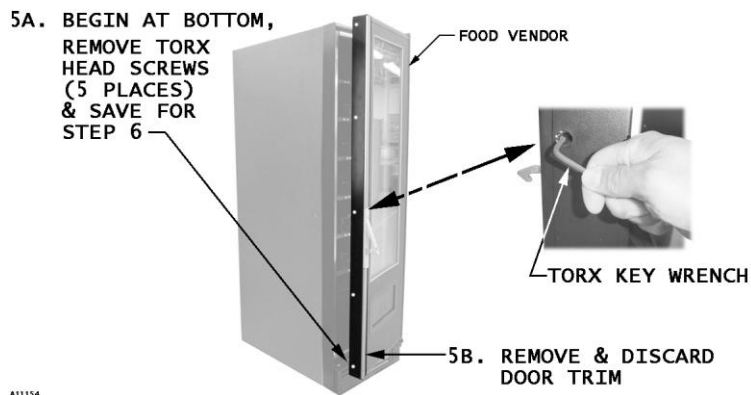

**6** INSTALL NEW DOOR TRIM ON FOOD VENDING MACHINE DOOR (NEW DOOR TRIM SHIPPED INSIDE SC100).

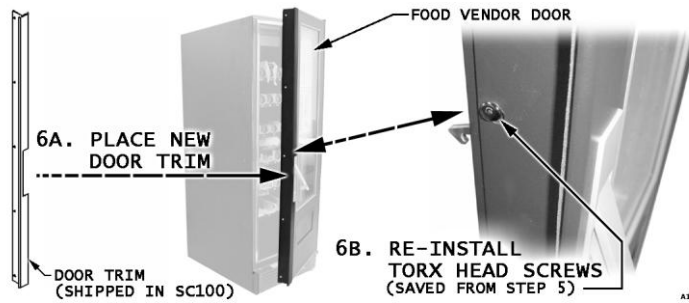

**7** POSITION SC100 TO FOOD VENDING MACHINE. INSTALL SAFETY BRACKET.

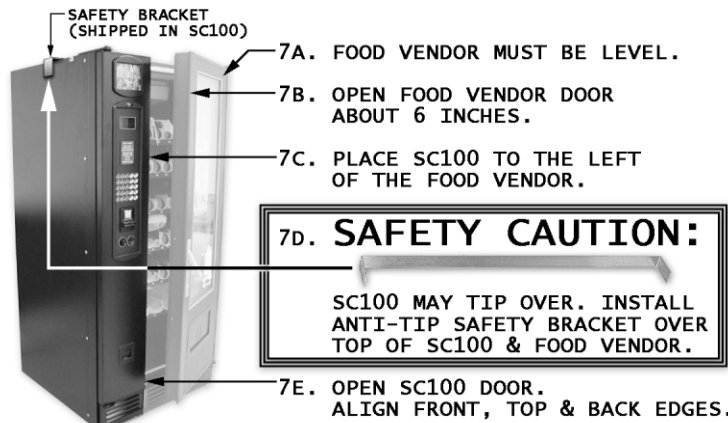

**8** ADJUST SC100 FRONT & REAR LEG LEVELERS.

**SC100 MUST BE LEVEL AT THE TOP,  
STABLE AND ALIGNED WITH FOOD VENDOR**

- 8A. SLIDE LIFTER UNDER SC100, THEN STEP ON LIFTER TO LIFT
- 8B. ADJUST LEG LEVELERS
- 8C. GO TO REAR OF SC100, REPEAT STEPS 8A & 8B TO ADJUST REAR LEG LEVELERS

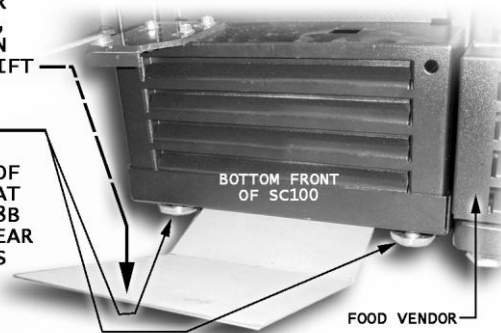

A11147

**9** ATTACH BOTH TOP & BOTTOM BRACKETS (LOCATED AT REAR OF SC100).

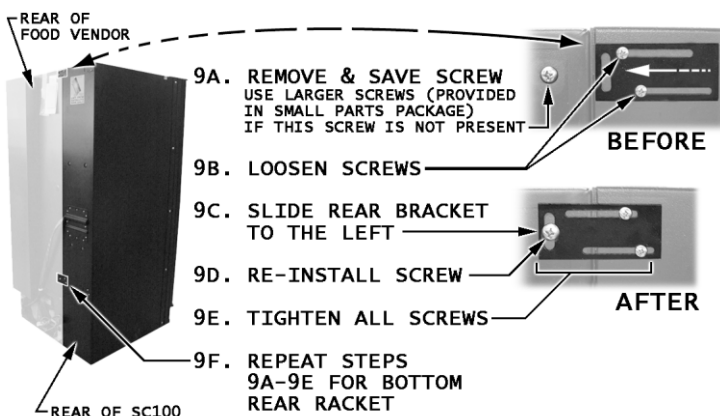

A11150

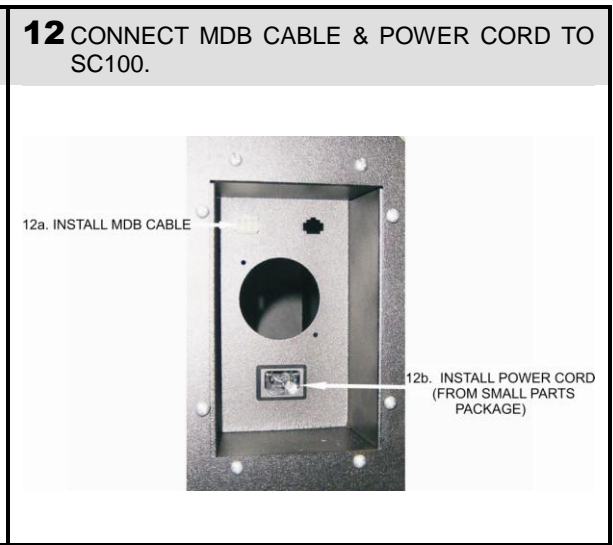
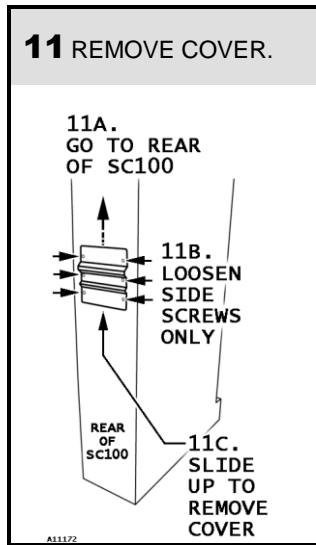
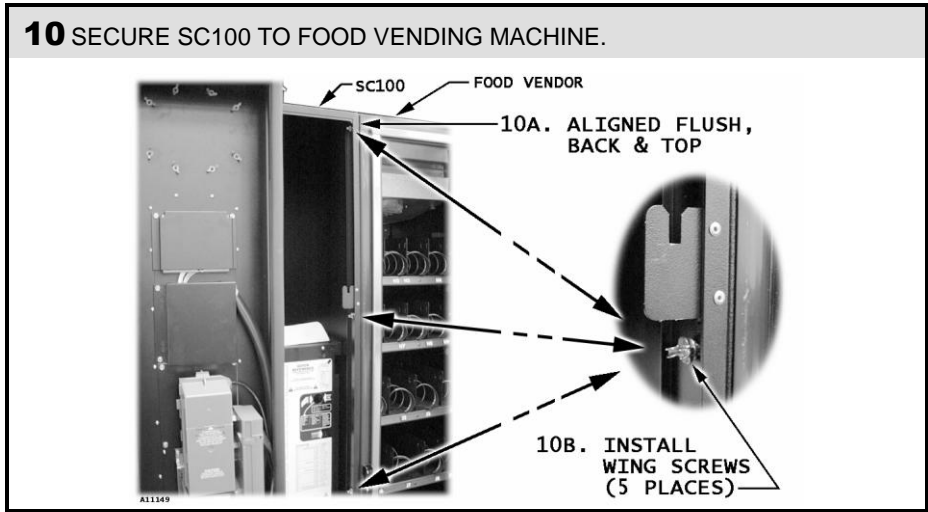

**13** CONNECT MDB CABLE TO FOOD VENDING MACHINE & INSTALL CLAMP.  
RE-INSTALL SC100 COVER.

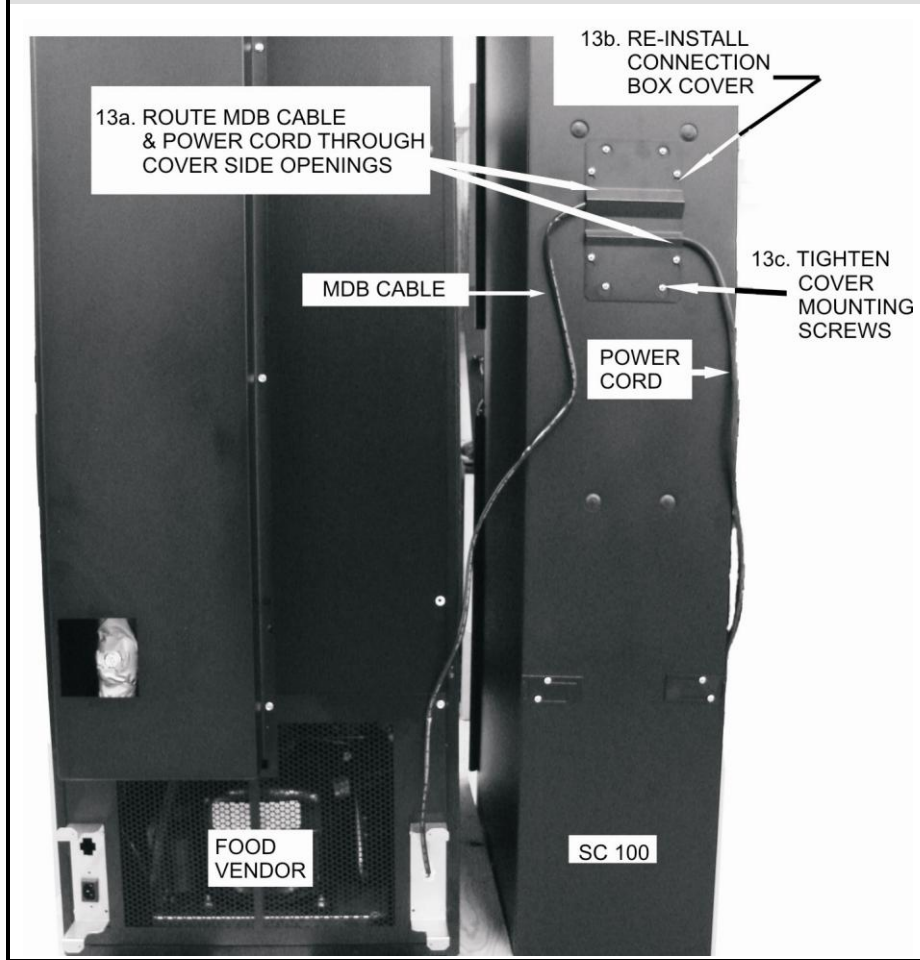

**14** INSTALL ANTI-CHEAT PANEL TO LEFT SIDE OF SC100.

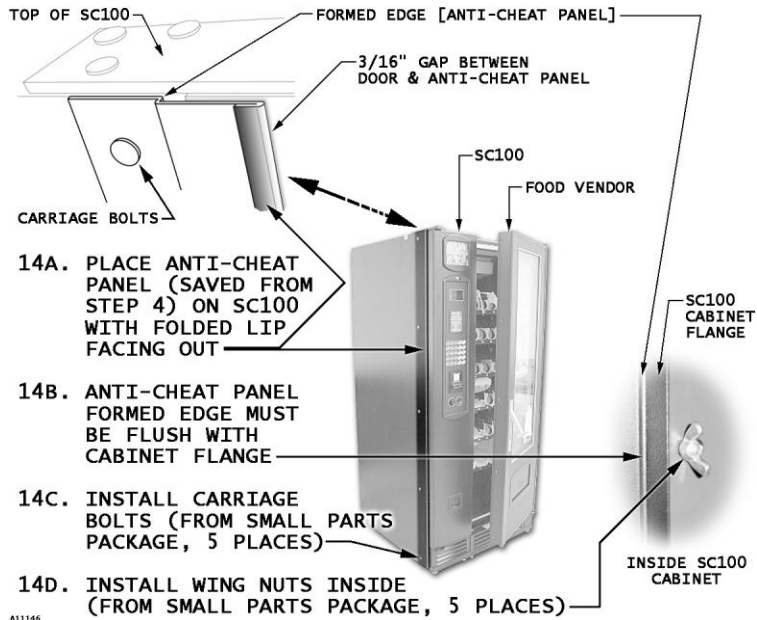

**15** CLOSE DOORS.



**16** INSTALL CLAMP AND COVER.

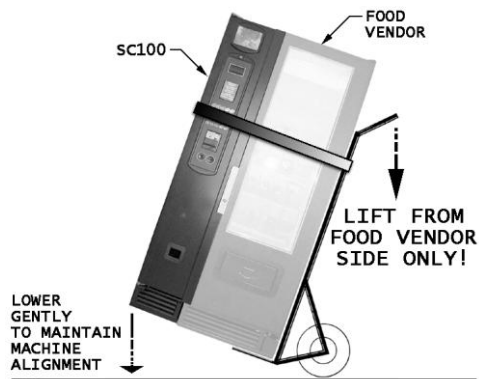

**17** CONNECT POWER TO SC100 & FOOD VENDING MACHINE.  
TURN ON POWER TO BOTH.

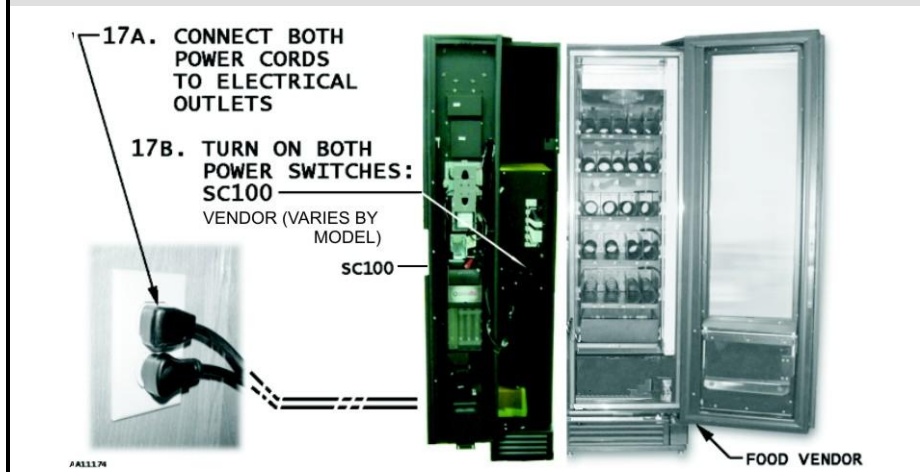

## CONTROLLER

The Controller is located behind the controller cover. The Service Mode button is located on the right side of the controller and can be accessed through a hole in the cover.



Figure 3. Service Mode Button



## POP DISPLAY WINDOW

If necessary, the POP (point of purchase) Display Window graphic can be replaced. To replace the graphic, open the SC100 door and find the wing nuts located behind the Display Window. Remove the wing nuts. Remove the Display Window Bezel and replace the graphic. Re-install the Display Window Bezel.



Figure 4. Replacing Display Window Graphic

## DOOR LOCK & KEYS

A door lock is provided to allow locking of the SC100 door separate from the satellite. This allows some security of the money in the SC100.

The door lock keys are normally shipped inside the coin cup. Turn the key clockwise to lock or counter-clockwise to unlock.

### IMPORTANT

The SC100 door key must be removed before closing the satellite food vending machine door.



Figure 5. Door Lock

## **ORDER INFORMATION**

You may order parts from your distributor or from VendNet™. If you have any questions when placing your order, please call and we will be happy to assist you. Please provide the following information when placing your order:

- Quantity required
- Part number
- Description of part
- Vending machine model number
- Vending machine serial number
- Shipping and billing address
- Preferred method of shipment
- Customer account number

**Note:**

When "right" and "left" are used with a part name, it is taken to mean that the person is facing the machine with the door closed.

### **MINIMUM ORDER**

You may wish to inquire on prices of parts and minimum order amount at the time of your order. If you order less than the minimum, please check our catalog for other parts you may require to bring your order up to the minimum amount.

VendNet™ reserves the right to change these requirements without notice.

### **PAYMENT**

Several payment options are available:

- MASTER CARD
- DISCOVER
- VISA
- C.O.D.
- OPEN ACCOUNT (with approved credit)

### **TO ORDER BY MAIL**

Order forms are available upon request or you may use your own purchase order form. You may mail your order for replacement parts by providing the necessary information as requested above to:

VendNet™  
165 North 10th Street  
Waukeg, IA 50263-0488  
USA

### **TO ORDER BY FAX**

You may FAX your order for replacement parts by providing the necessary information as requested above to VendNet™:

**1-515-987-4447**

### **TO ORDER BY PHONE**

You may call in your order for replacement part by providing the necessary information as requested above to VendNet™ Parts Department.

USA 1-888-259-9965

Canada 1-800-858-4730

Other 1-515-274-3641

### **TO ORDER ON THE WEB**

You may go online and place an order through the internet:

<http://www.vendnetusa.com>

<http://www.vendnet.ws>

### **RETURNS**

A restocking charge of 20% will apply to merchandise accepted by VendNet™ for return, except items processed as warranty. A Return Form clearly stating the reason for return must accompany all items returned. Return Forms are available upon request from VendNet™. Returns are to be shipped freight prepaid to:

VendNet™

165 North 10th Street

Waukegan, IA 50263-0488

### **LIMITATION OF LIABILITY**

VendNet™ shall not be liable for any injury, loss or damage, whether direct, incidental or consequential arising out of the use of or the inability to use any part, parts or products sold by VendNet™. The remedies of the buyer set forth herein are exclusive, and the liability of VendNet™. With respect to any contract or sale or anything done in connection herewith, whether in contract, in tort, under any warranty, or otherwise, shall not, except as expressly provided herein, exceed the price of the part, parts or products on which such liability is based. Any statements or representations about the parts or product, other than those contained herein, do not constitute warranties and shall not be relied on by the buyer and shall have no force of effect unless contained in a written agreement signed by officers of VendNet™.

### **QUESTIONS**

If you have any questions:

- Check our website at [www.vendnetusa.com](http://www.vendnetusa.com) or [www.vendnet.ws](http://www.vendnet.ws)
- Send an email to [vendnet@vendnetusa.com](mailto:vendnet@vendnetusa.com)
- Or call VendNet™ at (800) 833-4411 and ask for the Parts Department.

**NOTES:**

*The contents of this publication are presented for informational purposes only, and while every effort has been made to ensure their accuracy, they are not to be construed as warranties or guarantees, express or implied, regarding the products or services described herein or their use or applicability. We reserve the right to modify or improve the designs or specifications of such products at any time without notice.*



**VendNet™**  
165 North 10th Street  
Waukee, Iowa 50263-0488  
United States of America



	USA & Canada	International
Service	<b>(800) 833-4411</b>	<b>(515) 274-3641</b>
Parts	<b>(888) 259-9965</b>	
Email	<b>vendnet@vendnetusa.com</b>	
Web Site	<b>www.vendnetusa.com</b>	